

17



MOTACC[®]

SPEED BRAKES
Made in Switzerland

STAHLFLEXBREMSLEITUNGEN



Bremsleitungen

Brake lines

Stahlflexbremsleitungen	Steel braided brake lines	02
Motorrad Bremsleitungskits	Motorbike brake line kits	03
Einzelbremsleitungen nach Mass	Single brake lines made to order	04
Auto Bremsleitungen	Car brake lines	05
Vario System (Motorrad und Auto)	Vario system (motorbike and car)	06

NEW

Flexibles Schraubsystem	Flexible screw system	09
--------------------------------	------------------------------	-----------

Speed Bleeder ®	Speed Bleeder ®	12
Ringfittige (Vario und festverpresst)	Ring fittings (Vario and crimped)	13
Gewinde (Vario und festverpresst)	Thread (Vario and crimped)	15
Hohlschrauben	Banjo bolts	18
Kupplungen und Verteiler	Couplings and manifolds	21
Stäubli Schnellkupplungen	Stäubli quick connectors	24
Sonstiges Zubehör	Accessories	25
Sonderteile	Special parts	27
Technische Zeichnungen	Technical drawings	29

Edelstahl
Stainless steel

Ringfittige (Vario und festverpresst)	Ring fittings (Vario and crimped)	44
Gewinde (Vario und festverpresst)	Thread (Vario and crimped)	45
Technische Zeichnungen	Technical drawings	48

Firmengeschichte	Company history	57
Variokofferset mit Halterung	Vario kit with holder	59
Bördelwerkzeugset	Flaring tool kit	60

mit transparentem PVC Mantel
with clear PVC cover



mit farbigem PVC Mantel
with colored PVC cover



ohne PVC Mantel
without PVC cover



Anschlüsse gefertigt aus speziellem Aluminium oder Edelstahl mit optimaler Festigkeit.
Fertigung im hauseigenen Maschinenpark mit hochpräzisen CNC-Drehmaschinen.
Eloxalfarben in höchster Qualität von weltweit führendem Hersteller aus der Schweiz. Mit bester UV- und Witterungsbeständigkeit für langanhaltenden Farbglanz.

Fittings made of special aluminium or stainless steel for best endurance, made in-house by high precision CNC machines.
Anodized colors in highest quality by the worldwide leading company in Switzerland offer best light and weather resistance.

Durch die Herstellung des Anschlusses mit speziellem Dichtsystem ist es möglich, den Anschluß im verpressten Zustand zu verdrehen um damit die Leitung drallfrei verlegen zu können.

Due to special sealing system all fittings are adjustable for mounting without torsion/tension and free of any kinks.

Anschlußverpressung mit rostfreier (INOX)Presshülse. Hülse speziell gefertigt für höchste Sicherheit bezüglich Zug und Druck. Das Mikropresssystem garantiert dauerhaft gleichbleibende Verpressungen mit höchster Sicherheit und 100% Dichtheit.

Stainless steel crimping sleeve with microcrimping system for maximum security.

Alle Leitungen mit TÜV oder ABE!
Zugelassen auch für ABS Bremssysteme!
Produktionsdatum nachvollziehbar über Kennzeichnung auf Knickschutz.

All lines are homologated by German TÜV and compliant with US standard FMVSS 106 DOT.
Date of production documented by identification mark. Approved for ABS systems!

Leitung besteht aus einer PTFE Innenseele mit hochflexiblem Stahlflexmantel aus Inox-Stahl
UV resistenter PVC Mantel (keine Verfärbungen!) in verschiedenen Farben.

Brake line consists of PTFE inner hose with highly flexible INOX meshwork and a UV resistant (no discoloration!) cover available in different colors.

Die Firma Speedbrakes produziert seit 1995 in der Schweiz Bremsleitungskomponenten in höchster Qualität und gehört zu den führenden Herstellern.

Speedbrakes Bremsleitungen zeichnen mit **schlankem Design** aus und sind für **alle hydraulischen Bremsanlagen** lieferbar. Durch die hauseigene Produktion ist Speedbrakes in der Lage individuell auf Kundenwünsche einzugehen. Das Lieferprogramm wird ständig erweitert.

Komponenten der Firma Speedbrakes werden weltweit über verschiedene namhafte Firmen vertrieben.

Since 1995 Speed Brakes has been producing steel braided lines in highest quality. Speed Brakes steel braided lines go strong with their slim design and are available for every hydraulic brake. Due to in-house production Speed Brakes is able to meet the customer's needs individually. The product range is constantly expanded. Speed Brakes components are sold worldwide by many well-known companies.



In unserer Fertigung produzieren wir auf Bestellung komplette Leitungskits sowie Einzel- oder Sonderleitungen nach Maß oder Muster.

In unserer Datenbank befinden sich mehrere tausend Leitungskits, die wir unter genauer Angabe von Motorradmodell und Baujahr sofort abrufen und produzieren können.

Our database contains several thousands brake line kits but individual kits can be made by dimensions or example. A detailed usage list can be found on page 87.

Bremsleitungs kits für Motorräder mit ABE/TÜV Brake line kits for motorbikes with ABE/TÜV

Leitungskit Line kit
1-teilige Bremsleitung / 1-piece brake line
2-teiliges Bremsleitungskit (inkl. Doppelhohlschraube) 2-piece brake line kit (incl. double banjo bolt)
3-teiliges Bremsleitungskit / 3-piece brake line kit
4-teiliges Bremsleitungskit / 4-piece brake line kit
5-teiliges Bremsleitungskit / 5-piece brake line kit
6-teiliges Bremsleitungskit / 6-piece brake line kit
Bremsleitung hinten / rear brake line
Kupplungsleitung / clutch line
Superbike Oberleitung / superbike top brake line
Crossleitung / moto cross brake line

* Anschlüsse sind aus Aluminium und in folgenden Eloxalfarben lieferbar:

* Fittings made of aluminium and available in the following colors:

01 = silber / silver	04 = rot / red	08 = schwarz / black	10 = violett / violet
03 = blau / blue	05 = grün / green	09 = gold	11 = titan / titanium
20 = verchromt / chrome-plated	30 = Edelstahl / stainless steel		

** Alle Leitungen werden mit einer transp. Schlauchummantelung geliefert.

** Lines come in clear cover.

Farbige PVC-Ummantelung: Colored PVC-jacket:			
03 = blau / blue	05 = grün / green	08 = schwarz / black	14 = carbon look
04 = rot / red	06 = orange	09 = gelb / yellow	21 = weiß / white
33 = blau transparent / blue translucent	34 = rot transparent / red translucent	36 = orange transparent / orange translucent	88 = retro schwarz / retro black

Edelstahlanschlüsse

Für besondere Beanspruchung sind Leitungen auch mit Edelstahl-Anschlüssen lieferbar. Siehe ab Seite 44

Stainless-steel fittings

Lines also available with stainless-steel fittings for special demands. See page 44

Fahrzeugdatenbank:

Application database:

www.speedbrakes.ch/database

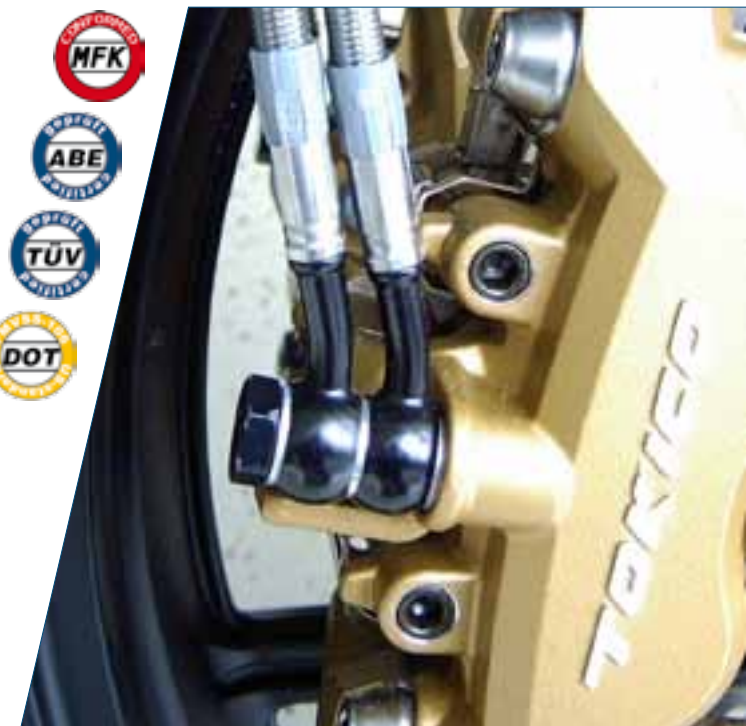

Einzelbremsleitungen nach Mass Single brake lines made to order

Einzeleitungen nach Maß oder Muster.

Wir produzieren Leitungen nach Maß oder Muster für ihr Motorrad. Schicken Sie uns dazu entweder ihre Originalleitung zu oder liefern Sie uns die gewünschten Bremsleitungsdaten (gemäß Skizze) und wir produzieren Ihnen Ihr individuelles Leitungskit.

We produce steel braided lines by dimensions or sample to order. For this purpose please send us your original brake line or the designated dimensions (see drawing).

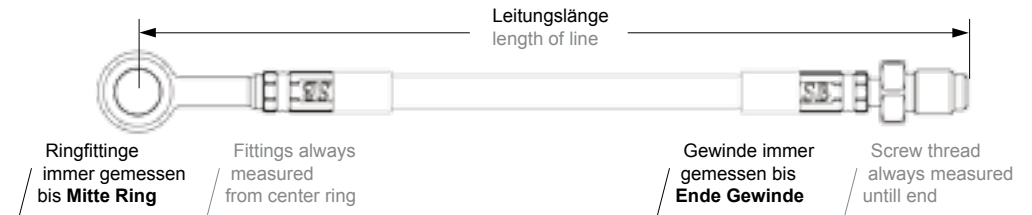

Fahrzeugdatenbank:
Application database:
www.speedbrakes.ch/database



Einzeleitungen mit fest verpressten Anschlüssen Single lines with crimped lines

Art.-Nr. art. no.	Länge length
50-101001	bis / to 010 cm
50-102001	bis / to 020 cm
50-103001	bis / to 030 cm
50-104001	bis / to 040 cm
50-105001	bis / to 050 cm
50-106001	bis / to 060 cm
50-107001	bis / to 070 cm
50-108001	bis / to 080 cm
50-109001	bis / to 090 cm
50-110001	bis / to 100 cm
50-111001	bis / to 110 cm
50-112001	bis / to 120 cm
50-113001	bis / to 130 cm
50-114001	bis / to 140 cm
50-115001	bis / to 150 cm
50-116001	bis / to 160 cm
50-117001	bis / to 170 cm
50-118001	bis / to 180 cm
50-119001	bis / to 190 cm
50-120001	bis / to 200 cm
50-121001	bis / to 210 cm
50-122001	bis / to 220 cm
50-123001	bis / to 230 cm
50-124001	bis / to 240 cm
50-125001	bis / to 250 cm



Die Anschlüsse sind aus Aluminium und in folgenden Eloxalfarben ohne Aufpreis lieferbar:
These Fittings are made of aluminium and available in the following colors without additional charge:

01 = silber / silver	08 = schwarz / black
03 = blau / blue	09 = gold
04 = rot / red	10 = violett / violet
05 = grün / green	11 = titan / titanium
20 = verchromt / chrome-plated	30 = Edelstahl / stainless steel

Alle Leitungen werden standardmäßig mit einer transp. PVC-Ummantelung geliefert.
Lines come in clear cover

Farbige PVC-Ummantelung: Colored PVC-jacket available:		
03 = blau / blue	08 = schwarz / black	88 = retro schwarz / retro black
04 = rot / red	09 = gelb / yellow	
05 = grün / green	14 = carbonlook	
06 = orange	21 = weiß / white	
33 = blau transparent / blue translucent	36 = orange transparent / orange translucent	
34 = rot transparent / red translucent		

Stahlleitungen

Für spezielle Anwendungen können wir Ihnen auch Stahlrohrleitungen in engen Bögen/Winkeln und mit individuellen Dichtkonusen herstellen.

Steel lines

We offer custom made Steel lines with close arches/angles and individual sealing cones.



Einzelleitungen für Autos mit fest verpressten Anschlüssen

Single lines for cars with crimped fittings

Art.-Nr. art. no.	Länge length
50-2010001	bis / to 010 cm
50-2020001	bis / to 020 cm
50-2030001	bis / to 030 cm
50-2040001	bis / to 040 cm
50-2050001	bis / to 050 cm
50-2060001	bis / to 060 cm
50-2070001	bis / to 070 cm
50-2080001	bis / to 080 cm
50-2090001	bis / to 090 cm
50-2100001	bis / to 100 cm
je weitere / every additional 10 cm	



Anschlüsse sind aus rostfreiem V2A Edelstahl

Fittings made of V2A stainless steel

Alle Leitungen werden mit einer transparenten PVC-Ummantelung geliefert.

Lines come in clear cover.

Farbige PVC-Ummantelung lieferbar:
Colored PVC-jacket available:

03 = blau / blue	05 = grün / green	08 = schwarz / black	14 = carbon look
04 = rot / red	06 = orange	09 = gelb / yellow	21 = weiß / white
33 = blau transparent / blue translucent	34 = rot transparent / red translucent	36 = orange transparent / orange translucent	88 = retro schwarz / retro black

Seit 2008 produziert MOTACC auch Stahlflexbremsleitungen für Autos.

MOTACC fertigt die Leitungen für Autos mit Edelstahlanschlüssen.

Edelstahl bietet gegenüber Aluminium oder Messinganschlüssen eine deutlich höhere Festigkeit und oxidiert nicht.

Diese Leitungen sind damit extrem widerstandsfähig und eignen sich ideal zum Einsatz im Renn- oder Rallysport sowie zum Einbau im Serienfahrzeug.

MOTACC has been producing steel braided lines for cars since 2008. Stainless steel fittings are much more durable and do not oxidise in comparison to aluminium. These lines are perfectly suited for use in racing or rallye sport but also for assembly in a production car.



Bremsleitungskits für Auto - mit TÜV + ABE

Steel braided line kits for cars - with TÜV + ABE

Leitungskit

Line kits

2-teiliger Bremsleitungssatz / 2-piece brake line kit
4-teiliger Bremsleitungssatz / 4-piece brake line kit
6-teiliger Bremsleitungssatz / 6-piece brake line kit
weitere Kits auf Anfrage / additional kits on request

Unser Vario System bietet höchste Flexibilität für den Fachhändler.

Beim Vario System handelt es sich um ein variables Schraubsystem für den professionellen Einsatz beim Fachhändler. Vorgefertigte Varioleitungen (der Händler hat diese an Lager) können unbegrenzt mit allen verfügbaren Anschlusskomponenten kombiniert werden.

Diese Kombinationsmöglichkeit erlaubt es dem Händler Lieferzeiten zu umgehen und dem Kunden direkt vor Ort ein individuelles Bremsleitungskit zusammenzustellen.

Vario Leitungen sind in beliebigen Längen sowie mit verschiedenen PVC-Ummantelungen lieferbar.

Vario Anschlüsse sind sowohl in Aluminium als auch in Edelstahl lieferbar. Diese Vielfalt ermöglicht den Einsatz des Vario Systems bei Motorrädern, Autos und Quads.

Gerne erarbeiten wir mit Ihnen zusammen ein speziell auf Ihre Kundschaft angepasstes Vario-Set. Unsere Erfahrung hilft Ihnen dabei, Ihren Lagerbestand so gering wie möglich zu halten und dennoch zu jedem Zeitpunkt lieferfähig zu sein.

The Vario system is a versatile system for professional use by specialized retailers. Pre-assembled steel braided lines, on stock, can be variously combined with any available fitting. The possible combinations allow the retailer to avoid delivery times and to assemble an individual brake line kit in-house.

Vario system lines are available in any length and in different line covers.

Vario system fittings are both available in aluminium and stainless steel. This variety allows the use for motorbike, cars and quads.

Feel free to contact us for an assorted Vario system kit matching the needs of your customers.



Anschlüsse / Fittings

Material Aluminium (9 Eloxalfarben) oder Edelstahl
Material material - aluminium (9 anodized colors) or stainless steel

Anschlüsse Wunschanschlüsse beliebig mit den Leitungen kombinierbar
Fittings designated fittings can be combined with every brake line

Leitungen / Brake lines

Material Stahlflex Vario Leitungen mit angepresstem Feingewinde
Material steel braided brake lines with crimped fine pitch thread

Farben 11 versch. Schlauchummantelungen
Colors 11 different cover colors available

Variokofferset mit Halterung siehe Seite 59
Vario kit with holder see page 59



Konusdichtung / Conical gasket

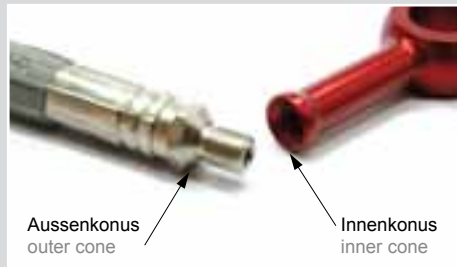

Anschlusskonusse sind optimal aufeinander abgestimmt und garantieren 100% Dichtheit. Tapered connection fittings are perfectly coordinated and guarantee 100% closeness.

Montage / Installation

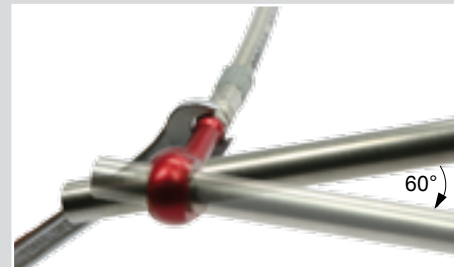

Verschraubung mit 60° Anzugsdrehmoment ohne Spezialwerkzeug. Bolting with 60° tightening torque without special tools.

Verdrehen / Adjusting



Auch beim Vario System sind die Anschlüsse nachträglich verdrehbar. Vario system with adjustable fittings.

Verlegung / Mounting



Durch das schlanke Variogewinde ist stets eine parallele Verlegung möglich. Parallel mounting due to slim Vario screw thread possible.



Bestellung / Art. Nr. für Vario Leitungen Order / Art. no. code for Vario lines

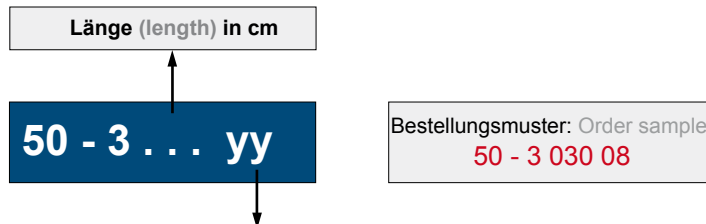

YY = Verfügbare Farben / Farbcode available colors / color code

00 = ohne / naked	01 = transparent / translucent	
03 = blau / blue	08 = schwarz / black	88 = retro schwarz / retro black
04 = rot / red	09 = gelb / yellow	
05 = kawa grün / green	14 = carbon look	
06 = orange	21 = weiß / white	
33 = blau transparent / blue translucent	36 = orange transparent	
34 = rot transparent / red translucent	/ orange translucent	

Farbe PVC-Umanteilung Color PVC-jacket

Stahlflex Vario Leitungen ohne Anschlüsse Vario steel braided lines without fittings

Art.-Nr. art. no.	Länge length
50-3 008 yy	008cm
50-3 009 yy	009cm
50-3 010 yy	010cm
50-3 011 yy	011cm
50-3 012 yy	012cm
50-3 013 yy	013cm
50-3 014 yy	014cm
50-3 015 yy	015cm
50-3 016 yy	016cm
50-3 017 yy	017cm
50-3 018 yy	018cm
50-3 019 yy	019cm
50-3 020 yy	020cm
50-3 021 yy	021cm
50-3 022 yy	022cm
50-3 023 yy	023cm
50-3 024 yy	024cm
50-3 025 yy	025cm
50-3 026 yy	026cm
50-3 027 yy	027cm
50-3 028 yy	028cm
50-3 029 yy	029cm
50-3 030 yy	030cm
50-3 031 yy	031cm
50-3 032 yy	032cm
50-3 033 yy	033cm
50-3 034 yy	034cm
50-3 035 yy	035cm
50-3 036 yy	036cm
50-3 037 yy	037cm
50-3 038 yy	038cm
50-3 039 yy	039cm
50-3 040 yy	040cm
50-3 041 yy	041cm
50-3 042 yy	042cm
50-3 043 yy	043cm
50-3 044 yy	044cm
50-3 045 yy	045cm
50-3 046 yy	046cm
50-3 047 yy	047cm
50-3 048 yy	048cm
50-3 049 yy	049cm
50-3 050 yy	050cm
50-3 051 yy	051cm
50-3 052 yy	052cm



Stahlflex Vario Leitungen ohne Anschlüsse
Vario steel braided lines without fittings

Art.-Nr. art. no.	Länge length
50-3 053 yy	053cm
50-3 054 yy	054cm
50-3 055 yy	055cm
50-3 056 yy	056cm
50-3 057 yy	057cm
50-3 058 yy	058cm
50-3 059 yy	059cm
50-3 060 yy	060cm
50-3 061 yy	061cm
50-3 062 yy	062cm
50-3 063 yy	063cm
50-3 064 yy	064cm
50-3 065 yy	065cm
50-3 066 yy	066cm
50-3 067 yy	067cm
50-3 068 yy	068cm
50-3 069 yy	069cm
50-3 070 yy	070cm
50-3 071 yy	071cm
50-3 072 yy	072cm
50-3 073 yy	073cm
50-3 074 yy	074cm
50-3 075 yy	075cm
50-3 076 yy	076cm
50-3 077 yy	077cm
50-3 078 yy	078cm
50-3 079 yy	079cm
50-3 080 yy	080cm
50-3 081 yy	081cm
50-3 082 yy	082cm
50-3 083 yy	083cm
50-3 084 yy	084cm
50-3 085 yy	085cm
50-3 086 yy	086cm
50-3 087 yy	087cm
50-3 088 yy	088cm
50-3 089 yy	089cm
50-3 090 yy	090cm
50-3 091 yy	091cm
50-3 092 yy	092cm
50-3 093 yy	093cm
50-3 094 yy	094cm
50-3 095 yy	095cm
50-3 096 yy	096cm
50-3 097 yy	097cm
50-3 098 yy	098cm

Stahlflex Vario Leitungen ohne Anschlüsse
Vario steel braided lines without fittings

Art.-Nr. art. no.	Länge length
50-3 099 yy	099cm
50-3 100 yy	100cm
50-3 101 yy	101cm
50-3 102 yy	102cm
50-3 103 yy	103cm
50-3 104 yy	104cm
50-3 105 yy	105cm
50-3 106 yy	106cm
50-3 107 yy	107cm
50-3 108 yy	108cm
50-3 109 yy	109cm
50-3 110 yy	110cm
50-3 111 yy	111cm
50-3 112 yy	112cm
50-3 113 yy	113cm
50-3 114 yy	114cm
50-3 115 yy	115cm
50-3 116 yy	116cm
50-3 117 yy	117cm
50-3 118 yy	118cm
50-3 119 yy	119cm
50-3 120 yy	120cm
50-3 121 yy	121cm
50-3 122 yy	122cm
50-3 123 yy	123cm
50-3 124 yy	124cm
50-3 125 yy	125cm
50-3 126 yy	126cm
50-3 127 yy	127cm
50-3 128 yy	128cm
50-3 129 yy	129cm
50-3 130 yy	130cm
50-3 135 yy	135cm
50-3 140 yy	140cm
50-3 145 yy	145cm
50-3 150 yy	150cm
50-3 155 yy	155cm
50-3 160 yy	160cm
50-3 165 yy	165cm
50-3 170 yy	170cm
50-3 175 yy	175cm
50-3 180 yy	180cm
50-3 185 yy	185cm
50-3 190 yy	190cm
50-3 195 yy	195cm
50-3 200 yy	200cm

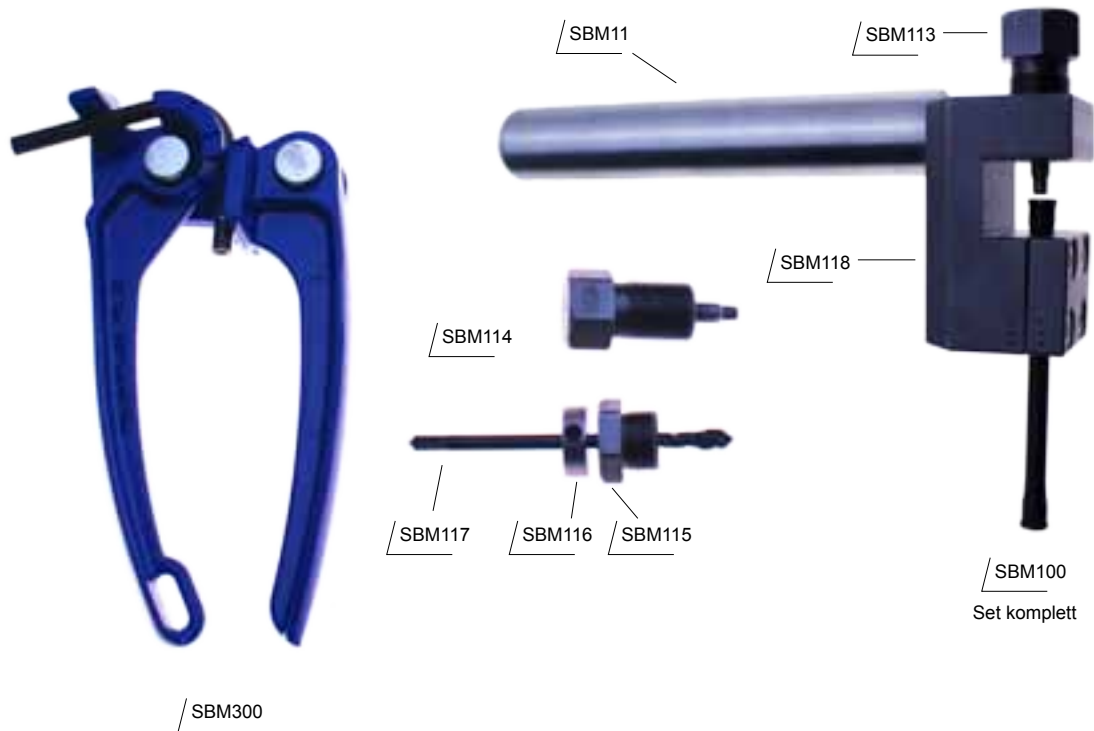

MARKTNEUHEIT - MARKET INNOVATION

Multifunktionswerkzeug
für flexibles Schraubsystem

NEW

Multifunctional tool
for flexible screw system

NEW

Im Komponenten-Werkzeugkasten erhältlich
Available in the component toolbox

Bestimmen Sie die Länge und die Winkel Ihrer Bremsleitungen mit schraubbaren Verbindungen selber!

Die Leitungen können ideal in den Rahmen oder in den Lenker verlegt werden. Weitere Anwendungen sind möglich, wie zum Beispiel der Ersatz eines Mittelteils, einer bereits verbauten Bremsleitung.

Design your own brake line by trimming and bending the screwable tube yourself!

These tubes can be inserted into frames and handlebars. Many other applications are possible – like the replacement of an intermediate part of an existing mounted brake line.



010



SBM160

Stahlrohre für Bremsleitungen / steel tube for brake lines

Art.-Nr. art. no.	Typ type	Bezeichnung description	Mass dimension
15-140900	010	Schraubensicherung Hochfest 10g / thread lock strong 10g	10g
95-4100010	SBM300	Hand-Rohrbiegegerät / hand-held tube bender	für Ø 3mm/5mm/6mm
95-4100011	SBM160	Rohrschneider / tube cutter	für Ø 3-16 mm / for steel tube
95-4100012	SBM100	Multifunktionswerkzeug Set komplett / complete multi tool kit	für Stahlrohr Ø 4.75mm / for steel tube
95-4100113	SBM113	Ausweitgewindebolzen No.1 zu Multifunktionswerkzeug / threaded flare bolt No. 1 for multi tool	für Stahlrohr Ø 4.75mm / for steel tube
95-4100114	SBM114	Ausweitgewindebolzen No.2 zu Multifunktionswerkzeug / threaded flare bolt No. 2 for multi tool	für Stahlrohr Ø 4.75mm / for steel tube
95-4100115	SBM115	Führungseinsatz für Gewindebohrer zu Multifunktionswerkzeug / tap holder for multi tool	für Stahlrohr Ø 4.75mm / for steel tube
95-4100116	SBM116	Gewindebohreranschlag zu Multifunktionswerkzeug / tap stopper for multi tool	für Stahlrohr Ø 4.75mm / for steel tube
95-4100117	SBM117	Gewindebohrer zu Multifunktionswerkzeug / screw tap for multi tool	für Stahlrohr Ø 4.75mm / for steel tube
95-4100118	SBM118	Spannblock zu Multifunktionswerkzeug / clamping block for multi tool	für Stahlrohr Ø 4.75mm / for steel tube
95-4100119	SBM119	Griff zu Spannblock-Multifunktionswerkzeug / clamping block handle for multi tool	für Stahlrohr Ø 4.75mm / for steel tube



Art.-Nr. 15-00300008 (300mm) ohne Gewinde



Art.-Nr. 15-00200008 (200mm) ohne Gewinde



Art.-Nr. 15-00100008 (100mm) ohne Gewinde



Art.-Nr. 15-30300008 (300mm) mit Gewinde

Art.-Nr. 15-30200008 (200mm) mit Gewinde

Art.-Nr. 15-30100008 (100mm) mit Gewinde



45°
Art.-Nr. 15-3410008

90°
Art.-Nr. 15-3910008

Stahlrohre für Bremsleitungen / steel tube for brake lines

Art.-Nr. art. no.	Bezeichnung description	Gewind screw thread	Steigung flank lead	Mass dimension	Farbe schwarz color black
15-0100008	ohne Innengewinde / without internal thread	-	-	AØ 4.75 mm x1000 mm	X
15-0090008	ohne Innengewinde / without internal thread	-	-	AØ 4.75 mm x900 mm	X
15-0080008	ohne Innengewinde / without internal thread	-	-	AØ 4.75 mm x800 mm	X
15-0070008	ohne Innengewinde / without internal thread	-	-	AØ 4.75 mm x700 mm	X
15-0060008	ohne Innengewinde / without internal thread	-	-	AØ 4.75 mm x600 mm	X
15-0050008	ohne Innengewinde / without internal thread	-	-	AØ 4.75 mm x500 mm	X
15-0040008	ohne Innengewinde / without internal thread	-	-	AØ 4.75 mm x400 mm	X
15-0030008	ohne Innengewinde / without internal thread	-	-	AØ 4.75 mm x300 mm	X
15-0020008	ohne Innengewinde / without internal thread	-	-	AØ 4.75 mm x200 mm	X
15-0010008	ohne Innengewinde / without internal thread	-	-	AØ 4.75 mm x100 mm	X
15-3010008	mit Innengewinde / with internal thread	M5	0.5	AØ 4.75 mm x100 mm	X
15-3020008	mit Innengewinde / with internal thread	M5	0.5	AØ 4.75 mm x200 mm	X
15-3030008	mit Innengewinde / with internal thread	M5	0.5	AØ 4.75 mm x300 mm	X
15-3040008	mit Innengewinde / with internal thread	M5	0.5	AØ 4.75 mm x400 mm	X
15-3050008	mit Innengewinde / with internal thread	M5	0.5	AØ 4.75 mm x500 mm	X
15-3060008	mit Innengewinde / with internal thread	M5	0.5	AØ 4.75 mm x600 mm	X
15-3070008	mit Innengewinde / with internal thread	M5	0.5	AØ 4.75 mm x700 mm	X
15-3080008	mit Innengewinde / with internal thread	M5	0.5	AØ 4.75 mm x800 mm	X
15-3090008	mit Innengewinde / with internal thread	M5	0.5	AØ 4.75 mm x900 mm	X
15-3100008	mit Innengewinde / with internal thread	M5	0.5	AØ 4.75 mm x1000 mm	X
15-3410008	mit Innengewinde / with internal thread	M5	0.5	AØ 4.75 mm x100 mm 45°	X
15-3910008	mit Innengewinde / with internal thread	M5	0.5	AØ 4.75 mm x100 mm 90°	X
15-131108	Schrumpfschlauch schwarz mit Klebstoff	-	-	Ø10 x 50 mm	X

Bremsleitungsrohre / brake line tubes Art.-Nr.

Art.-Nr. art. no.	Bezeichnung description	Farbe / Maß color / dimens.
Stahlrohr / steel tubes		
15-110000	Cunifer Kupfer/Stahlrohr	AØ 10mm
15-114750	Stahlrohr für Bremsleitungen	AØ 4.75 mm schwarz
15-116000	Stahlrohr für Bremsleitungen	AØ 6 mm schwarz
15-124750	Cunifer Kupfer/Stahlrohr	AØ 4.75 mm
15-126000	Cunifer Kupfer/Stahlrohr	AØ 6.00 mm
15-128000	Cunifer Kupfer/Stahlrohr	AØ 8.00 mm
15-134750	Kupfer/Bremsrohr	AØ 4.75 mm
15-136000	Kupfer/Bremsrohr	AØ 6.00 mm
15-138000	Kupfer/Bremsrohr	AØ 8.00 mm
15-0100008	Stahlrohr für Bremsleitungen	AØ 4.75 mm x1000 mm schwarz
15-0090008	Stahlrohr für Bremsleitungen	AØ 4.75 mm x900 mm schwarz
15-0080008	Stahlrohr für Bremsleitungen	AØ 4.75 mm x800 mm schwarz
15-0070008	Stahlrohr für Bremsleitungen	AØ 4.75 mm x700 mm schwarz
15-0060008	Stahlrohr für Bremsleitungen	AØ 4.75 mm x600 mm schwarz
15-0050008	Stahlrohr für Bremsleitungen	AØ 4.75 mm x500 mm schwarz
15-0040008	Stahlrohr für Bremsleitungen	AØ 4.75 mm x400 mm schwarz
15-0030008	Stahlrohr für Bremsleitungen	AØ 4.75 mm x300 mm schwarz
15-0020008	Stahlrohr für Bremsleitungen	AØ 4.75 mm x200 mm schwarz
15-0010008	Stahlrohr für Bremsleitungen	AØ 4.75 mm x100 mm schwarz



Set / Art.-Nr. 95-176000
38 Stück Rostfrei-Verschraubungen + 10m Kunifer-Rohre, Ø 4.75
Kit / art. no. 95-176000
38 pcs stainless thread screws + 10m cunifer tubes, Ø 4.75

Kunststoffbox-Set mit Edelstahlverschraubungen für Kunifer, Ø 4.75
Synthetic case set with stainless steel threads for cunifer, Ø 4.75

Art.-Nr. art. no.	Bezeichnung description	Mass dimension	Menge Quantity
20-141130	Aussengewinde beweglich - Edelstahl / flexible external thread - stainless	Typ 411 AGL M10 x 1.00 INOX f. Kunifer	10.00Stk. / pcs
20-142130	Aussengewinde beweglich - Edelstahl / flexible external thread - stainless	Typ 421 AGL M10 x 1.25 INOX f. Kunifer Ø 4.75	10.00Stk. / pcs
20-143130	Aussengewinde beweglich - Edelstahl / flexible external thread - stainless	Typ 431 AGL 3/8" -24 UNF f. Kunifer Ø 4.75	5.00Stk. / pcs
20-144130	Aussengewinde beweglich / flexible external thread - f. Kunifer Ø 4.75	Typ 441 AGL 7/16" -20 UNF Inox	2.00Stk. / pcs
20-146130	Aussengewinde beweglich / flexible external thread - f. Kunifer Ø 4.76	Typ 461 AGL 7/16" -24 UNF Inox	2.00Stk. / pcs
20-145130	Aussengewinde beweglich / flexible external thread - f. Kunifer Ø 4.77	Typ 451 AGL M12 x 1.00 Inox	2.00Stk. / pcs
20-251030	Doppelnippel fest / twoside threaded fitting fixed - 12mm Inox	Typ 2510 M10x1.00 - M10x1.00	2.00Stk. / pcs
24-471071050	Adapter Innen/Innengew. / adapter internal treaded - Messing/brass	Typ 710710 M10 x 1.00 /M10 x 1.00	2.00Stk. / pcs
24-471072050	Adapter Innen/Innengew. / adapter internal treaded - Messing/brass	Typ 710720 M10 x 1.00 /M10 x 1.25	2.00Stk. / pcs
24-475071050	Adapter Innen/Innengew. / adapter internal treaded - Messing/brass	Typ 750710 M12 x 1.00 /M10 x 1.00	1.00Stk. / pcs
15-124750	Kupfer/Stahlrohr / Cunifer tube	AØ 4.75 mm	10.00meter



Bördelwerkzeugset siehe Seite 60
Flaring tool kit see page 60

Speed Bleeder Schraube®
Speed Bleeder screw®

Art.-Nr. art. no.	Gewinde screw thread	Steigung flank lead	Länge length
29-72012949	M6	1.00	29mm
29-72053049	M7	1.00	30mm
29-72053549	M7	1.00	35mm
29-72113349	M8	1.00	33mm
29-72122849	M8	1.25	28mm
29-72123349	M8	1.25	33mm
29-72123849	M8	1.25	38mm
29-72213149	M10	1.00	31mm
29-72213449	M10	1.00	34mm
29-72223449	M10	1.25	34mm
29-72233249	M10	1.50	32mm
29-72742530	1/4"	28UNF	25mm
29-72762530	5/16"	24UNF	25mm
29-72773630	7/16"	20UNF	36mm
29-72783430	3/8"	24UNF	34mm
29-72783930	3/8"	24UNF	39mm

Zubehör / accessories

Art.-Nr. art. no.	Bezeichnung description	
29-72990100	Gewindedichtmasse gasket material thread	½ oz
15-250708	Kappe für Entlüfternippel cap for bleeder black	schwarz



Bremsen entlüften leicht gemacht. Mit Hilfe der patentierten Speed Bleeder®-Technik wird das Entlüften des Bremssystems zum Kinderspiel.

Egal, ob es um den Wechsel des kompletten Bremsleitungssatzes oder lediglich um das Nachfüllen bzw. Austauschen von Bremsflüssigkeit geht, in jedem Fall ist es nötig, das komplette Bremssystem zu entlüften. Wer die Anschaffung eines Druck oder Vakuum-Entlüftungssystems scheut, muss sein Bremssystem manuell entlüften. Es handelt sich dabei um einen zeitaufwendigen und komplizierten Prozess, der viel Geschick und Koordination erfordert.

Mit Hilfe der patentierten Speed Bleeder® Entlüfterschrauben, kann das Entlüften ohne technische Hilfsmittel und Kenntnisse, von einer einzigen Person, in nur wenigen Minuten erledigt werden:

Einfach die Entlüfterschraube um 1/4 Umdrehung öffnen und dann den Hand- oder Fußbremshebel betätigen. Durch den entstehenden Druck öffnet sich das Kugelventil und überschüssige Luft kann entweichen. In der Regel ist das Bremssystem nach nur fünfmaligem Pumpen vollständig entlüftet und die Entlüfterschraube kann wieder vollständig geschlossen werden.

Speed Bleeder - a truly one-person bleeder screw. When it is time to bleed your brakes, you loosen the Speed Bleeder 1/4 turn and pump your brake pedal. When the pedal is depressed the pressure generated opens the check valve letting air and brake fluid out of the end of the Speed Bleeder. When you release the pedal and it returns to the up position, the check valve closes and prevents any air from reentering the system through the Speed Bleeder. It generally takes about 5 pumps to purge each caliper or wheel cylinder. No additional tools required!

Ringfittige (Vario und festverpresst) Ring fittings (Vario and crimped)



08
schwarz / black

11
anthrazit / anthracite

20
verchromt / chrome-plated

09
gold

03
blau / blue

05
grün / green

04
rot / red

10
violett / violet

01
silber / silver

30
Edelstahl / stainless steel

l= Ringfittige nach links gebogen / ring connectors to the left bent
r= Ringfittige nach rechts gebogen / ring connectors to the right bent
s= Ringfittige seitlicher gebogen / ring connectors sideways bent

Lieferprogramm Ringfittige / Delivery program ring connectors

Art.-Nr. art. no.	Typ type	Kugelkopf Ø mm ball coupling Ø mm	Bohrung / Gewinde drilling / thread	Winkel / Steigung angle / flank lead	Länge in mm*** length in mm***	(z=1) festverpresst (z=1) crimped	(z=3) Vario (z=3) modular	Aluminium / aluminium										(yy=30) Edelstahl (yy=30) stainless steel				
								yy = 01	yy = 03	yy = 04	yy = 05	yy = 08	yy = 09	yy = 10	yy = 11	yy = 20**						
Ringfittige 10,2mm / Ring connectors 10,2mm																						
20-z00yy	000	18	10.2	0°	30	X	X	X	X	X	X	X	X	X	X	X	X	X	X	X	X	X
20-z001yy	001	18	10.2	0°	20	X	-	X	-	-	-	X	-	-	X	X	X	X	X	X	X	X
20-z002yy	002	18	10.2	20°	30	X	X	X	X	X	X	X	X	X	X	X	X	X	X	X	X	X
20-z003yy	003	18	10.2	30°	30	X	X	X	X	X	X	X	X	X	X	X	X	X	X	X	X	X
20-z004yy	004	18	10.2	45°	30	X	X	X	X	X	X	X	X	X	X	X	X	X	X	X	X	X
20-z006yy	006	18	10.2	60°	30	X	X	X	X	X	X	X	X	X	X	X	X	X	X	X	X	X
20-z014yy	014	18	10.2	45°	44	X	X	X	X	X	X	X	X	X	X	X	X	X	X	X	X	X
20-z017yy	017	18	10.2	70°	36	X	X	X	X	X	X	X	X	X	X	X	X	X	X	X	X	X
20-z019yy	019	18	10.2	90°	32	X	X	X	X	X	X	X	X	X	X	X	X	X	X	X	X	X
20-z020yy	020	18	10.2	20°s	28	X	X	X	X	X	X	X	X	X	X	X	X	X	X	X	X	X
20-z022yy	022	18	10.2	20°s/20°r	34	X	X	X	X	X	X	X	X	X	X	X	X	X	X	X	X	X
20-z024yy	024	18	10.2	45° / 20°	34	X	-	X	X	X	X	X	X	X	X	X	X	X	X	X	X	X
20-z032yy	032	18	10.2	20°s/20°l	34	X	X	X	X	X	X	X	X	X	X	X	X	X	X	X	X	X
20-z034yy	034	18	10.2	20° / 45°	34	X	-	X	X	X	X	X	X	X	X	X	X	X	X	X	X	X
20-z040yy	040	18	10.2	45°s	40	X	X	X	X	X	X	X	X	X	X	X	X	X	X	X	X	X
20-z090yy	090	18	10.2	90°s	26	X	X	X	X	X	X	X	X	X	X	X	X	X	X	X	X	X
Ringfittige 11,2mm / Ring connectors 11,2mm																						
20-z100yy	100	18	11.2	0°	30	X	X	X	-	-	-	X	X	-	X	X	X	X	X	X	X	X
20-z102yy	102	18	11.2	20°	30	X	X	X	-	-	-	X	X	-	X	X	X	X	X	X	X	X
20-z104yy	104	18	11.2	45°	30	X	X	X	-	-	-	X	X	-	X	X	X	X	X	X	X	X
20-z106yy	106	18	11.2	60°	30	X	X	X	-	-	-	X	X	-	X	X	X	X	X	X	X	X
20-z114yy	114	18	11.2	45°	44	X	X	X	-	-	-	X	X	-	X	X	X	X	X	X	X	X
20-z117yy	117	18	11.2	70°	36	X	X	X	-	-	-	X	X	-	X	X	X	X	X	X	X	X
20-z119yy	119	18	11.2	90°	32	X	X	X	-	-	-	X	X	-	X	X	X	X	X	X	X	X
20-z120yy	120	18	11.2	s20°	28	X	-	X	-	-	-	X	X	-	X	X	X	X	X	X	X	X
20-z140yy	140	18	11.2	s45°	40	X	X	X	-	-	-	X	X	-	X	X	X	X	X	X	X	X
20-z190yy	190	18	11.2	s90°	26	X	-	X	-	-	-	X	-	-	X	X	X	X	X	X	X	X
Ringfittige 12,2mm / Ring connector 12,2mm																						
20-z200yy	200	20	12.2	0°	30	X	ST*	X	-	-	-	X	X	-	X	X	X	X	X	X	X	X
20-z202yy	202	20	12.2	20°	30	X	X	X	-	-	-	X	X	-	X	X	X	X	X	X	X	X
20-z203yy	203	20	12.2	30°	30	X	-	X	-	-	-	X	-	-	X	-	-	X	X	X	X	X
20-z204yy	204	20	12.2	45°	30	X	-	X	-	-	-	X	-	-	X	-	-	X	X	X	X	X
20-z219yy	219	20	12.2	90°	32	X	X	X	-	-	-	X	-	-	X	-	-	X	X	X	X	X
20-z232yy	232	20	12.2	20° / 20°	34	X	X	X	-	-	-	X	-	-	X	-	-	X	X	X	X	X



000 Vario / modular

Siehe Angaben in der technischen Zeichnung
Look for informations in the technical drawing

ST* Keine Lagerware: Sonderteile werden auf Bestellung produziert.
Bitte längere Lieferzeiten einkalkulieren.
ST* Not in stock.
Special parts are made on order.
Please be aware of extended delivery times.

Verfügbare Farben / Farbcode

available colors / color code

- 01 = silber / silver 08 = schwarz / black
- 03 = blau / blue 09 = gold
- 04 = rot / red 10 = violett / violet
- 05 = grün / green 11 = anthrazit / anthracite

30 = Edelstahl / stainless steel

20 = verchromt / chrome-plated

Bestellung / Art. Nr. Order / Art. no. code

Z = 1 (festverpresst) 1 (crimped) Bestellmuster: 20 - 3 0600 04
Z = 3 (Vario) 3 (Vario) Order sample:

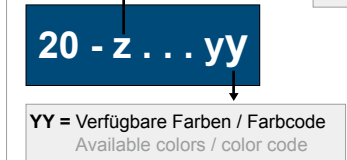

Ringfittings (Vario und festverpresst) Ring fittings (Vario and crimped)

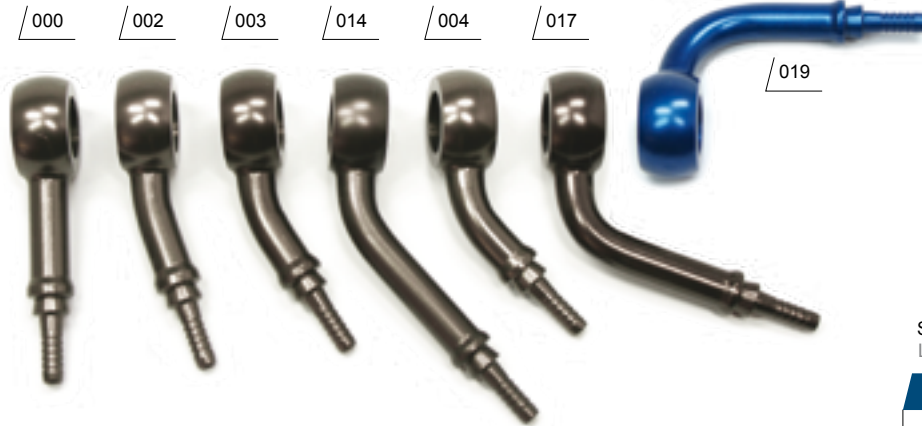

Verfügbare Farben / Farbcode
available colors / color code

01 = silber / silver	08 = schwarz / black
03 = blau / blue	09 = gold
04 = rot / red	10 = violett / violet
05 = grün / green	11 = anthrazit / anthracite
30 = Edelstahl / stainless steel	
20 = verchromt / chrome-plated	

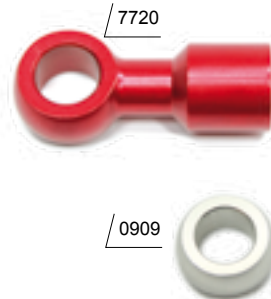

Bestellung / Art. Nr. Order / Art. no. code

Z= 1 (festverpresst) 1 (crimped)	Bestellungsmuster: Order sample:
Z= 3 (Vario) 3 (Vario)	20 - 3 0600 04
20 - z . . . yy	YY = Verfügbare Farben / Farbcode Available colors / color code

ST* Keine Lagerware:
Sonderteile werden auf
Bestellung produziert.
Bitte längere Lieferzeiten
einkalkulieren.
ST* Not in stock.
Special parts are made
on order.
Please consider
extended delivery times.

Siehe Angaben in der technischen Zeichnung
Look for informations in the technical drawing

s= Ringfittung seitlicher gebogen / ring connectors bent sideways

Lieferprogramm Ringfittings / Delivery program ring connectors

Art.-Nr. art. no.	Typ type	Kugelkopf Ø mm ball coupling Ø mm	Bohrung / Gewinde drilling / thread	Winkel / Steigung angle / flank lead	Länge in mm*** length in mm***	(z=1) festverpresst (z=1) crimped	(z=3) Vario (z=3) modular	Aluminium / aluminium										(yy=30) Edelstahl (yy=30) stainless steel							
								yy = 01	yy = 03	yy = 04	yy = 05	yy = 08	yy = 09	yy = 10	yy = 11	yy = 20**									
Ringfittings 6,2mm / Ring connectors 6,2mm																									
20-z0600yy	0600	14	6.2	0°	26	X	ST*	X	-	-	-	X	-	-	X	-	-								
20-z0602yy	0602	14	6.2	20°	26	X	-	X	-	-	-	X	-	-	X	X	-								
20-z0619yy	0619	14	6.2	90°	30	X	ST*	X	-	-	-	X	-	-	X	X	-								
20-z0690yy	0690	14	6.2	90°s	30	X	-	-	-	-	-	-	-	-	X	-	-								
Ringfittig 8,2mm / Ring connector 8,2mm																									
20-z0800yy	0800	15	8.2	0°	26	X	ST*	X	-	-	-	X	-	-	X	-	-	X							
20-z0801yy	0801	15	8.2	0°	16.5	X	-	X	-	-	-	X	-	-	X	-	-	-							
20-z0802yy	0802	15	8.2	20°	28	ST*	ST*	X	-	-	-	X	-	-	X	-	-	-							
20-z0803yy	0803	15	8.2	30°	28	X	-	X	-	-	-	X	-	-	X	-	-	-							
20-z0819yy	0819	15	8.2	90°	35	X	ST*	X	-	-	-	X	-	-	X	-	-	-							
20-z0890yy	0890	15	8.2	90°s	35	X	ST*	-	-	-	-	X	-	-	-	-	-	-							
Blindanschluss / Blind connector																									
20-1909yy	0909	18	10.2	-	-	-	-	X	-	-	-	X	-	-	-	-	-	-							
Ringfittings mit Innengewinde / Ring connectors with internal thread																									
24-7710yy	7710	18	10.2	1.00	33	-	-	X	X	X	-	X	X	-	X	-	-	-							
24-7720yy	7720	18	10.2	1.25	33	-	-	X	X	X	-	X	X	-	X	-	-	-							
24-7730yy	7730	18	10.2	3/8"-24UNF	33	-	-	X	-	X	-	X	-	-	X	-	-	-							
24-9710yy	9710	20	12.2	1.00	38	-	-	-	-	-	-	X	-	-	-	-	-	-							

Gewinde (Vario und festverpresst) Thread (Vario and crimped)



520

510

513

Siehe Angaben in der technischen Zeichnung
Look for informations in the technical drawing

k= konisch / conical p= parallel / parallel

Lieferprogramm Gewinde / Delivery program thread

Art.-Nr. art. no.	Typ type	Winkel / Steigung angle / flank lead	Bohrung / Gewinde drilling / thread	Gewindesteigung flank lead	Schlüsselweite wrench size	Länge Gewinde length thread	Länge Anschl.(mm) length fitting	(z=1) festverpresst (z=1) crimped	(z=3) Vario (z=3) modular	Aluminium / aluminium								(yy=30) Edelstahl (yy=30) stainless steel			
										yy = 01	yy = 03	yy = 04	yy = 05	yy = 08	yy = 09	yy = 10	yy = 11		yy = 20**		
Aussengewinde - fest / external thread - fixed																					
20-z510yy	510		M10	1.00	14	13	22	X	X	X	X	X	X	X	X	X	X	X	X	X	X
20-z511yy	511		M10	1.00	14	10	19	X	X	X	X	X	X	X	X	X	X	X	X	X	X
20-z513yy	513		M10	1.00	14	23	32	X	X	X	X	X	X	X	X	X	X	X	X	X	X
20-z514yy	514		M10	1.00	14	33	43	X	X	X	X	X	X	X	X	X	X	X	X	X	X
20-z520yy	520		M10	1.25	14	13	22	X	X	X	X	X	X	X	X	X	X	X	X	X	X
20-z521yy	521		M10	1.25	14	10	19	X	X	X	X	X	X	X	X	X	X	X	X	X	X
20-z530yy	530		3/8"	24UNF	14	13	22	X	X	X	X	X	X	X	X	X	X	X	X	X	X
20-z531yy	531		3/8"	24UNF	14	10	19	X	X	X	X	X	X	X	X	X	X	X	X	X	X
20-z533yy	533		3/8"	24UNF	14	23	32	X	X	X	X	X	X	X	X	X	X	X	X	X	X
20-z540yy	540		7/16"	20UNF	14	13	22	X	X	X	X	X	X	X	X	X	X	X	X	X	X
20-z541yy	541		7/16"	20UNF	14	11	20.5	X	X	X	X	X	X	X	X	X	X	X	X	X	X
20-z543yy	543		7/16"	20UNF	14	22.5	20.5	X	X	X	X	X	X	X	X	X	X	X	X	X	X
20-z550yy	550		M12	1.00	17	16	25.5	X	X	X	X	X	X	X	X	X	X	X	X	X	X
20-z560yy	560		7/16"	24UNS	14	13	22	X	X	X	X	X	X	X	X	X	X	X	X	X	X
20-z580yy	580		M8	1.00	14	10	19	X	X	X	X	X	X	X	X	X	X	X	X	X	X
20-z590yy	590		G1/8"	28 k	14	8.5	17	X	-	-	-	-	-	-	-	-	-	-	-	-	-
20-z591yy	591		G1/8"	28 p	14	8.5	17	X	X	X	X	X	X	X	X	X	X	X	X	X	X
20-z563yy	563		7/16"	24UNS	14	22.5	28	X	-	-	-	-	-	-	-	-	-	-	-	-	-
24-25006030	50060		M6	1.00	8	9.5	13	X	-	-	-	-	-	-	-	-	-	-	-	-	-
Aussengewinde - lose / external thread - swivel																					
20-z410yy	410	0°	M10	1.00	11	15	24	X	X	-	-	-	-	-	-	-	-	-	-	-	-
20-z411yy	411	für Kunifer	M10	1.00	11	13	17.5	-	-	-	-	-	-	-	-	-	-	-	-	-	-
20-z412yy	412	20°	M10	1.00	11	15	24	X	-	-	-	-	-	-	-	-	-	-	-	-	-
20-z413yy	413	30°	M10	1.00	11	15	40	X	-	-	-	-	-	-	-	-	-	-	-	-	-
20-z414yy	414	45°	M10	1.00	11	15	40	X	-	-	-	-	-	-	-	-	-	-	-	-	-
20-z417yy	417	70°	M10	1.00	11	15	38	X	-	-	-	-	-	-	-	-	-	-	-	-	-

Verfügbare Farben / Farbcode

available colors / color code

01 = silber / silver	08 = schwarz / black
03 = blau / blue	09 = gold
04 = rot / red	10 = violett / violet
05 = grün / green	11 = anthrazit / anthracite
30 = Edelstahl / stainless steel	
20 = verchromt / chrome-plated	

Bestellung / Art. Nr. Order / Art. no. code

Z= 1 (festverpresst) 1 (crimped)
Z= 3 (Vario) 3 (Vario)

Bestellungsmuster: Order sample:
20 - 1 530 03

20 - z . . . yy

YY = Verfügbare Farben / Farbcode
Available colors / color code

Bestellung / Art. Nr. Order / Art. no. code

Z= 1 (festverpresst) 1 (crimped)
Z= 3 (Vario) 3 (Vario)

Bestellungsmuster: Order sample:
20 - 1 610 04

20 - z . . . yy

YY = Verfügbare Farben / Farbcode
Available colors / color code



/ 710

Verfügbare Farben / Farbcode

available colors / color code

- 01 = silber / silver 08 = schwarz / black
- 03 = blau / blue 09 = gold
- 04 = rot / red 10 = violett / violet
- 05 = grün / green 11 = anthrazit / anthracite
- 30 = Edelstahl / stainless steel
- 20 = verchromt / chrome-plated



/ 619

Lieferprogramm Gewinde / Delivery program thread

Art.-Nr. art. no.	Typ type	Bohrung / Gewinde drilling / thread	Gewindesteigung flank lead	Schlüsselweite wrench size	Länge Gewinde length thread	Länge Anschl. length fitting	(z=1) festverpresst (z=1) crimped	(z=3) Vario (z=3) modular	Aluminium / aluminium								(yy=30) Edelstahl (yy=30) stainless steel																	
									yy = 01	yy = 03	yy = 04	yy = 05	yy = 08	yy = 09	yy = 10	yy = 11		yy = 20**																
Innengewinde - fest / internal thread - fixed																																		
20-z710yy	710	0°	M10	1.00	14	10	20	X	X	X	X	X	X	X	X	X	X	X	X	X	X	X	X	X										
20-z720yy	720	0°	M10	1.25	14	10	20	X	X	X	X	X	X	X	X	X	X	X	X	X	X	X	X	X										
20-z730yy	730	0°	3/8"	24UNF	14	10	20	X	X	X	X	X	X	X	X	X	X	X	X	X	X	X	X	X										
Innengewinde - lose / internal thread - swivel																																		
20-z610yy	610	0°	M10	1.00	14	8	19	X	X	X	X	X	X	X	X	X	X	X	X	X	X	X	X	X										
20-z611yy	611	0°	M10	1.00	14	8	19	X	X	X	X	X	X	X	X	X	X	X	X	X	X	X	X	X										
20-z612yy	612	20°	M10	1.00	14	8	38	X	X	X	X	X	X	X	X	X	X	X	X	X	X	X	X	X										
20-z614yy	614	45°	M10	1.00	14	8	38	X	X	X	X	X	X	X	X	X	X	X	X	X	X	X	X	X										
20-z617yy	617	70°	M10	1.00	19	8	22	X	X	X	X	X	X	X	X	X	X	X	X	X	X	X	X	X										
20-z618yy	618	90°	M10	1.00	14	9	16	X	X	X	X	X	X	X	X	X	X	X	X	X	X	X	X	X										
20-z619yy	619	90°	M10	1.00	14	8	16	X	X	X	X	X	X	X	X	X	X	X	X	X	X	X	X	X										
20-z620yy	620	0°	M10	1.25	14	8	15	X	X	X	X	X	X	X	X	X	X	X	X	X	X	X	X	X										
20-z621yy	621	0°	M10	1.25	14	8	15	X	X	X	X	X	X	X	X	X	X	X	X	X	X	X	X	X										
20-z622yy	622	20°	M10	1.25	14	8	38	X	X	X	X	X	X	X	X	X	X	X	X	X	X	X	X	X										
20-z624yy	624	45°	M10	1.25	14	8	38	X	X	X	X	X	X	X	X	X	X	X	X	X	X	X	X	X										
20-z627yy	627	70°	M10	1.25	14	8	22	X	X	X	X	X	X	X	X	X	X	X	X	X	X	X	X	X										
20-z628yy	628	90°	M10	1.25	14	9	16	X	X	X	X	X	X	X	X	X	X	X	X	X	X	X	X	X										
20-z629yy	629	90°	M10	1.25	14	8	16	X	X	X	X	X	X	X	X	X	X	X	X	X	X	X	X	X										
20-z630yy	630	0°	3/8"	24UNF	14	8	15	X	X	X	X	X	X	X	X	X	X	X	X	X	X	X	X	X										
20-z631yy	631	0°	3/8"	24UNF	14	8	15	X	X	X	X	X	X	X	X	X	X	X	X	X	X	X	X	X										
20-z632yy	632	20°	3/8"	24UNF	14	8	38	X	X	X	X	X	X	X	X	X	X	X	X	X	X	X	X	X										
20-z633yy	633	0°	3/8"	24UNF	11	10	19	X	X	X	X	X	X	X	X	X	X	X	X	X	X	X	X	X										
20-z634yy	634	45°	3/8"	24UNF	14	8	38	X	X	X	X	X	X	X	X	X	X	X	X	X	X	X	X	X										
20-z637yy	637	70°	3/8"	24UNF	14	8	22	X	X	X	X	X	X	X	X	X	X	X	X	X	X	X	X	X										
20-z638yy	638	90°	3/8"	24UNF	14	8	16	X	X	X	X	X	X	X	X	X	X	X	X	X	X	X	X	X										
20-z639yy	639	90°	3/8"	24UNF	14	8	16	X	X	X	X	X	X	X	X	X	X	X	X	X	X	X	X	X										
20-z690yy	690	0°	G 1/8"	28UNF	14	8	19	X	X	X	X	X	X	X	X	X	X	X	X	X	X	X	X	X										



/ 610

ST* Keine Lagerware: Sonderteile werden auf Bestellung produziert. Bitte längere Lieferzeiten einkalkulieren.
ST* Not in stock. Special parts are made on order. Please be aware of extended delivery times.

Siehe Angaben in der technischen Zeichnung
Look for informations in the technical drawing



4220

Lieferprogramm Hohlschrauben / Delivery program banjo bolts

Art.-Nr. art. no.	Typ type	Bezeichnung description	Gewinde screw thread	Steigung flank lead	Schlüsselweite wrench size	Aluminium / aluminium										(yy=30) Edelstahl (yy=30) stainless steel	
						yy = 01	yy = 03	yy = 04	yy = 05	yy = 08	yy = 09	yy = 10	yy = 11	yy = 20**			
Doppelhohlschrauben - spezial / double banjo bolt special																	
15-521049	5210	mit Bremslichtschalter*** / with brake light switch***	M10	1.00	14	X	-	-	-	-	-	-	-	-	-	-	-
15-522049	5220	mit Bremslichtschalter*** / with brake light switch***	M10	1.25	14	X	-	-	-	-	-	-	-	-	-	-	-
15-523049	5230	mit Bremslichtschalter*** / with brake light switch***	3/8"	24UNF	14	X	-	-	-	-	-	-	-	-	-	-	-
26-5061yy	5061	mit Entlüfternippel M6 / with bleeder	M10	1.00	14	X	-	-	-	X	-	-	-	-	-	-	-
26-5062yy	5062	mit Entlüfternippel M6 / with bleeder	M10	1.25	14	X	-	-	-	X	-	-	-	-	-	-	-
26-5010010yy	5010010	mit Innengew. M10x1.00 / with internal thread	M10	1.00	14	X	-	-	-	-	-	-	-	-	-	-	-
26-5020010yy	5020010	mit Innengew. M10x1.25 / with internal thread	M10	1.25	14	X	-	-	-	-	-	-	-	-	-	-	-
Zubehör / accessories																	
15-2506yy	2506	Entlüfternippel M6 / bleeder M6	M6	-	8	-	-	-	-	-	-	-	-	-	-	-	X
15-250708	2507	Kappe für Entlüfternippel**** / cap for bleeder****	-	-	-	-	-	-	-	-	-	-	-	-	-	-	-
15-411049	4110	Bremslichtschalter ohne Hohlschraube*** brake light switch without banjo bolt***	M10	1.00	14	X	-	-	-	-	-	-	-	-	-	-	-

*** Material: Stahl // Oberflächenbehandlung: gelb / blauverzinkt

*** Material: Stainless steel // finish yellow / blue galvanized

**** Material: Gummi

**** Material: rubber

Siehe Angaben in der technischen Zeichnung

Look for informations in the technical drawing



2507

4062

4310

5310



2506

Bestellung / Art. Nr. Order / Art. no. code

Bestellungsmuster: Order sample:

15 - 5210 01

15 - yy

YY = Verfügbare Farben / Farbcode
Available colors / color code

Verfügbare Farben / Farbcode

available colors / color code

01 = silber / silver	08 = schwarz / black
03 = blau / blue	09 = gold
04 = rot / red	10 = violett / violet
05 = grün / green	11 = anthrazit / anthracite
30 = Edelstahl / stainless	
20 = verchromt / chrome-plated	

Siehe Angaben in der technischen Zeichnung
Look for informations in the technical drawing

Lieferprogramm Hohlschrauben / Delivery program banjo bolts

Art.-Nr. art. no.	Typ type	Bezeichnung description	Gewinde screw thread	Steigung flank lead	Schlüsselweite wrench size	Aluminium / aluminium										(yy=30) Edelstahl (yy=30) stainless steel	
						yy = 01	yy = 03	yy = 04	yy = 05	yy = 08	yy = 09	yy = 10	yy = 11	yy = 20**			
Hohlschrauben / banjo bolt																	
25-4010yy	4010	Hohlschraube / banjo bolt	M10	1.00	14	X	X	X	X	X	X	X	X	X	X	X	X
25-4015yy	4015	Hohlschraube / banjo bolt	M10	1.50	14	-	-	-	-	-	-	-	-	-	-	-	X
25-4020yy	4020	Hohlschraube / banjo bolt	M10	1.25	14	X	X	X	X	X	X	X	X	X	X	X	X
25-4030yy	4030	Hohlschraube / banjo bolt	3/8"	24UNF	14	X	X	X	X	X	X	X	X	X	X	X	X
25-4040yy	4040	Hohlschraube / banjo bolt	7/16"	20UNF	15	X	-	-	-	X	-	-	-	-	-	-	X
25-4050yy	4050	Hohlschraube / banjo bolt	M12	1.00	17	X	-	-	-	-	-	-	-	-	-	-	X
25-4060yy	4060	Hohlschraube / banjo bolt	7/16"	24UNS	4	X	-	-	-	X	-	-	-	-	-	-	X
25-4008yy	4008	Hohlschraube / banjo bolt	M12	1.50	17	X	-	-	-	-	-	-	-	-	-	-	X
25-4080yy	4080	Hohlschraube / banjo bolt	M8	1.00	12	-	-	-	-	-	-	-	-	-	-	-	X
25-4082yy	4082	Hohlschraube / banjo bolt	M8	1.25	12	-	-	-	-	-	-	-	-	-	-	-	X
22-400060yy	400060	Hohlschraube M6x1.00 mit innensechskant SW4	M6	1.00	4	-	-	-	-	-	-	-	-	-	-	-	X
25-400061yy	400061	Hohlschraube M6x1.00 mit innensechskant SW10	M6	1.00	10	-	-	-	-	-	-	-	-	-	-	-	X
Doppelhohlschrauben / double banjo bolt																	
26-5010yy	5010	Doppelhohlschraube / double banjo bolt	M10	1.00	14	X	X	X	X	X	X	X	X	X	X	X	X
26-5020yy	5020	Doppelhohlschraube / double banjo bolt	M10	1.25	14	X	X	X	X	X	X	X	X	X	X	X	X
26-5030yy	5030	Doppelhohlschraube / double banjo bolt	3/8"	24UNF	14	X	X	X	X	X	X	X	X	X	X	X	X
26-5060yy	5060	Doppelhohlschraube / double banjo bolt	7/16"	24UNS	15	X	-	-	-	X	-	-	-	-	X	-	X
26-5080yy	5080	Doppelhohlschraube / double banjo bolt	M8	1.00	12	-	-	-	-	-	-	-	-	-	-	-	X
26-5082yy	5082	Doppelhohlschraube / double banjo bolt	M8	1.25	12	-	-	-	-	-	-	-	-	-	-	-	X
26-5008yy	5008	Doppelhohlschraube / double banjo bolt	M12	1.5	16	X	-	-	-	X	-	-	-	-	-	-	-
Hohlschrauben - spezial / banjo bolt - special																	
15-421049	4210	mit Bremslichtschalter*** / with brake light switch***	M10	1.00	14	X	-	-	-	-	-	-	-	-	-	-	-
15-422049	4220	mit Bremslichtschalter*** / with brake light switch***	M10	1.25	14	X	-	-	-	-	-	-	-	-	-	-	-
15-423049	4230	mit Bremslichtschalter*** / with brake light switch***	3/8"	24UNF	14	X	-	-	-	-	-	-	-	-	-	-	-
25-4061yy	4061	mit Entlüfternippel M6 / with bleeder	M10	1.00	14	X	-	-	-	X	-	-	-	-	-	-	X
25-4062yy	4062	mit Entlüfternippel M6 / with bleeder	M10	1.25	14	X	-	-	-	X	-	-	-	-	-	-	X
25-4010010yy	4010010	mit Innengew. M10x1.00 / with internal thread	M10	1.00	14	X	-	-	-	-	-	-	-	-	-	-	-
25-4020010yy	4020010	mit Innengew. M10x1.25 / with internal thread	M10	1.25	14	X	-	-	-	-	-	-	-	-	-	-	-
Hohlschrauben - Racing / banjo bolt - racing																	
24-4910yy	4910	Hohlschraube Racing * / banjo bolt racing	M10	1.00		X	-	-	-	X	-	-	-	-	-	-	-
24-4920yy	4920	Hohlschraube Racing * / banjo bolt racing	M10	1.25		X	-	-	-	X	-	-	-	-	-	-	-
27-5910yy	5910	Doppelhohlschraube Racing * / double banjo b. racing	M10	1.00		X	-	-	-	X	-	-	-	-	-	-	-
27-5920yy	5920	Doppelhohlschraube Racing * / double banjo b. racing	M10	1.25		X	-	-	-	X	-	-	-	-	-	-	-

*mit Sicherungsbohrloch

*with safety borehole



4010



4910



4020



5910



5010



5020



/970-KIT



/4010

/4020

/5010

/5020

Verfügbare Farben / Farbcode

available colors / color code

01 = silber / silver	08 = schwarz / black
03 = blau / blue	09 = gold
04 = rot / red	10 = violett / violet
05 = grün / green	11 = anthrazit / anthracite
30 = Edelstahl / stainless steel	
20 = verchromt / chrome-plated	

Bestellung / Art. Nr. Order / Art. no. code

Z= 1 (festverpresst) 1 (crimped)
Z= 3 (Vario) 3 (Vario)

Bestellungsmuster:
Order sample:
25 - 3 460 30

25 - z . . . yy

YY = Verfügbare Farben / Farbcode
Available colors / color code

siehe Seite 19
see page 19

Bestellung / Art. Nr. Order / Art. no. code
Verfügbare Farben / Farbcode available colors / color

Produktionsdetails / Production details



Hochpräzises Gewinde vom ersten bis zum letzten Gewindegang.

High-precision screw thread in every thread turn.



Abgerundeter Kopf und sanft gebrochene Kanten durch Trovalisierung minimieren Eloxalschäden beim Handling.

Rounded down head and rounded edges minimize damages during handling.



812



811



813



950



960



591



950



951



834



945



942

965

966

Lieferprogramm Kupplungen und Verteiler / Delivery program couplings and manifolds

Art.-Nr. art. no.	Typ type	Bezeichnung description	Schlüsselweite wrench size	Länge in mm length in mm	(z=1) festverpresst (z=1) crimped	(z=3) Vario (z=3) modular	Aluminium / aluminium										(yy=30) Edelstahl (yy=30) stainless steel	
							yy = 01	yy = 03	yy = 04	yy = 05	yy = 08	yy = 09	yy = 10	yy = 11	yy = 20**			
Doppelnippel - Adapter / twoside threaded fittings - adapter																		
24-2591510yy	591510	Doppelnippel fest BSP1/8- 8.5mm M10x1.00-13mm / twoside threaded fittings	14	27	-	-	X	-	-	-	X	-	-	-	-	-	-	
24-2591530yy	591530	Doppelnippel fest BSP1/8- 8.5mm UNF3/8-24G / twoside threaded fittings fix	14	27	-	-	X	-	-	-	X	-	-	-	-	-	-	
24-2511533yy	511533	Doppelnippel fest M10x1.0-UNF3/8-24 G Dash3 / twoside threaded fittings fix	14	27	-	-	X	-	-	-	X	-	-	-	-	-	-	
24-2521533yy	521533	Doppelnippel fest M10x1.25-UNF3/8-24 G Dash3 / twoside threaded fittings fix	14	27	-	-	X	-	-	-	X	-	-	-	-	-	-	
24-2515533yy	515533	Doppelnippel fest M10x1.5-UNF3/8-24 G Dash3 / twoside threaded fittings fix	14	27	-	-	X	-	-	-	X	-	-	-	-	-	-	
23-9591592yy	591592	Doppelnippel fest Spezial BSP1/8- UNEF 3/8-32 G / twoside threaded fittings fix spec.	14	27	-	-	-	-	-	-	-	-	-	-	-	-	X	
24-2531510yy	531510	Doppelnippel fest UNF3/8-24G- M10x1.00 / twoside threaded fittings fix	14	27	-	-	X	-	-	-	X	-	-	-	-	-	-	
24-2531533yy	531533	Doppelnippel fest UNF3/8-24G-UNF3/8-24 G Dash3 / twoside threaded fittings fix	14	27	-	-	X	-	-	-	X	-	-	-	-	-	-	
24-471052050	710520	Adapter Innen/Aussengew. M10x1-10x1.25 Messing / inside/outside	13	30	-	-	-	-	-	-	-	-	-	-	-	-	-	
24-471055050	710550	Adapter Innen/Aussengew. M10x1/12x1 Messing / inside/outside	13	30	-	-	-	-	-	-	-	-	-	-	-	-	-	
24-471071050	710710	Adapter Innen/Innengew. M10x1 Messing / inside/inside	14	23	-	-	-	-	-	-	-	-	-	-	-	-	-	
24-471072050	710720	Adapter Innen/Innengew. M10x1-10x1.25 Messing / inside/inside	14	23	-	-	-	-	-	-	-	-	-	-	-	-	-	
24-472057050	720570	Adapter Innen/Aussengew. M10x1.25/12x1.25 Messing / inside/outside	13	30	-	-	-	-	-	-	-	-	-	-	-	-	-	
24-475051050	750510	Adapter Innen/Aussengew. M12x1/10x1 Messing / inside/outside	14	30	-	-	-	-	-	-	-	-	-	-	-	-	-	
24-475071050	750710	Adapter Innen/Innengew. M12x1/M10x1 Messing / inside/inside	17	27	-	-	-	-	-	-	-	-	-	-	-	-	-	
Kupplungen / junctions																		
25-z960yy	960	Vario Kupplung innen - innen / vario junctions inside - inside	M5	0.5	8	16	X	X	-	-	-	-	-	-	-	-	-	X
25-z961yy	961	Vario Kupplung aussen - aussen / vario junctions outside - outside	M5	0.5	8	8	-	X	-	-	-	-	-	-	-	-	-	X
25-z963yy	963	Verschlusschraube Vario / plug screw	M5	0.5	8	3	-	X	-	-	-	-	-	-	-	-	-	X
24-z970yy	970	Spezialanschluss für Bremsleitungsverlängerung / special junction			16	19	X	X	X	-	-	X	-	-	-	-	-	-
24-4510710yy	10710	Leitungsverlängerung flächendichtend 40mm / line extension *	M10	1.00	14	-	-	-	X	-	-	X	-	-	-	-	-	-
24-4520720yy	20720	Leitungsverlängerung flächendichtend 40mm / line extension *	M10	1.25	14	-	-	-	X	-	-	X	-	-	-	-	-	-

*surface seal

Bestellung / Art. Nr. Order / Art. no. code

Z= 1 (festverpresst) 1 (crimped) Bestellmuster: Order sample:
 Z= 3 (Vario) 3 (Vario) **25 - 1 960 30**

24 - z . . . yy → YY = Verfügbare Farben / Farbcode
 Available colors / color code

01 = silber / silver 08 = schwarz / black
 03 = blau / blue 09 = gold
 04 = rot / red 10 = violett / violet
 05 = grün / green 11 = anthrazit / anthracite

30 = Edelstahl / stainless steel

20 = verchromt / chrome-plated

Siehe Angaben in der technischen Zeichnung
 Look for informations in the technical drawing



750510



710710



970

10710



511533



Hohlschrauben mit Entlüftungsnippel männlich (973 + 974)

- dauerhaft an der Bremsleitung verbaut
- tropfenfreie Entlüftung
- schnellstmögliches Entlüften
- inkl. Schutzkappe aus eloxiertem Aluminium

Banjo bolt with bleeding nipple male (973 + 974)

- permanently installed together with brake line
- non-spill bleeding
- for quickest possible bleeding
- incl. protection cover made of anodized aluminium



973

Schnelles ab- und ankoppeln der Bremsleitungen ohne zu entlüften!

Quick connection of the brake lines – no bleeding required!



M10x1

968

Art.-Nr. 25-396801

967

Art.-Nr. 25-396701

Vario M5x0.5

966

Art.-Nr. 25-396601

M10x1

965

Art.-Nr. 25-396501

Vario M5x0.5

974

973

965

966

Entlüftungsnippel direktverschraubt männlich (971)

- dauerhaft verbaut
- tropfenfreie Entlüftung
- schnellstmögliches Entlüften
- inkl. Schutzkappe aus eloxiertem Aluminium

Bleeding nipple for direct assembly male (971)

- permanently installed
- non-spill bleeding
- for quickest possible bleeding
- incl. protection cover made of anodized aluminium

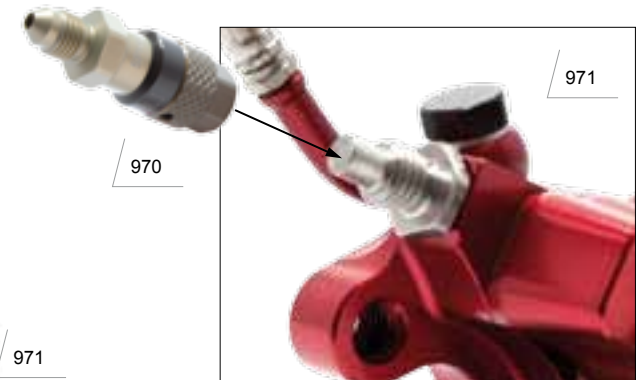

971

970

Schnellentlüftungskupplung weiblich (970)

- für Hohlschraube mit Entlüftungsnippel und direktverschraubtem Entlüftungsnippel geeignet
- Einfaches Aufschrauben auf Entlüftungsnippel zum Entlüften
- Tropfenfreies Entfernen nach dem Entlüften

Quick connector bleeding female (970)

- for use with banjo bolt with bleeding nipple male as well as with bleeding nipple for direct assembly
- simply screwed on the bleeding nipple for bleeding
- non-spill remove after bleeding



/136



/091



/073



/1204

/1304



/HK-70

Sonstiges Zubehör / Accessories

Art.-Nr. art. no.	Typ type	Bezeichnung description	Farbe / Maß1 color / dims.1	Maß2 dims.2
Verschiedenes / various				
24-200850	008	Messing-Oliven aussen-aussen / brass-olives outside-outside	Ø 8mm	120°
24-201050	010	Messing-Oliven innen-innen / brass-olives inside-inside	Ø 10mm	90°
24-285050	850	Messing-Oliven innen-innen / brass-olives inside-inside	Ø 8mm	90°
24-285150	851	Messing-Oliven aussen-aussen / brass-olives outside-outside	Ø 8mm	120°
15-140800	1408	Schraubensicherung hochfest / screw locking	10g	
95-410132	KX3	Drei-Dorn Spreizzange / spreader forceps		
Spiralschläuche / spiral coiled tubes				
15-132000	132	Spiralschlauch / spiral coiled tube	transparent / clear	
15-132003	132	Spiralschlauch / spiral coiled tube	blau / blue	
15-132004	132	Spiralschlauch / spiral coiled tube	rot / red	
15-132008	132	Spiralschlauch / spiral coiled tube	schwarz / black	
15-132009	132	Spiralschlauch / spiral coiled tube	gelb / yellow	
Spezialschläuche / special tubes				
15-123008	123	Wellschlauch / corrugated tube	schwarz / black	
15-124008	124	Flechtschlauch / braided sleeve	schwarz / black	
15-136008	136	Bremsflüssigkeitsschlauch / brake fluid tube	schwarz / black	I-Ø 07 / A-Ø 12
Zubehör Crossmotorräder / accessories crossbikes				
15-123508	1235	Crossummantelung / cross sleeve PE - Vario	schwarz / black	Ø12 x 10 x 1
15-122508	1225	Crossummantelung / cross sleeve PE - Standard	schwarz / black	Ø10 x 08 x 1
15-122608	1226	Crossrohr PE - extra steif / cross pipe - extra inflexible	schwarz / black	Ø12 x 08 x 2
15-131108	1311	Schrumpfschlauch + Klebstoff / heat shrink tube + glue	schwarz / black	50mm
15-253073	073	Knickschutztülle / anti-kink grommet	41mm	
15-253091	091	Knickschutztülle / anti-kink grommet	85mm	
15-201062	A2K	Gummitülle für Crossleitungen / grommet for cross line kits	schwarz / black	30mm
Alu-Dichtringe / alu seal rings				
15-120100	1201	Alu-Dichtring / alu seal ring 05mm	I-Ø 05mm	A-Ø 09
15-120200	1202	Alu-Dichtring / alu seal ring 06mm	I-Ø 06mm	A-Ø 10
15-120300	1203	Alu-Dichtring / alu seal ring 08mm	I-Ø 08mm	A-Ø 12
15-120800	1208	Alu-Dichtring / alu seal ring 08mm	I-Ø 08mm	A-Ø 14
15-120400	1204	Alu-Dichtring / alu seal ring 10mm	I-Ø 10mm	A-Ø 14
15-120500	1205	Alu-Dichtring / alu seal ring 10mm	I-Ø 10mm	A-Ø 16
15-120900	1209	Alu-Dichtring / alu seal ring 11mm	I-Ø 11mm	A-Ø 15
15-120600	1206	Alu-Dichtring / alu seal ring 12mm	I-Ø 12mm	A-Ø 16
15-120700	1207	Alu-Dichtring / alu seal ring 12mm	I-Ø 12mm	A-Ø 19



/004



/001

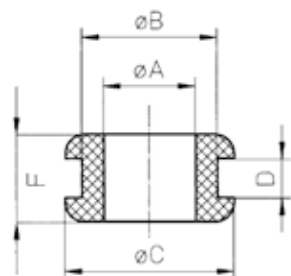

/HK-99



/CN-10



/CN-08



/CX-09



/KX3



/KX3 + A2K

Sonstiges Zubehör / Accessories

Art.-Nr. art. no.	Typ type	Bezeichnung description	Farbe / Maß1 color / dimens.1	Maß2 dimens.2
Kupfer Dichtringe / copper seal rings				
15-130100	1301	Kupfer-Dichtring 5mm / copper seal ring 5mm	I-Ø 5mm	A-Ø 9mm
15-130200	1302	Kupfer-Dichtring 6mm / copper seal ring 6mm	I-Ø 6mm	A-Ø 10mm
15-130300	1303	Kupfer-Dichtring 8mm / copper seal ring 8mm	I-Ø 8mm	A-Ø 12mm
15-130400	1304	Kupfer-Dichtring 10mm / copper seal ring 10mm	I-Ø 10mm	A-Ø 14mm
15-130900	1309	Kupfer-Dichtring 11mm / copper seal ring 11mm	I-Ø 11mm	A-Ø 15mm
15-130600	1306	Kupfer-Dichtring 12mm / copper seal ring 12mm	I-Ø 12mm	A-Ø 16mm
Kunststoffhalter / plastic mounts				
15-1306575	RH-27	Kunststoffhalter / plastic mount	schwarz / black	
15-3409118	CX-09	Kunststoffhalter M4 - verstellbar / plastic mount M4 - adjustable	schwarz gummiert / black rubberized	Klemm / clamp - Ø 9mm
15-3413108	CX-13	Kunststoffhalter M4 - verstellbar / plastic mount M4 - adjustable	schwarz / black	Klemm / clamp - Ø 13mm
15-3508008	CN-08	Kunststoffhalter M5 / plastic mount M5	schwarz / black	Klemm / clamp - Ø 8mm
15-3508018	CN-08	Kunststoffhalter M5 / plastic mount M5	schwarz gummiert / black rubberized	Klemm / clamp - Ø 8mm
15-3510008	CN-10	Kunststoffhalter M5 / plastic mount M5	schwarz / black	Klemm / clamp - Ø 10mm
15-3000003	HK-03	Halterkit Spezial für Auto, mit Gummi + Clip / special car mount, w. rubber	schwarz / black Clip Ø 16mm	Klemm / clamp - Ø 8mm
15-3200008	HK-70	Halterkit Spezial für Auto, Halterung verschraubbar, ohne Gummi / special car mount, screwable, w/o rubber	schwarz / black Ø 16mm verschraubt	Klemm / clamp - Ø 8mm
15-3900101	HK-80	Halterkit Spezial für Auto / special car mount	silber / silver	Ø1 7.5 / Ø2 8.5
15-3900102	HK-85	Halterkit Spezial für Auto Edelstahl / special car mount stainless steel	schwarz gummiert / black rubberized	Ø 7 / Ø 8.5 / Ø 21mm
15-3907108	HK-99	Halterkit für 710/720/730 / mount for 710/720/730	schwarz / black	Klemm / clamp - Ø 14mm
Gummitüllen / grommets				
15-252001	001	Durchführunggummitülle Ø-A 7 / grommet Ø-A 7	Ø-B 14 // Ø-C 20	D 15 // F 19
15-252220	220	Durchführunggummitülle Ø-A 7 / grommet Ø-A 7	Ø-B 25 // Ø-C 29	D 06 // F 10
15-257019	019	Durchführunggummitülle Ø-A 7,5 / grommet Ø-A 7,5	Ø-B 12 // Ø-C 16	D 13 // F 18
15-252110	110	Durchführunggummitülle Ø-A 7,5 / grommet Ø-A 7,5	Ø-B 11 // Ø-C 20	D 05 // F 12
15-252092	092	Durchführunggummitülle Ø-A 7,5 / grommet Ø-A 7,5	Ø-B 12 // Ø-C 20	D 03 // F 10
15-252157	157	Durchführunggummitülle Ø-A 8 / grommet Ø-A 8	Ø-B 11 // Ø-C 15	D 04 // F 11
15-252028	028	Durchführunggummitülle Ø-A 8 / grommet Ø-A 8	Ø-B 10 // Ø-C 15	D 01 // F 08
15-252166	166	Durchführunggummitülle Ø-A 12 / grommet Ø-A 12	Ø-B 18 // Ø-C 25	D 04 // F 09
15-252004	004	Durchführunggummitülle Ø-A 7 / grommet Ø-A 7	Ø-B 18 // Ø-C 25	D 04 // F 22



/RH27



/2008



/2009



/HK85



/1408

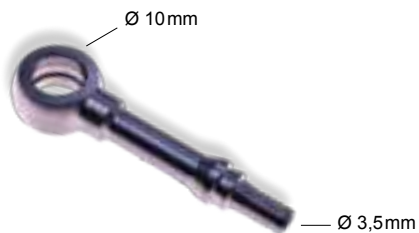

00040
Art.-Nr. 23-10004030



01740
Art.-Nr. 23-10174030



01940
Art.-Nr. 23-10194030

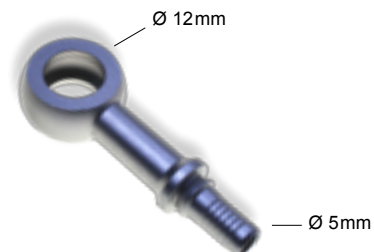

00060
Art.-Nr. 27-590001



51415
Art.-Nr. 22-5141501



71415
Art.-Nr. 22-7141501

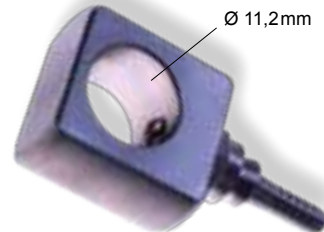

011
Art.-Nr. 23-301130



945
Art.-Nr. 26-194530



591592
Art.-Nr. 24-259159230



692
Art.-Nr. 20-169230



4011
Art.-Nr. 23-2401130



4012
Art.-Nr. 23-2401230



900 konvex / convex
Art.-Nr. 26-690008

901 konkav / concave
Art.-Nr. 26-690108



810
Art.-Nr. 26-681008



8813
Art.-Nr. 26-881301



700
Art.-Nr. 15-9700008



789
Art.-Nr. 20-178930



7712
Art.-Nr. 24-771201



HK003
Art.-Nr. 15-300003



RH27
Art.-Nr. 15-13065675

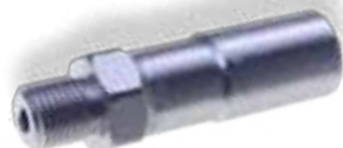

10710 M10x1.00
Art.-Nr. 24-45107101

20720 M10x1.25
Art.-Nr. 24-45207201



699
Art.-Nr. 24-169930



483
Art.-Nr. 20-148330



473
Art.-Nr. 20-147330

Ringfittige 6,2mm

ring connectors 6,2mm

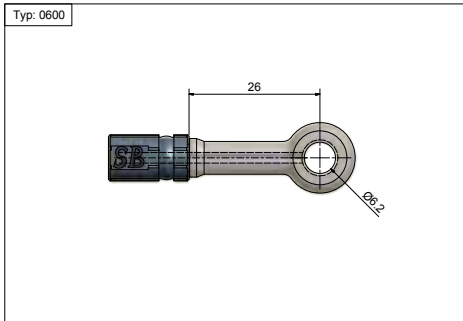

01 03 04 05 08 09 10 11 20 30

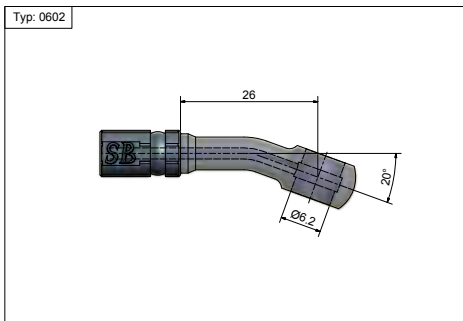

01 03 04 05 08 09 10 11 20 30

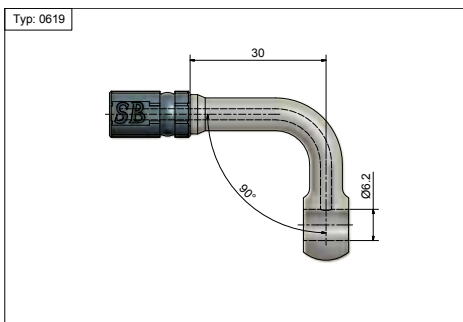

01 03 04 05 08 09 10 11 20 30

Ringfittige 8,2mm

ring connectors 8,2mm

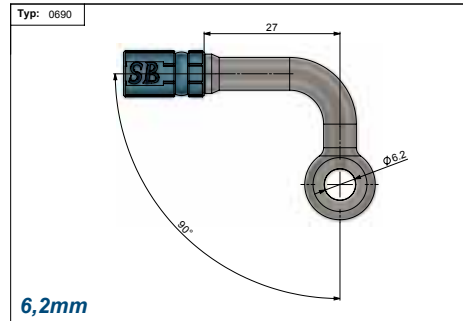

6,2mm

01 03 04 05 08 09 10 11 20 30

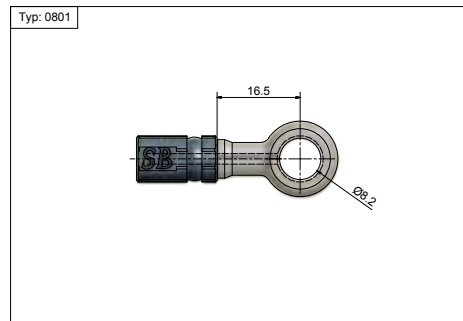

01 03 04 05 08 09 10 11 20 30

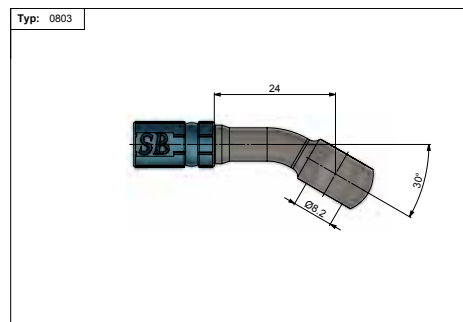

01 03 04 05 08 09 10 11 20 30

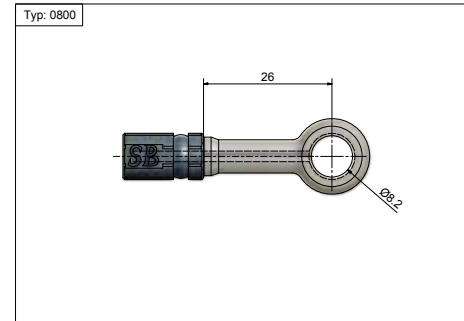

01 03 04 05 08 09 10 11 20 30

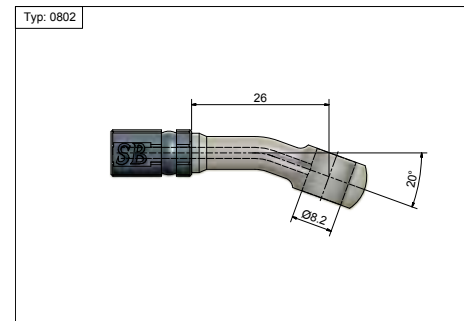

01 03 04 05 08 09 10 11 20 30

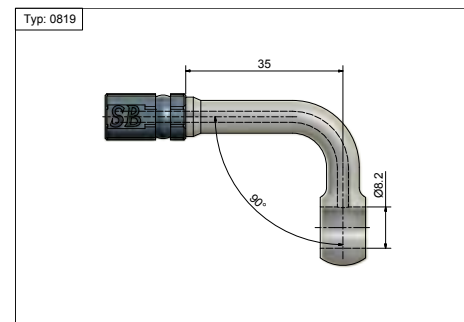

01 03 04 05 08 09 10 11 20 30

 **Unterstrichen = Teil in dieser Farbe verfügbar**
weitere Farben auf Anfrage
Underlined = part in this color available
other colors on request

-  01 = silber / silver
-  03 = blau / blue
-  04 = rot / red
-  05 = grün / green
-  08 = schwarz / black
-  09 = gold
-  10 = violett / violet
-  11 = anthrazit / anthracite
-  20 = verchromt / chrome-plated
-  30 = Edelstahl / stainless steel

Ringfittings 10,2mm
ring connectors 10,2mm

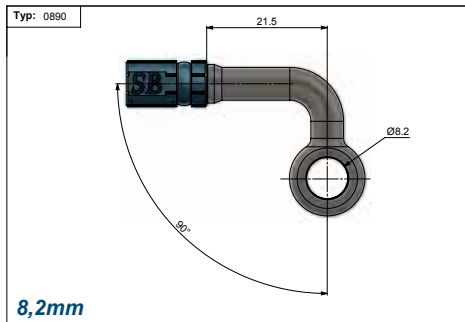

01 03 04 05 08 09 10 11 20 30

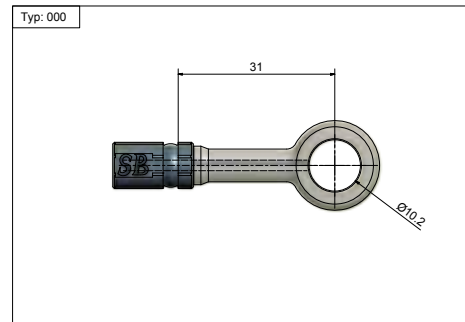

01 03 04 05 08 09 10 11 20 30

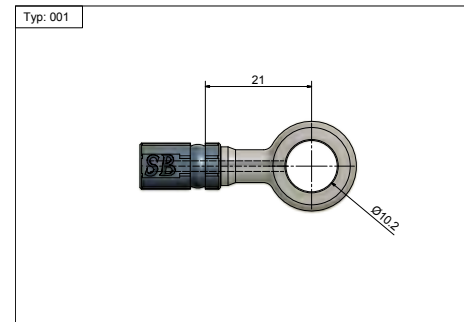

01 03 04 05 08 09 10 11 20 30

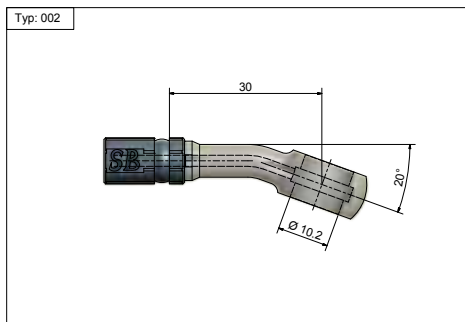

01 03 04 05 08 09 10 11 20 30

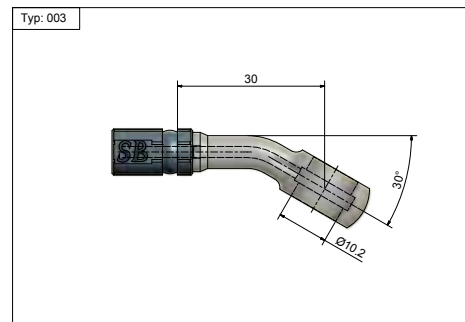

01 03 04 05 08 09 10 11 20 30

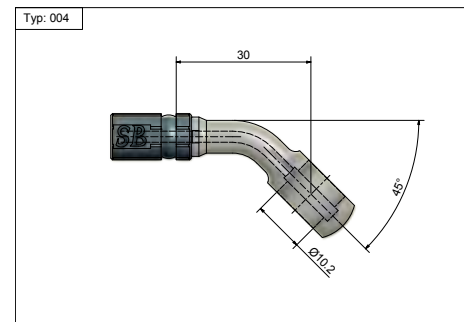

01 03 04 05 08 09 10 11 20 30

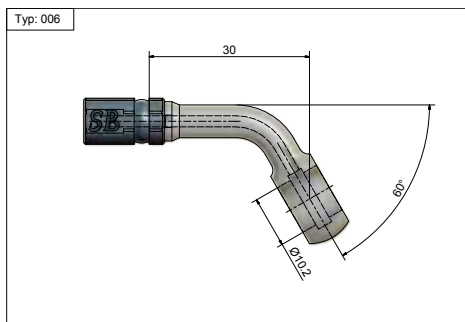

01 03 04 05 08 09 10 11 20 30

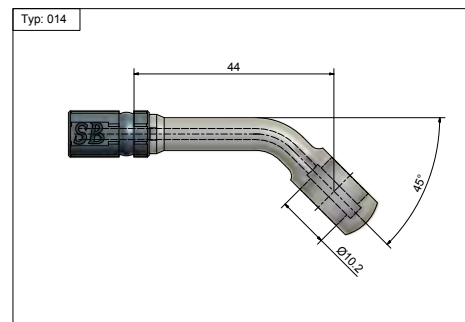

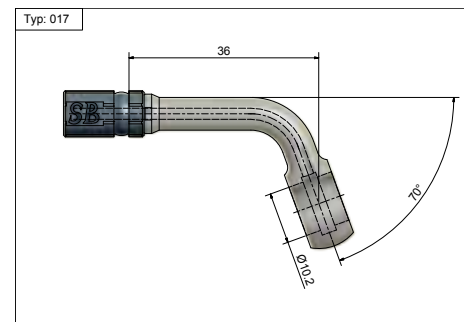

01 03 04 05 08 09 10 11 20 30



01 03 04 05 08 09 10 11 20 30

 **Unterstrichen = Teil in dieser Farbe verfügbar**
weitere Farben auf Anfrage
Underlined = part in this color available
other colors on request

-  01 = silber / silver
-  03 = blau / blue
-  04 = rot / red
-  05 = grün / green
-  08 = schwarz / black
-  09 = gold
-  10 = violett / violet
-  11 = anthrazit / anthracite
-  20 = verchromt / chrome-plated
-  30 = Edelstahl / stainless steel

Ringfittige 10,2mm
ring connectors 10,2mm

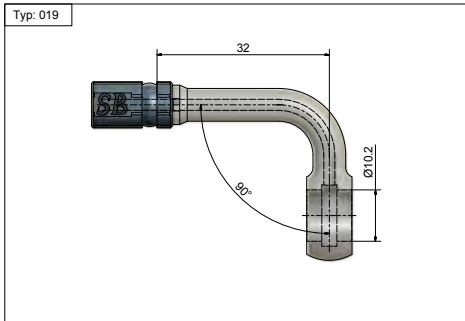

01 03 04 05 08 09 10 11 20 30

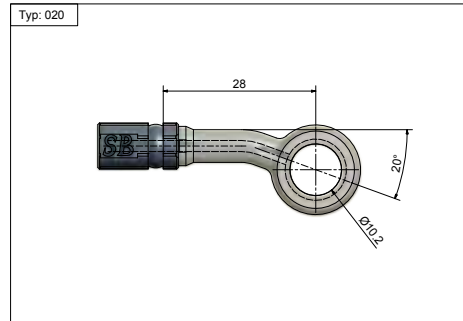

01 03 04 05 08 09 10 11 20 30

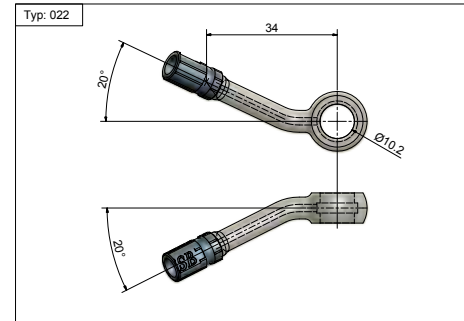

01 03 04 05 08 09 10 11 20 30

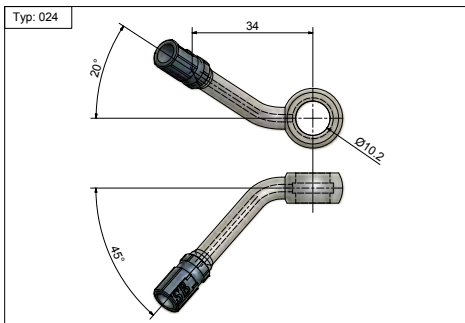

01 03 04 05 08 09 10 11 20 30

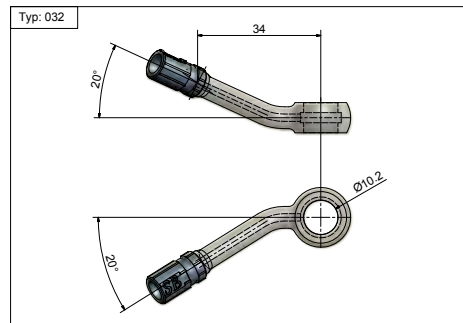

01 03 04 05 08 09 10 11 20 30

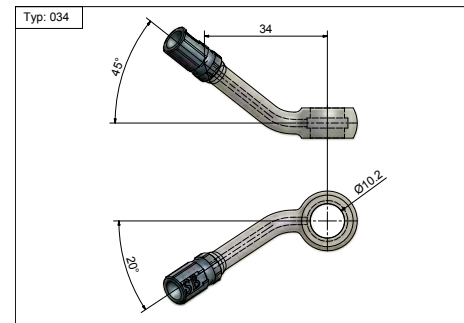

01 03 04 05 08 09 10 11 20 30

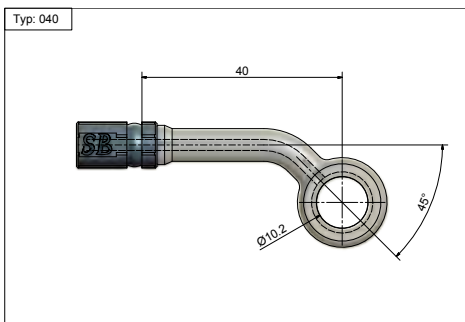

01 03 04 05 08 09 10 11 20 30

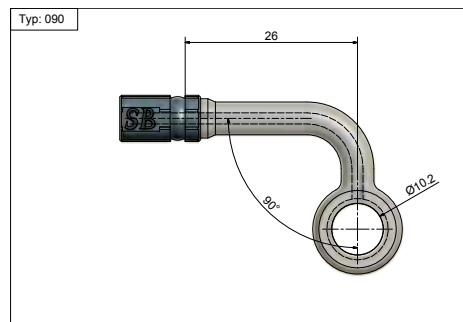



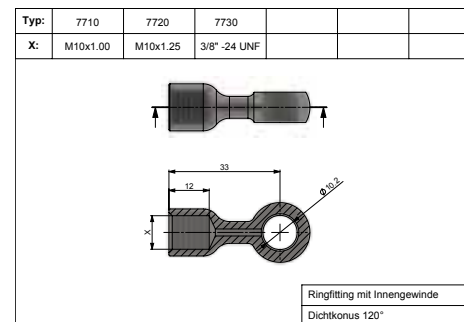

01 03 04 05 08 09 10 11 20 30



01 03 04 05 08 09 10 11 20 30

 **Unterstrichen = Teil in dieser Farbe verfügbar**
weitere Farben auf Anfrage
Underlined = part in this color available
other colors on request

-  01 = silber / silver
-  03 = blau / blue
-  04 = rot / red
-  05 = grün / green
-  08 = schwarz / black
-  09 = gold
-  10 = violett / violet
-  11 = anthrazit / anthracite
-  20 = verchromt / chrome-plated
-  30 = Edelstahl / stainless steel

Ringfittinge 11,2mm
ring connectors 11,2mm

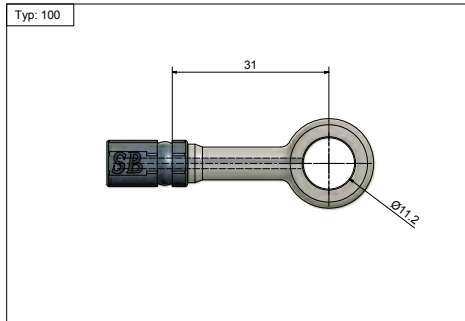

01 03 04 05 08 09 10 11 20 30

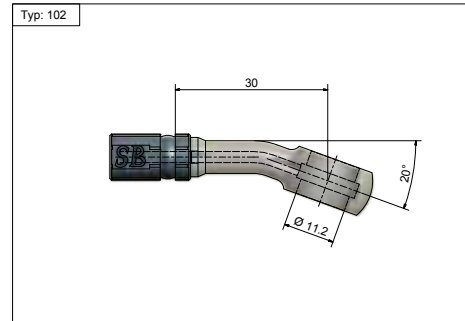

01 03 04 05 08 09 10 11 20 30

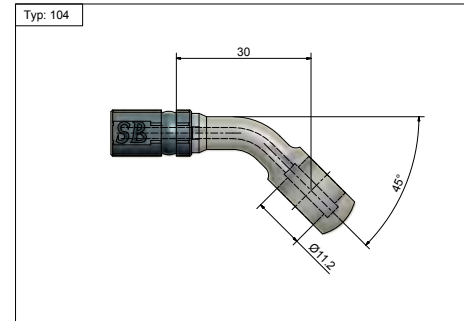

01 03 04 05 08 09 10 11 20 30

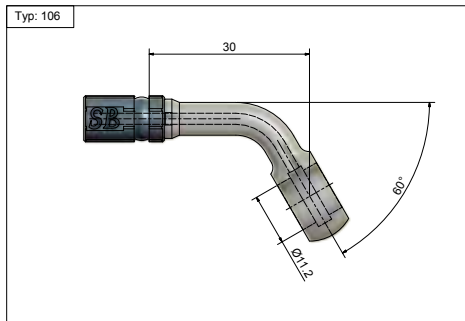

01 03 04 05 08 09 10 11 20 30

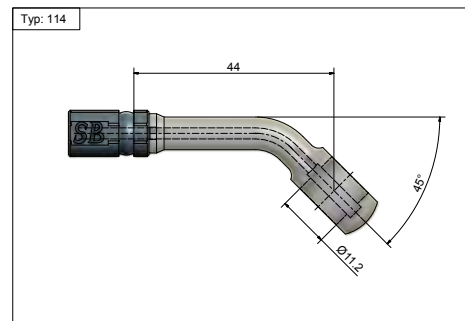

01 03 04 05 08 09 10 11 20 30

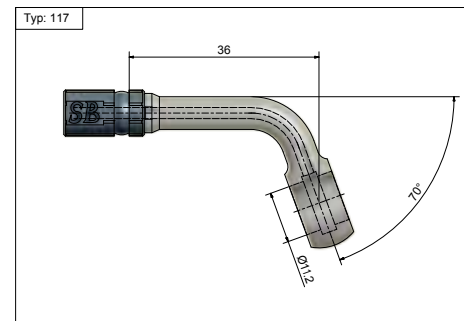

01 03 04 05 08 09 10 11 20 30

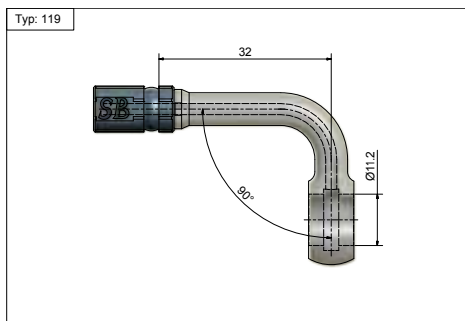

01 03 04 05 08 09 10 11 20 30

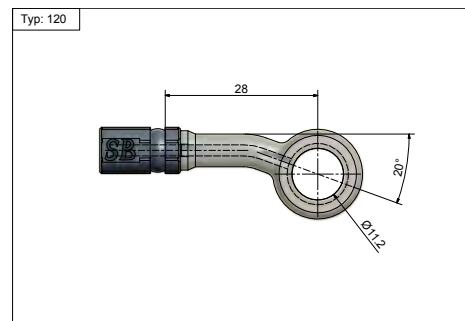

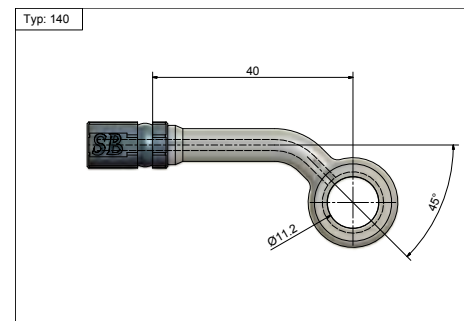

01 03 04 05 08 09 10 11 20 30



01 03 04 05 08 09 10 11 20 30

 **Unterstrichen = Teil in dieser Farbe verfügbar**
weitere Farben auf Anfrage
Underlined = part in this color available
other colors on request

-  01 = silber / silver
-  03 = blau / blue
-  04 = rot / red
-  05 = grün / green
-  08 = schwarz / black
-  09 = gold
-  10 = violett / violet
-  11 = anthrazit / anthracite
-  20 = verchromt / chrome-plated
-  30 = Edelstahl / stainless steel

Ringfittings 12,2mm
ring connectors 12,2mm

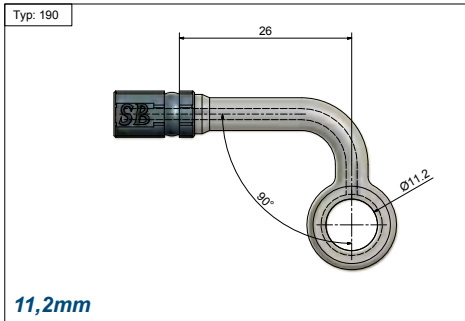

01 03 04 05 08 09 10 11 20 30

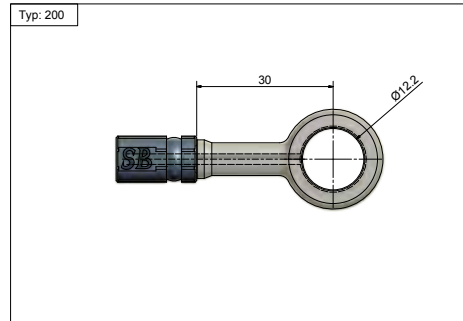

01 03 04 05 08 09 10 11 20 30

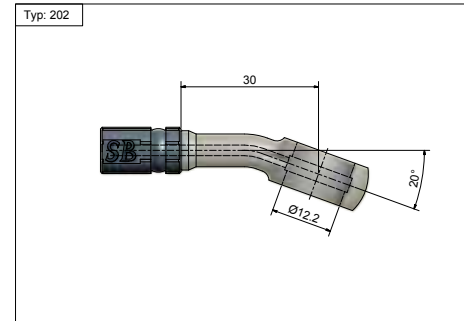

01 03 04 05 08 09 10 11 20 30

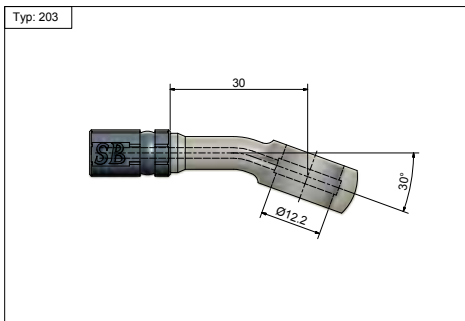

01 03 04 05 08 09 10 11 20 30

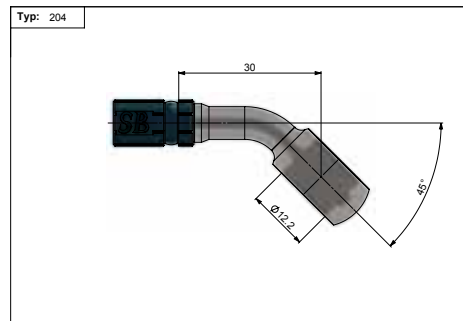

01 03 04 05 08 09 10 11 20 30

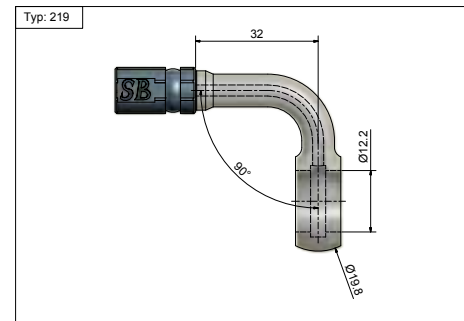

01 03 04 05 08 09 10 11 20 30

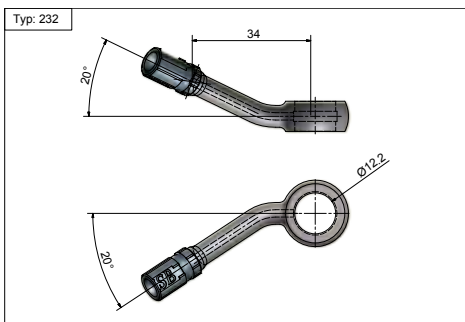

01 03 04 05 08 09 10 11 20 30

 **Unterstrichen = Teil in dieser Farbe verfügbar**
weitere Farben auf Anfrage
Underlined = part in this color available
other colors on request

- 01 = silber / silver
- 03 = blau / blue
- 04 = rot / red
- 05 = grün / green
- 08 = schwarz / black
- 09 = gold
- 10 = violett / violet
- 11 = anthrazit / anthracite
- 20 = verchromt / chrome-plated
- 30 = Edelstahl / stainless steel

Aussengewinde - fest
external thread - fixed

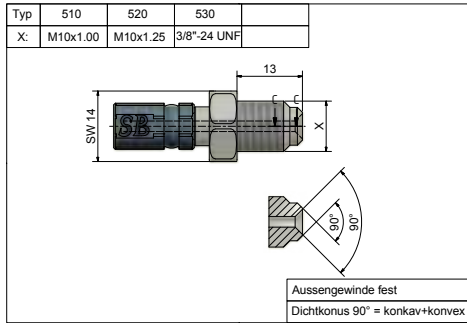

01 03 04 05 08 09 10 11 20 30

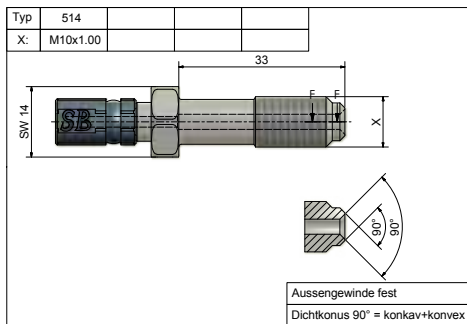

01 03 04 05 08 09 10 11 20 30

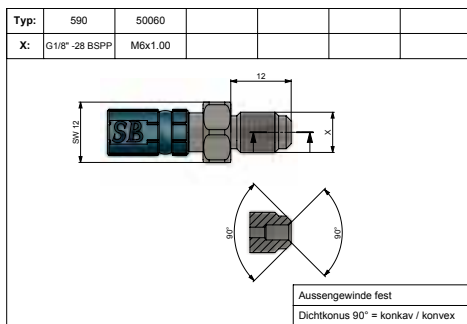

01 03 04 05 08 09 10 11 20 30

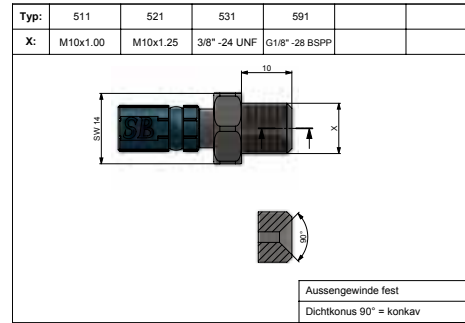

01 03 04 05 08 09 10 11 20 30

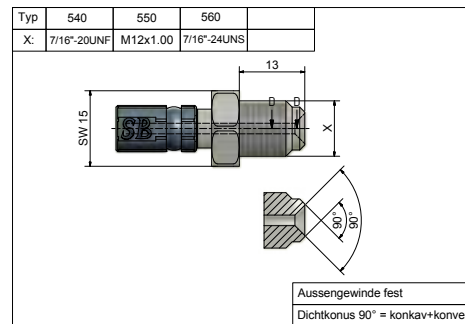

01 03 04 05 08 09 10 11 20 30

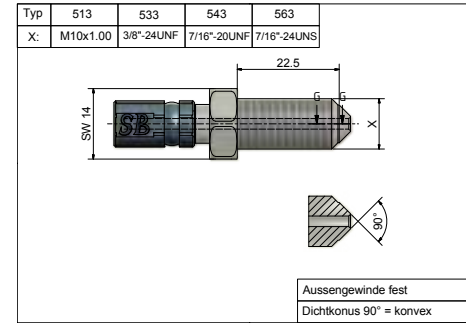

01 03 04 05 08 09 10 11 20 30

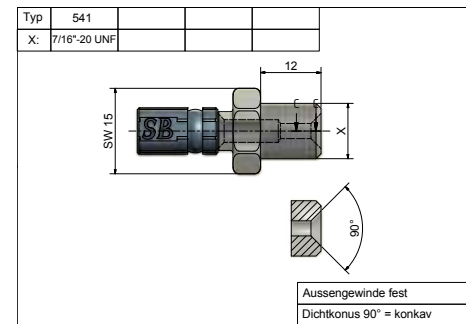

01 03 04 05 08 09 10 11 20 30

 **Unterstrichen = Teil in dieser
Farbe verfügbar**
weitere Farben auf Anfrage
**Underlined = part in this
color available**
other colors on request

- 01 = silber / silver
- 03 = blau / blue
- 04 = rot / red
- 05 = grün / green
- 08 = schwarz / black
- 09 = gold
- 10 = violett / violet
- 11 = anthrazit / anthracite
- 20 = verchromt / chrome-plated
- 30 = Edelstahl / stainless steel

Aussengewinde - lose external thread - swivel

Typ	9x8		
X:			

Winkelverteiler

01 03 04 05 08 09 10 11 20 30

Typ	412	422	432	442
X:	M10x1.00	M10x1.25	3/8"-24 UNF	7/16"-20 UNF

Aussengewinde beweglich
Dichtkonus 90° = konkav+konvex

01 03 04 05 08 09 10 11 20 30

Typ	417	427	437
X:	M10x1.00	M10x1.25	3/8"-24 UNF

Aussengewinde beweglich
Dichtkonus 90° = konkav+konvex

01 03 04 05 08 09 10 11 20 30

Typ	410	420	430
X:	M10x1.00	M10x1.25	3/8"-24 UNF

Aussengewinde beweglich
Dichtkonus 90° = konkav+konvex

01 03 04 05 08 09 10 11 20 30

Typ	413	423	433	443	453	463
X:	M10x1.00	M10x1.25	3/8"-24 UNF	7/16"-20 UNF SW 14	M12x1.00 SW 17	7/16"-24 UNS SW 14

Aussengewinde beweglich
Dichtkonus 90° = konvex

01 03 04 05 08 09 10 11 20 30

Typ	418	428	438
X:	M10x1.00	M10x1.25	3/8"-24 UNF

Aussengewinde beweglich
Dichtkonus 90° = konkav+konvex

01 03 04 05 08 09 10 11 20 30

Typ	411	421	431
X:	M10x1.00	M10x1.25	3/8"-24 UNF

Aussengewinde beweglich
Speziell für Kunifer

01 03 04 05 08 09 10 11 20 30

Typ	414	424	434
X:	M10x1.00	M10x1.25	3/8"-24 UNF

Aussengewinde beweglich
Dichtkonus 90° = konkav+konvex

01 03 04 05 08 09 10 11 20 30

Typ	419	429	439
X:	M10x1.00	M10x1.25	3/8"-24 UNF

Aussengewinde beweglich
Dichtkonus 90° = konkav+konvex

01 03 04 05 08 09 10 11 20 30

 **Unterstrichen = Teil in dieser
Farbe verfügbar**
weitere Farben auf Anfrage
*Underlined = part in this
color available*
other colors on request

- 01 = silber / silver
- 03 = blau / blue
- 04 = rot / red
- 05 = grün / green
- 08 = schwarz / black
- 09 = gold
- 10 = violett / violet
- 11 = anthrazit / anthracite
- 20 = verchromt / chrome-plated
- 30 = Edelstahl / stainless steel

Aussengewinde - lose

external thread - swivel

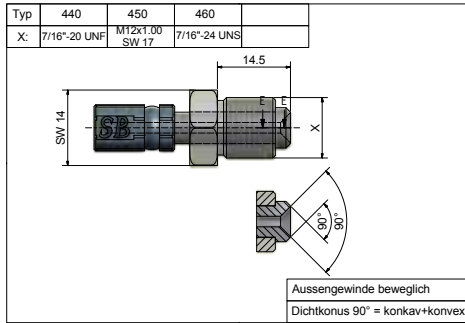

01 03 04 05 08 09 10 11 20 30

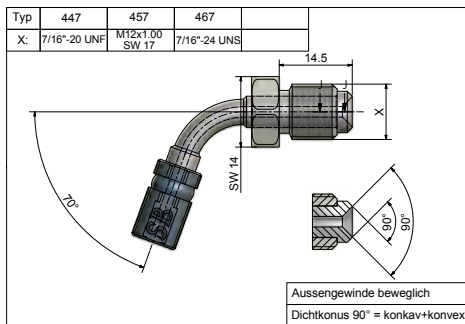

01 03 04 05 08 09 10 11 20 30

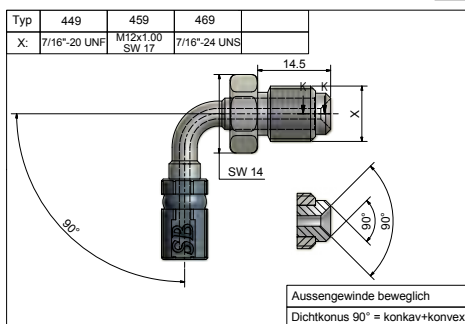

01 03 04 05 08 09 10 11 20 30

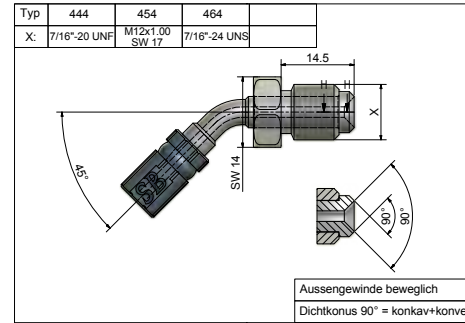

01 03 04 05 08 09 10 11 20 30

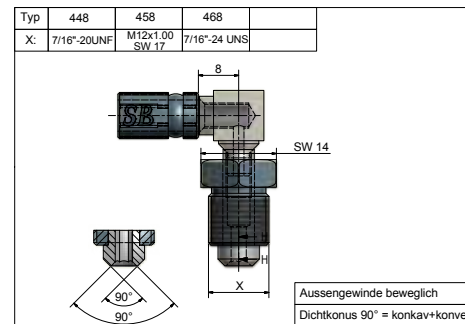

01 03 04 05 08 09 10 11 20 30

Innengewinde - fest

internal thread - fixed

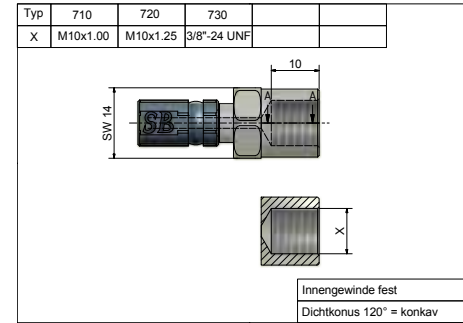

01 03 04 05 08 09 10 11 20 30

 **Unterstrichen = Teil in dieser
Farbe verfügbar**
weitere Farben auf Anfrage
**Underlined = part in this
color available**
other colors on request

- 01 = silber / silver
- 03 = blau / blue
- 04 = rot / red
- 05 = grün / green
- 08 = schwarz / black
- 09 = gold
- 10 = violett / violet
- 11 = anthrazit / anthracite
- 20 = verchromt / chrome-plated
- 30 = Edelstahl / stainless steel

Innengewinde - lose internal thread - swivel

Typ	610	620	630		
X	M10x1.00	M10x1.25	3/8"-24 UNF		

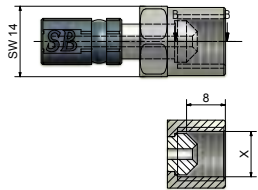

Innengewinde beweglich
Dichtkonus 90° = konvex

01	03	04	05	08	09	10	11	20	30
----	----	----	----	----	----	----	----	----	----

Typ	614	624	634		
X	M10x1.00	M10x1.25	3/8"-24 UNF		

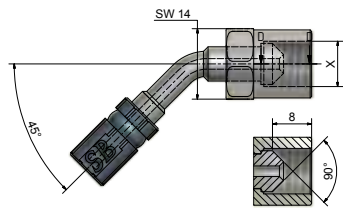

Innengewinde beweglich
Dichtkonus 90° = konvex

01	03	04	05	08	09	10	11	20	30
----	----	----	----	----	----	----	----	----	----

Typ	619	629	639		
X	M10x1.00	M10x1.25	3/8"-24 UNF		

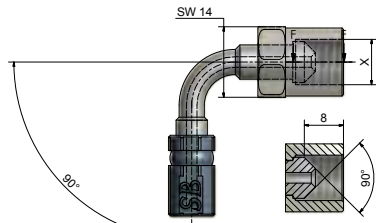

Innengewinde beweglich
Dichtkonus 90° = konvex

01	03	04	05	08	09	10	11	20	30
----	----	----	----	----	----	----	----	----	----

Typ	611	621	631		
X	M10x1.00	M10x1.25	3/8"-24 UNF		

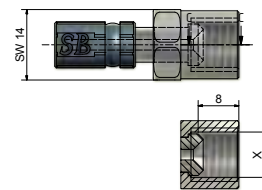

Innengewinde beweglich
Dichtkonus 90° = konvex-konkav

01	03	04	05	08	09	10	11	20	30
----	----	----	----	----	----	----	----	----	----

Typ	617	627	637		
X	M10x1.00	M10x1.25	3/8"-24 UNF		

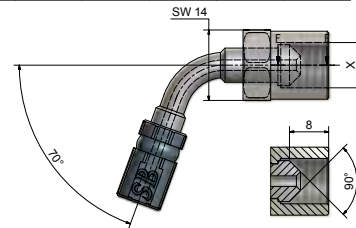

Innengewinde beweglich
Dichtkonus 90° = konvex

01	03	04	05	08	09	10	11	20	30
----	----	----	----	----	----	----	----	----	----

Typ	633				
X	3/8"-24 UNF				

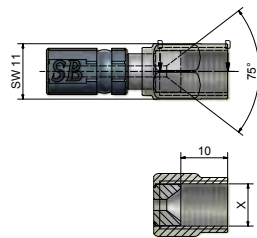

Innengewinde beweglich
Dichtkonus 75° = konkav

01	03	04	05	08	09	10	11	20	30
----	----	----	----	----	----	----	----	----	----

Typ	612	622	632		
X	M10x1.00	M10x1.25	3/8"-24 UNF		

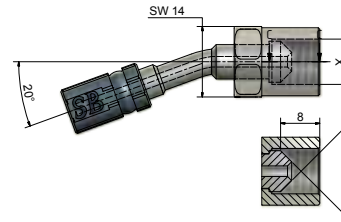

Innengewinde beweglich
Dichtkonus 90° = konvex

01	03	04	05	08	09	10	11	20	30
----	----	----	----	----	----	----	----	----	----

Typ	618	628	638		
X	M10x1.00	M10x1.25	3/8"-24 UNF		

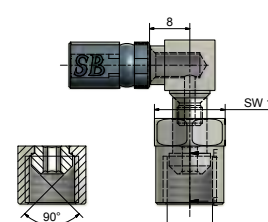

Innengewinde beweglich
Dichtkonus 90° = konvex

01	03	04	05	08	09	10	11	20	30
----	----	----	----	----	----	----	----	----	----

Typ	690				
X	G 1/8"				

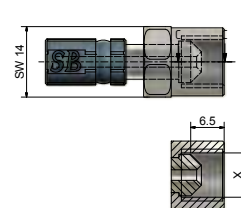

Innengewinde beweglich
Dichtkonus 90° = konvex

01	03	04	05	08	09	10	11	20	30
----	----	----	----	----	----	----	----	----	----

 **Unterstrichen = Teil in dieser
Farbe verfügbar**
weitere Farben auf Anfrage
**Underlined = part in this
color available**
other colors on request

- 01 = silber / silver
- 03 = blau / blue
- 04 = rot / red
- 05 = grün / green
- 08 = schwarz / black
- 09 = gold
- 10 = violett / violet
- 11 = anthrazit / anthracite
- 20 = verchromt / chrome-plated
- 30 = Edelstahl / stainless steel

Hohlschrauben

banjo bolts

Typ:	4040	4060		
X:	7/16"-20UNF	7/16"-24UNS		

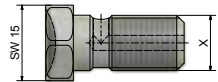

Hohlschraube

01 03 04 05 08 09 10 11 20 30

Typ:	4080	4082		
X:	M8x1.00	M8x1.25		

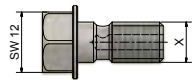

Hohlschraube

01 03 04 05 08 09 10 11 20 30

Typ:	4050	4008		
X:	M12x1.00	M12x1.5		

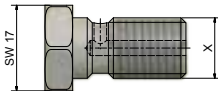

Hohlschraube

01 03 04 05 08 09 10 11 20 30

Typ:	40061	40060		
X:	M6x1.00	M6x1.00		

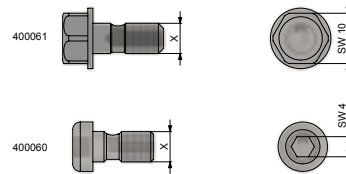

40060 mit Innensechskant
40061 mit aussensechskant

01 03 04 05 08 09 10 11 20 30

Typ:	4010	4020	4030	
X:	M10x1.00	M10x1.25	3/8"-24UNF	

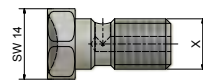

Hohlschraube

01 03 04 05 08 09 10 11 20 30

Typ:	5060			
X:	7/16"-24UNS			



double banjo bolts Doppelhohlschraube

01 03 04 05 08 09 10 11 20 30

Doppelhohlschrauben

double banjo bolts

Typ:	5080	5082		
X:	M8x1.00	M8x1.25		

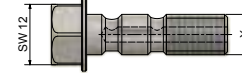

Doppelhohlschraube

01 03 04 05 08 09 10 11 20 30

Typ:	5010	5020	5030	
X:	M10x1.00	M10x1.25	3/8"-24UNF	



Doppelhohlschraube

01 03 04 05 08 09 10 11 20 30

Typ:	5008			
X:	M12x1.5			



Doppelhohlschraube

01 03 04 05 08 09 10 11 20 30

 **Unterstrichen = Teil in dieser
Farbe verfügbar**
weitere Farben auf Anfrage
**Underlined = part in this
color available**
other colors on request

- 01 = silber / silver
- 03 = blau / blue
- 04 = rot / red
- 05 = grün / green
- 08 = schwarz / black
- 09 = gold
- 10 = violett / violet
- 11 = anthrazit / anthracite
- 20 = verchromt / chrome-plated
- 30 = Edelstahl / stainless steel

Hohlschrauben - spezial

banjo bolts - special

Typ	4010010	4020010		
X	M10x1.00	M10x1.25		

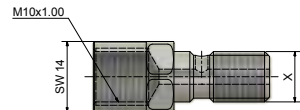

Hohlschraube mit Innengewinde

01	03	04	05	08	09	10	11	20	30
----	----	----	----	----	----	----	----	----	----

Typ	4061	4062		
X	M10x1.00 / M6	M10x1.25 / M6		

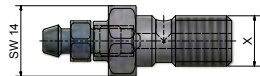

Hohlschraube mit Entlüfternippel

01	03	04	05	08	09	10	11	20	30
----	----	----	----	----	----	----	----	----	----

Typ	4210	4220	4230	
X	M10x1.00	M10x1.25	3/8"-24UNF	

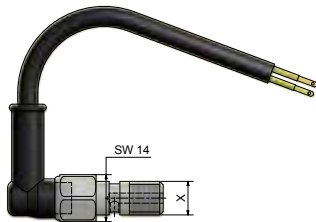

Hohlschraube mit Bremsdruckschalter

01	03	04	05	08	09	10	11	20	30
----	----	----	----	----	----	----	----	----	----

Doppelhohlschrauben - spezial

double banjo bolts - special

Typ	5061	5062		
X	M10x1.00 / M6	M10x1.25 / M6		

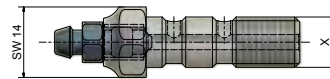

Doppelhohlschraube mit Entlüfternippel

01	03	04	05	08	09	10	11	20	30
----	----	----	----	----	----	----	----	----	----

Typ	5010010	5020010		
X	M10x1.00	M10x1.25		

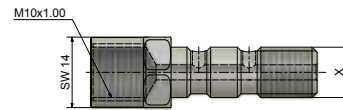

Doppelhohlschraube mit Innengewinde

01	03	04	05	08	09	10	11	20	30
----	----	----	----	----	----	----	----	----	----

Typ	5210	5220	5230	
X	M10x1.00	M10x1.25	3/8"-24UNF	

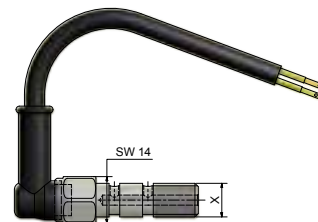

Doppelhohlschraube mit Bremsdruckschalter

01	03	04	05	08	09	10	11	20	30
----	----	----	----	----	----	----	----	----	----

Entlüfternippel / Bremslichtschalter

bleeder / brake light switch

Typ	2506			
X	M6			

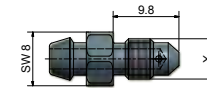

Entlüfternippel für Hohlschrauben

01	03	04	05	08	09	10	11	20	30
----	----	----	----	----	----	----	----	----	----

Typ	4110			
X	M10x1.00			

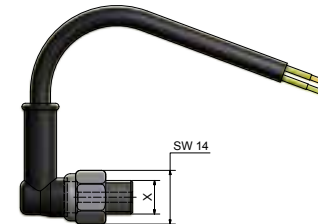

Bremsdruckschalter

01	03	04	05	08	09	10	11	20	30
----	----	----	----	----	----	----	----	----	----

 **Unterstrichen = Teil in dieser
Farbe verfügbar**
weitere Farben auf Anfrage
**Underlined = part in this
color available**
other colors on request

- 01 = silber / silver
- 03 = blau / blue
- 04 = rot / red
- 05 = grün / green
- 08 = schwarz / black
- 09 = gold
- 10 = violett / violet
- 11 = anthrazit / anthracite
- 20 = verchromt / chrome-plated
- 30 = Edelstahl / stainless steel

Verteiler 2-fach
2-way manifold

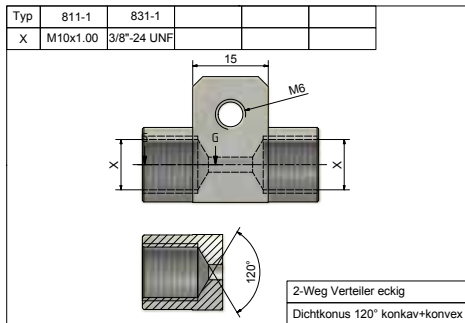

01 03 04 05 08 09 10 11 20 30

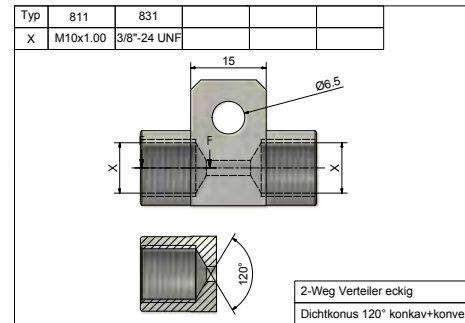

01 03 04 05 08 09 10 11 20 30

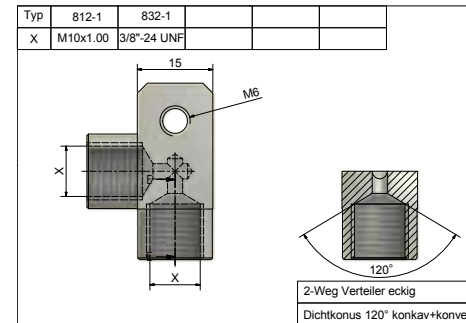

01 03 04 05 08 09 10 11 20 30

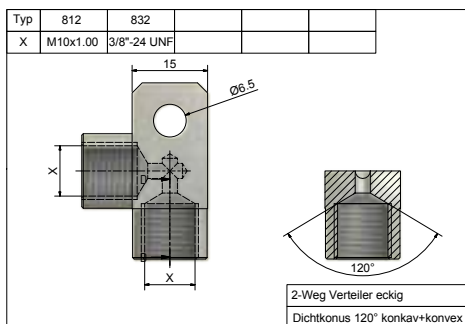

01 03 04 05 08 09 10 11 20 30

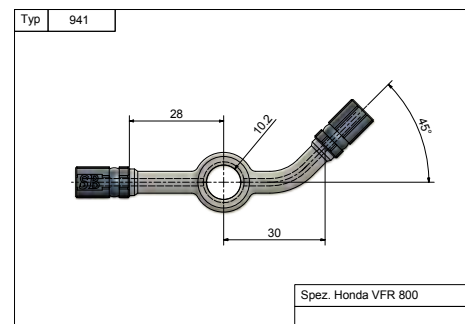

01 03 04 05 08 09 10 11 20 30

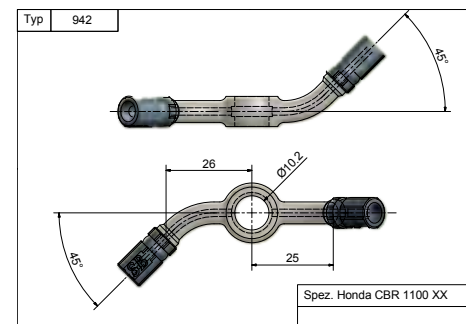

01 03 04 05 08 09 10 11 20 30

 **Unterstrichen = Teil in dieser
Farbe verfügbar**
weitere Farben auf Anfrage
*Underlined = part in this
color available*
other colors on request

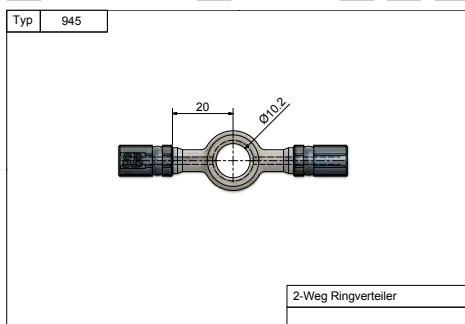

01 03 04 05 08 09 10 11 20 30

- 01 = silber / silver
- 03 = blau / blue
- 04 = rot / red
- 05 = grün / green
- 08 = schwarz / black
- 09 = gold
- 10 = violett / violet
- 11 = anthrazit / anthracite
- 20 = verchromt / chrome-plated
- 30 = Edelstahl / stainless steel

Verteiler 3-fach

3-way manifold

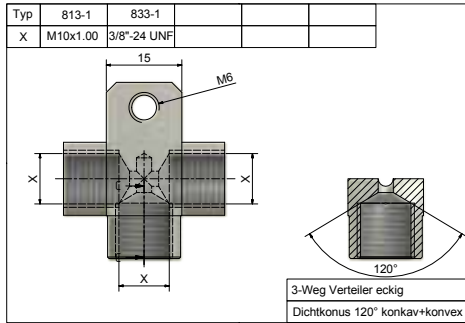

01 03 04 05 08 09 10 11 20 30

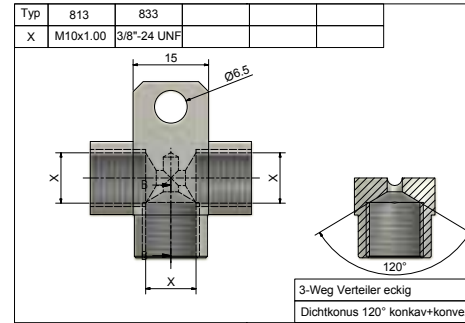

01 03 04 05 08 09 10 11 20 30

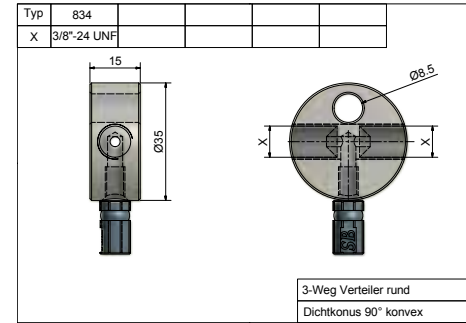

01 03 04 05 08 09 10 11 20 30

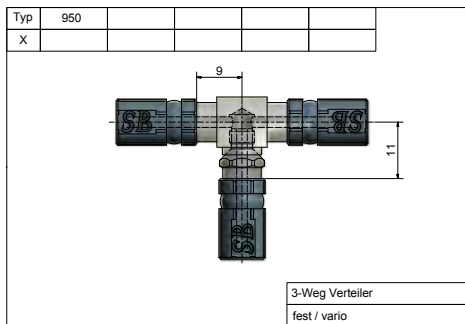

01 03 04 05 08 09 10 11 20 30

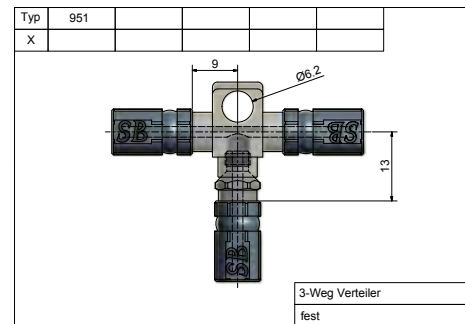

01 03 04 05 08 09 10 11 20 30

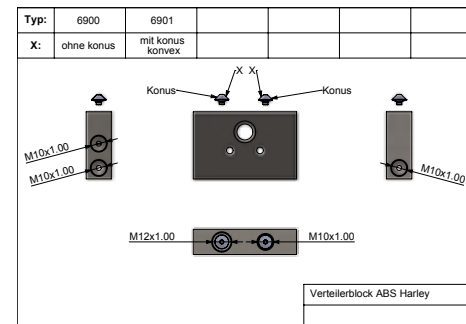

01 03 04 05 08 09 10 11 20 30

 **Unterstrichen = Teil in dieser
Farbe verfügbar**
weitere Farben auf Anfrage
*Underlined = part in this
color available*
other colors on request

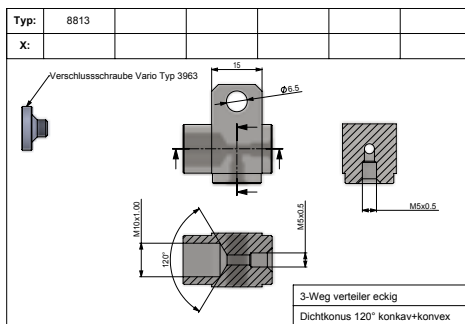

01 03 04 05 08 09 10 11 20 30

- 01 = silber / silver
- 03 = blau / blue
- 04 = rot / red
- 05 = grün / green
- 08 = schwarz / black
- 09 = gold
- 10 = violett / violet
- 11 = anthrazit / anthracite
- 20 = verchromt / chrome-plated
- 30 = Edelstahl / stainless steel

Doppelnippel - Adapter

twoside threaded fittings - adapter

Typ:	2515533	2521533	2511533	2531533		
X:	M10x1.5	M10x1.25	M10x1.00	3/8"-24 UNF		

Doppelnippel
Konus Dasch 3 konvex

01 03 04 05 08 09 10 11 20 30

Typ:	2531510	2591510				
X:	3/8"-24 UNF	G1/8"-28 BSPP				

Doppelnippel
Konus Dasch 3 konvex

01 03 04 05 08 09 10 11 20 30

Typ:	4710520	4710550	4720570	4750510		
X:	M10x1.25	M12x1.00	M10x1.25	M10x1.00		
Y:	M10x1.00	M10x1.00	M12x1.25	M12x1.00		

Messing-Adapter
innen / aussen

Typ:	4710710	4710720	4750710			
X:	M10x1.00	M10x1.00	M12x1.00			
Y:	M10x1.00	M10x1.25	M10x1.00			

Messing-Verbindungsstück
innen / innen

Verschiedenes

various

Typ:	010	085		008		
X:	Ø10	Ø8		Ø8		

Messing Oliven

Typ:	3963					
X:						

Verschlusschraube Vario

01 03 04 05 08 09 10 11 20 30

 **Unterstrichen = Teil in dieser
Farbe verfügbar**
weitere Farben auf Anfrage
*Underlined = part in this
color available*
other colors on request

- 01 = silber / silver
- 03 = blau / blue
- 04 = rot / red
- 05 = grün / green
- 08 = schwarz / black
- 09 = gold
- 10 = violett / violet
- 11 = anthrazit / anthracite
- 20 = verchromt / chrome-plated
- 30 = Edelstahl / stainless steel

Kupplungen

junctions

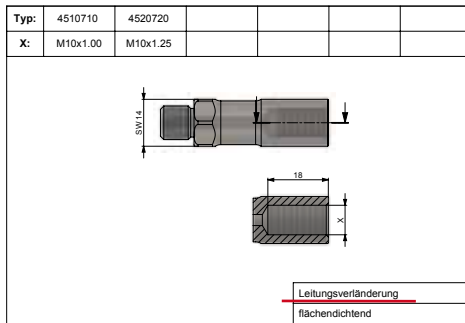

01 03 04 05 08 09 10 11 20 30

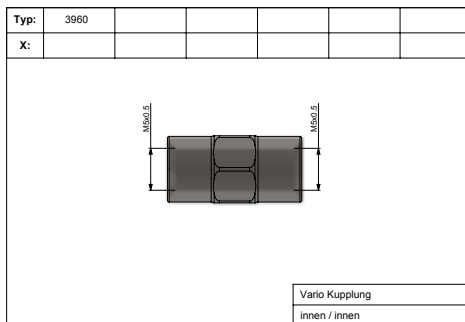

01 03 04 05 08 09 10 11 20 30

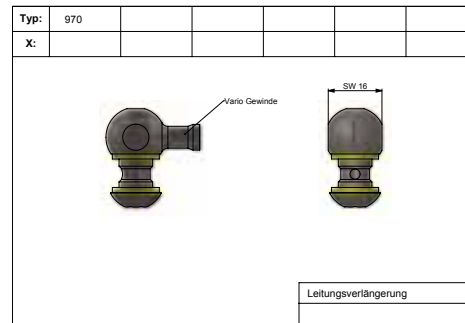

01 03 04 05 08 09 10 11 20 30

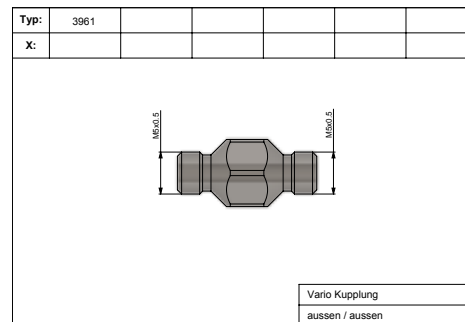

01 03 04 05 08 09 10 11 20 30



 **Unterstrichen = Teil in dieser
Farbe verfügbar**
weitere Farben auf Anfrage
**Underlined = part in this
color available**
other colors on request

- 01 = silber / silver
- 03 = blau / blue
- 04 = rot / red
- 05 = grün / green
- 08 = schwarz / black
- 09 = gold
- 10 = violett / violet
- 11 = anthrazit / anthracite
- 20 = verchromt / chrome-plated
- 30 = Edelstahl / stainless steel



Lieferprogramm Ringfittings / Delivery program ring connectors

Art.-Nr. art. no.	Typ type	Kugelhkopf Ø mm ball coupling Ø mm	Bohrung / Gewinde drilling / thread	Winkel / Steigung angle / flank lead	Länge in mm*** length in mm***	(z=1) festverpresst (z=1) crimped	(z=3) Vario (z=3) modular	Edelstahl stainless steel
Ringfittings standard Dash 4 i.D. Ø 3.5mm/ Ring connectors standard dash 4								
20-z0004030	00040	18	10.2	0°	39.5	X	-	X
20-z0024030	00240	18	10.2	20°	38	X	-	X
20-z0044030	00440	18	10.2	45°	34	X	-	X
20-z0174030	01740	18	10.2	70°	28	X	-	X
20-z0194030	01940	18	10.2	90°	21	X	-	X
Ringfittings standard Vario i.D. Ø 2.1mm/ Ring connectors standard vario								
20-z00030	000	18	10.2	0°	31	X	X	X
20-z10030	100	18	11.2	0°	31	X	X	X
20-z20030	200	20	12.2	0°	31	X	X	X
20-z00130	001	18	10.2	0° kurz	21	X	X	X
20-z10130	101	18	11.2	0° kurz	21	X	X	X
20-z00230	002	18	10.2	20°	31	X	X	X
20-z10230	102	18	11.2	20°	31	X	X	X
20-z20230	202	20	12.2	20°	31	X	-	X
20-z00330	003	18	10.2	30°	30	X	X	X
20-z10330	103	18	11.2	30°	30	X	-	X
20-z20330	203	20	12.2	30°	30	X	-	X
20-z00430	004	18	10.2	45°	27.5	X	X	X
20-z10430	104	18	11.2	45°	27.5	X	X	X
20-z20430	204	20	12.2	45°	27.5	X	X	X
20-z00630	006	18	10.2	60°	26	X	X	X
20-z10630	106	18	11.2	60°	26	X	-	X
20-z01730	017	18	10.2	70°	22	X	-	X
20-z11730	117	18	11.2	70°	22	X	-	X
20-z01930	019	18	10.2	90°	16.5	X	-	X
20-z11930	119	18	11.2	90°	16.5	X	X	X
20-z21930	219	20	12.2	90°	16.5	X	X	X
20-z02030	020	18	10.2	20°	30	X	X	X
20-z12030	120	18	11.2	30°	30	X	X	X
20-z02230	022	18	10.2	20°s/20°r	30	X	X	X
20-z12230	122	18	11.2	20°s/20°r	30	X	-	X
20-z02430	024	18	10.2	45°s/20°r	27	X	-	X
20-z02930	029	20	10.2	90°s/20°r	17	X	-	X
20-z22930	229	20	12.2	90°s/20°r	17	X	-	X
20-z03230	032	18	10.2	20°s/20°l	30	X	X	X
20-z13230	132	18	11.2	20°s/20°l	30	X	-	X
20-z03430	034	18	10.2	45°s/20°l	27	X	-	X
20-z03930	039	18	10.2	90°s/20°l	17	X	-	X
20-z23930	239	18	12.2	90°s/20°l	17	X	-	X
20-z09030	090	18	10.2	90°s	14	X	-	X
20-z16530	165	18	11.2	65°s	11	X	-	X

- l= Ringfittings nach links gebogen
ring connectors to the left bent
- r= Ringfittings nach rechts gebogen
ring connectors to the right bent
- s= Ringfittings seitlicher gebogen
ring connectors sideways bent



Vario / vario
Edelstahl / stainless steel



Festverpresst / crimped
Edelstahl / stainless steel

Bestellung / Art. Nr. Order / Art. no. code

Z= 1 (festverpresst) 1 (crimped)
Z= 3 (Vario) 3 (Vario)

Bestellungsmuster:
Order sample:
20 - 3 000 30

20 - Z . . . 30

Lieferprogramm Gewinde / Delivery program thread

Art.-Nr. art. no.	Typ type	Winkel / Steigung angle / flank lead	Bohrung / Gewinde drilling / thread	Gewindesteigung flank lead	Schlüsselweite wrench size	Länge Gewinde length thread	Länge Anschl.(mm) length fitting	(z=1) festverpresst (z=1) crimped	(z=3) Vario (z=3) modular	Edelstahl stainless steel
Aussengewinde - fest / external thread - fixed										
20-z51330	513	0°	M10	1.00	14	23	32	X	X	X
20-z51430	514	0°	M10	1.00	14	33	43	X	X	X
20-z53330	533	0°	3/8"	24UNF	14	23	32	X	X	X
20-z54030	540	0°	7/16"	20UNF	14	13	22	X	X	X
20-z54130	541	0°	7/16"	20UNF	14	11	20.5	X	X	X
20-z54330	543	0°	7/16"	20UNF	14	22.5	20.5	X	X	X
20-z54430	544	0°	7/16"	20UNF	15	13.5	42	X	-	X
20-z55430	554	0°	M12	1.00	15	25.5	40	X	-	X
20-z56030	560	0°	7/16"	24UNS	14	13	22	X	X	X
20-z56330	563	0°	7/16"	24UNS	14	22.5	28	X	-	X
Aussengewinde - lose / external thread - swivel										
20-z41030	410	0°	M10	1.00	11	15	24	X	X	X
20-z41130	411	für Kunifer	M10	1.00	11	13	17.5	-	-	X
20-z41230	412	20°	M10	1.00	11	15	24	X	-	X
20-z41330	413	30°	M10	1.00	11	15	40	X	-	X
20-z41430	414	45°	M10	1.00	11	15	40	X	-	X
20-z41730	417	70°	M10	1.00	11	15	38	X	-	X
20-z41830	418	90° ***	M10	1.00	11	15	16	X	X	X
20-z41930	419	90° ***	M10	1.00	11	15	15	X	-	X
20-z42030	420	0°	M10	1.25	11	15	26	X	X	X
20-z42130	421	für Kunifer	M10	1.25	11	13	17.5	-	-	X
20-z42230	422	20°	M10	1.25	11	15	0	X	-	X
20-z42330	423	30°	M10	1.25	11	15	40	ST*	-	X
20-z42430	424	45°	M10	1.25	11	15	38	X	-	X
20-z42730	427	70°	M10	1.25	11	15	38	X	-	X
20-z42830	428	90° ***	M10	1.25	11	15	16	X	X	X
20-z42930	429	90° ***	M10	1.25	11	15	15	X	-	X
20-z43030	430	0°	3/8"	24UNF	11	15	26	X	X	X
20-z43130	431	für Kunifer	3/8"	24UNF	11	13	17.5	-	-	X
20-z43230	432	20°	3/8"	24UNF	11	15	40	X	-	X
20-z43330	433	30°	3/8"	24UNF	11	15	40	ST*	-	X
20-z43430	434	45°	3/8"	24UNF	11	15	38	X	-	X
20-z43730	437	70°	3/8"	24UNF	11	15	38	X	-	X
20-z43830	438	90° ***	3/8"	24UNF	11	15	30	X	X	X
20-z43930	439	90° ***	3/8"	24UNF	11	15	15	X	-	X
20-z44030	440	0°	7/16"	20UNF	12	15	24	X	X	X
20-z44330	443	30°	7/16"	20UNF	12	15	40	ST*	-	X
20-z44430	444	45°	7/16"	20UNF	12	15	38	X	-	X

ST* Keine Lagerware: Sonderteile werden auf Bestellung produziert.
Bitte längere Lieferzeiten einkalkulieren.
ST* Not in stock.
Special parts are made on order.
Please be aware of extended delivery times.

*** Edelstahlanschlüsse können in der Länge variieren
*** Stainless steel connectors may vary in length

Bestellung / Art. Nr. Order / Art. no. code

Z= 1 (festverpresst) 1 (crimped)
Z= 3 (Vario) 3 (Vario)

Bestellungsmuster: Order sample:
20 - 3 410 30

20 - z . . . 30



410



419



410

Lieferprogramm Gewinde / Delivery program thread

Art.-Nr. art. no.	Typ type	Winkel / Steigung angle / flank lead	Bohrung / Gewinde drilling / thread	Gewindesteigung flank lead	Schlüsselweite wrench size	Länge Gewinde length thread	Länge Anschl. (mm) length fitting	(z=1) festverpresst (z=1) crimped	(z=3) Vario (z=3) modular	Edelstahl stainless steel
Aussengewinde - lose / external thread - swivel										
20-z44730	447	70°	7/16"	20UNF	12	15	38	X	-	X
20-z44830	448	90°	7/16"	20UNF	12	15	30	-	X	X
20-z44930	449	90°	7/16"	20UNF	12	15	15	X	-	X
20-z45030	450	0°	M12	1.00	12	15	24	X	X	X
20-z45330	453	30°	M12	1.00	12	15	40	X	-	X
20-z45430	454	45°	M12	1.00	12	15	38	X	-	X
20-z45730	457	70°	M12	1.00	12	15	38	X	-	X
20-z45830	458	90° ***	M12	1.00	12	15	30	X	X	X
20-z45930	459	90° ***	M12	1.00	12	15	20	X	-	X
20-z46030	460	0°	7/16"	24UNF	12	15	24	X	X	X
20-z46330	463	30°	7/16"	24UNS	12	15	40	X	-	X
20-z46430	464	45°	7/16"	24UNS	12	15	38	X	-	X
20-z46730	467	70°	7/16"	24UNS	12	15	38	X	-	X
20-z46830	468	90°	7/16"	24UNS	12	15	30	-	X	X
20-z46930	469	90°	7/16"	24UNS	12	15	15	X	-	X
Innengewinde - fest / internal thread - fixed										
20-z71130	711	0°	M10	1.00	17	10	30	X	X	X
20-z72130	721	0°	M10	1.25	17	10	30	X	-	X
20-z76130	761	0°	7/16"	24UNS	17	10	30	X	-	X
20-z71230	712	0°	M10	1.00	15	8.5	23	X	-	X
20-z71330	713	0°	M10	1.00	17	9.7	30	X	X	X
20-z72330	723	0°	M10	1.25	17	9.7	30	X	X	X
20-z73330	733	0°	3/8"	24UNF	17	9.7	30	X	X	X
20-z71430	714	0°	M10	1.00	17	10	30	X	X	X
20-z71530	715	0°	M10	1.00	17	10	23	X	X	X
20-z70530	705	0°	M10	1.5	17	10	23	X	-	X
20-z71630	716	0°	M10	1.00	17	5.7	23	X	X	X
20-z71730	717	0°	M10	1.00	19	7.5	28	X	X	X
20-z71830	718	0°	M10	1.00	17	8.5	23	X	-	X
20-z71930	719	0°	M10	1.00	14	10	23	X	X	X
20-z75130	751	0°	M12	1.00	19	10	26	X	-	X
20-z78230	782	0°	M10	1.00	17	10	30	X	X	X
20-z78330	783	0°	M10	1.00	17	10	23	X	-	X
20-z78930	789	0°	M10	1.00	17	10	30	X	X	X
20-z72930	729	0°	M10	1.25	17	10	30	X	X	X
20-z73930	739	0°	3/8"	24UNF	17	10	30	X	X	X
20-z74930	749	0°	7/16"	24UNF	17	10	30	X	X	X
20-z76930	769	0°	7/16"	24UNS	17	10	30	X	X	X

ST* Keine Lagerware: Sonderteile werden auf Bestellung produziert.
Bitte längere Lieferzeiten einkalkulieren.
ST* Not in stock.
Special parts are made on order.
Please be aware of extended delivery times.

*** Edelstahlanschlüsse können in der Länge variieren
*** Stainless steel connectors may vary in length

Bestellung / Art. Nr. Order / Art. no. code

Z= 1 (festverpresst) 1 (crimped)

Bestellungsmuster: Order sample:

Z= 3 (Vario) 3 (Vario)

20 - 1 450 30

20 - z . . . 30



714



711



782



789

Bestellung / Art. Nr. Order / Art. no. code

Z= 1 (festverpresst) 1 (crimped)
Z= 3 (Vario) 3 (Vario)

Bestellungsmuster: Order sample:
20 - 3 630 30

20 - z . . . 30



619



6105

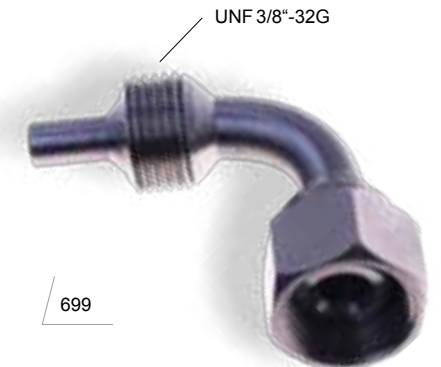

699

UNF 3/8"-32G

UNF 3/8"-32G

Lieferprogramm Gewinde / Delivery program thread

Art.-Nr. art. no.	Typ type	Winkel / Steigung angle / flank lead	Bohrung / Gewinde drilling / thread	Gewindesteigung flank lead	Schlüsselweite wrench size	Länge Gewinde length thread	Länge Anschl. (mm) length fitting	(z=1) festverpresst (z=1) crimped	(z=3) Vario (z=3) modular	Edelstahl stainless steel
Innengewinde - lose / internal thread - swivel										
20-z61030	610	0°	M10	1.00	14	8	19	X	X	X
20-z61230	612	20°	M10	1.00	14	8	38	X	-	X
20-z61330	613	0°	M10	1.00	19	8	24	X	X	X
20-z61430	614	45°	M10	1.00	14	8	38	X	-	X
20-z61530	615	0°	M10	1.50	15	8	26	X	X	X
20-z61730	617	70°	M10	1.00	19	8	22	X	-	X
20-z61830	618	90°	M10	1.00	14	9	16	-	X	X
20-z61930	619	90°	M10	1.00	14	8	16	X	-	X
20-z62030	620	0°	M10	1.25	14	8	15	X	X	X
20-z62230	622	20°	M10	1.25	14	8	38	X	-	X
20-z62430	624	45°	M10	1.25	14	8	38	X	-	X
20-z62730	627	70°	M10	1.25	14	8	22	X	-	X
20-z62830	628	90°	M10	1.25	14	9	16	-	X	X
20-z62930	629	90°	M10	1.25	14	8	16	X	-	X
20-z63030	630	0°	3/8"	24UNF	14	8	15	X	X	X
20-z63230	632	20°	3/8"	24UNF	14	8	38	X	-	X
20-z63330	633	0°	3/8"	24UNF	11	10	19	X	X	X
20-z63430	634	45°	3/8"	24UNF	14	8	38	X	-	X
20-z63730	637	70°	3/8"	24UNF	14	8	22	X	-	X
20-z63830	638	90°	3/8"	24UNF	14	8	16	-	X	X
20-z63930	639	90°	3/8"	24UNF	14	8	16	-	X	X
20-z69030	690	0°	G 1/8"	28UNF	14	8	19	X	X	X
20-z610530	6105	0°	M10	1.5	15	8	17	X	X	X

Ringfittige standard Dash 4
ring connectors standard dash 4

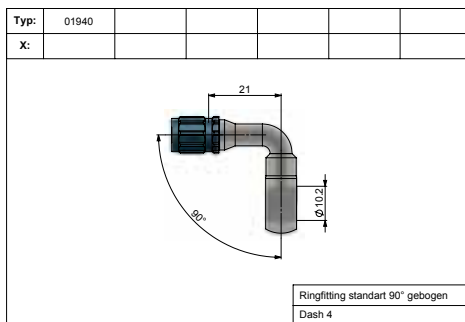
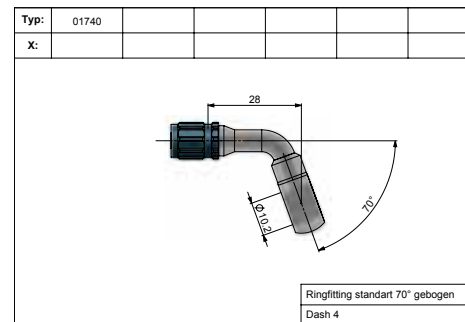
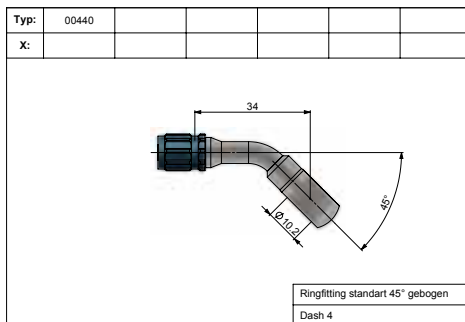
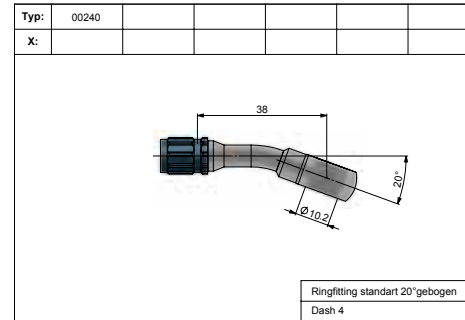
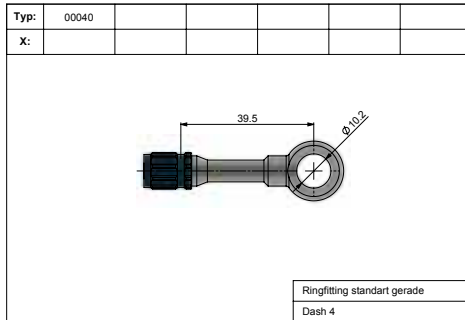

Ringfittige standard Vario
ring connectors standard vario

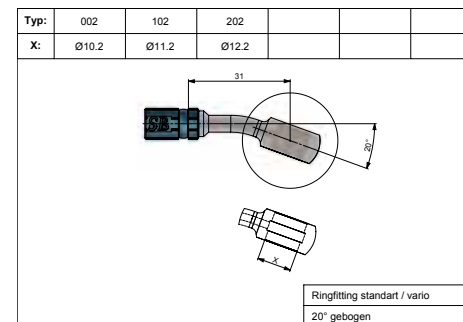
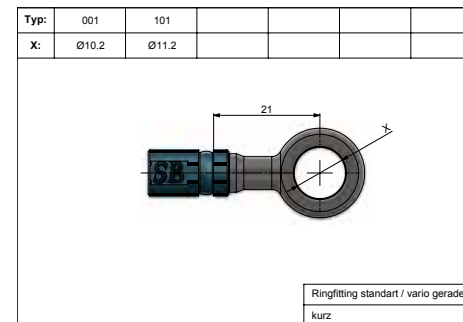
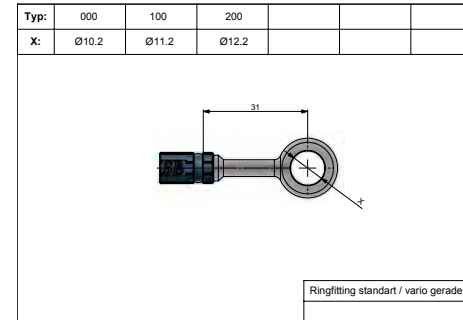

Ringfittige standard Vario
ring connectors standard vario

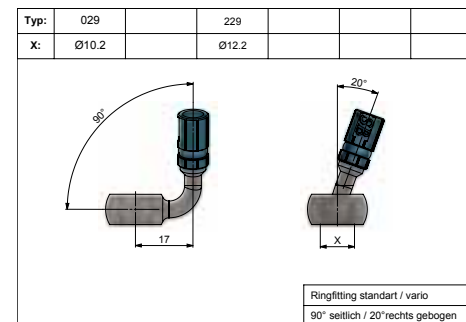
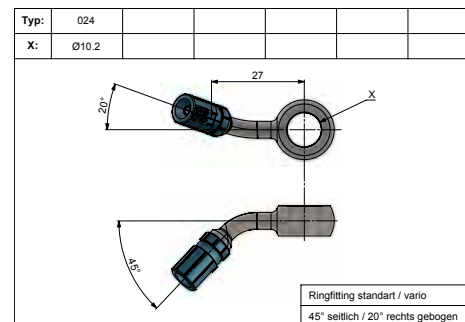
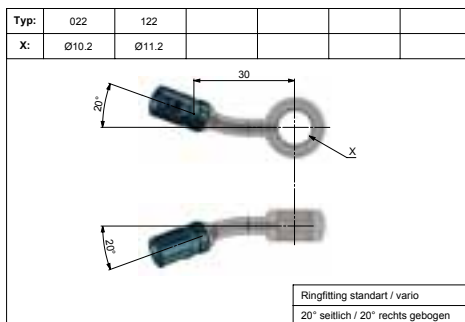
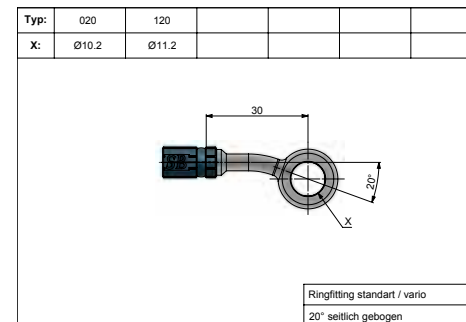
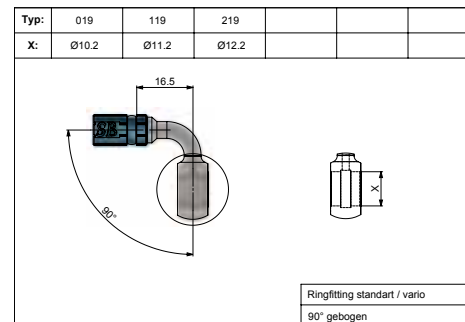
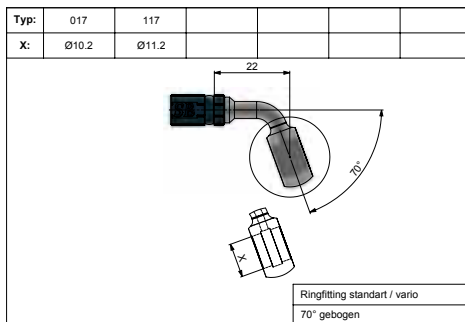
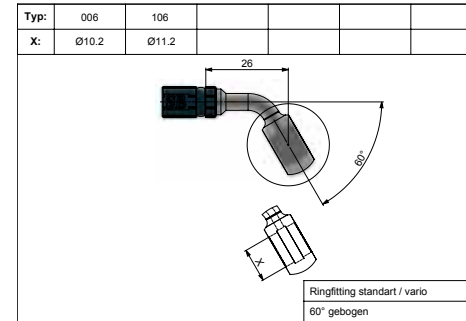
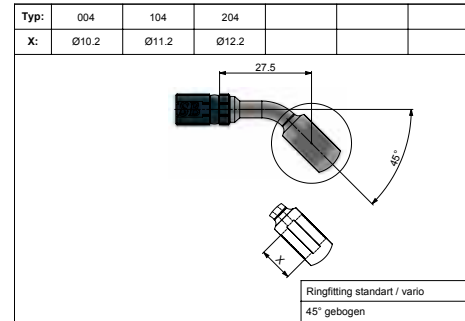
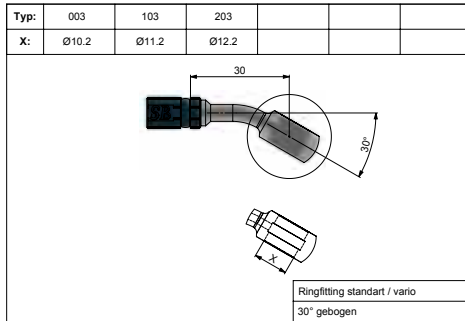

Ringfittige standard Vario

ring connectors standard vario

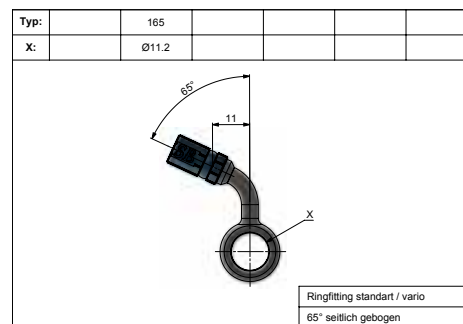
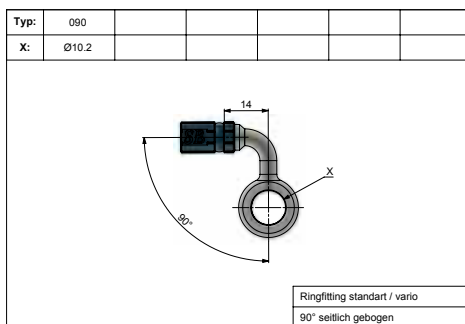
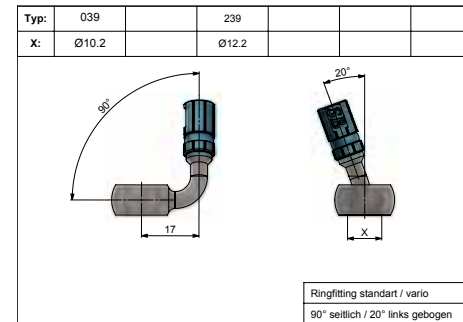
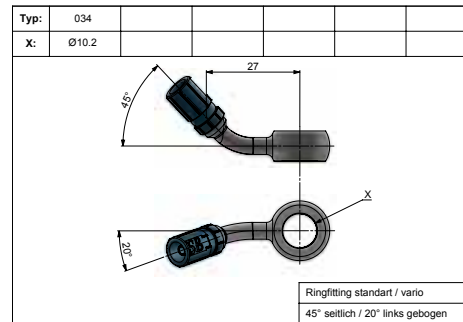
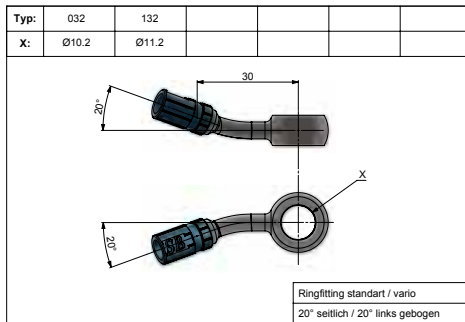

Aussengewinde - fest
external thread - fixed

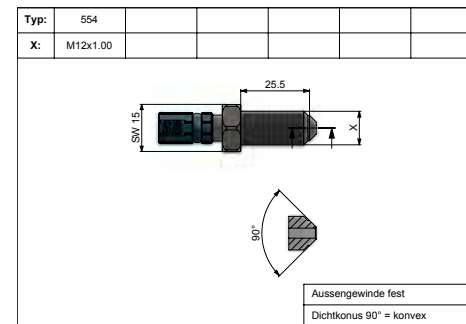
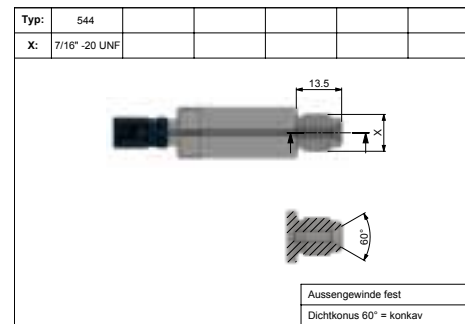
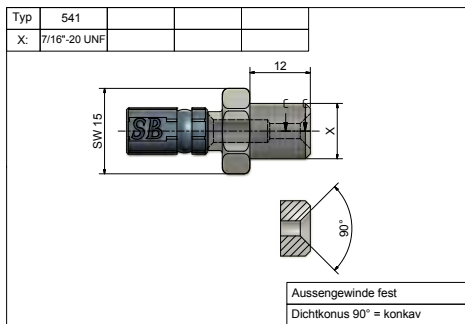
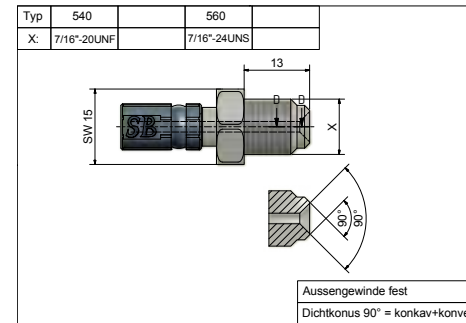
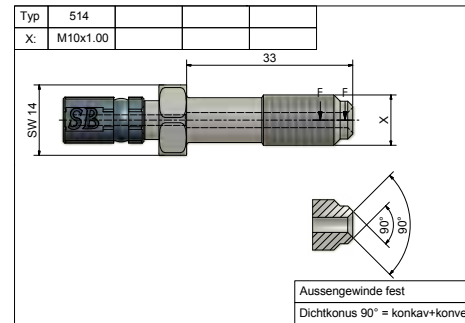
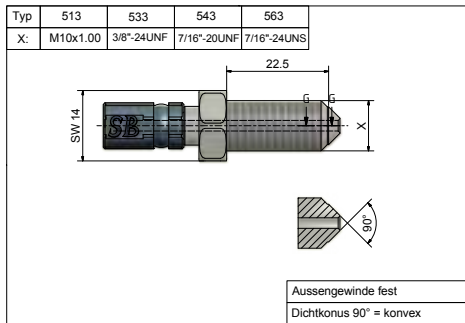

Aussengewinde - lose
external thread - swivel

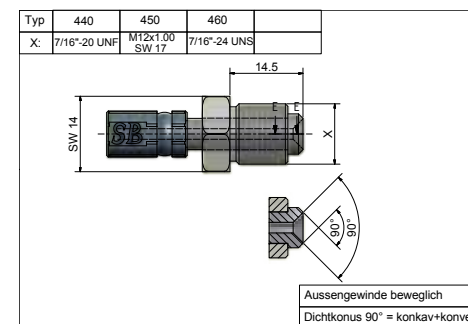
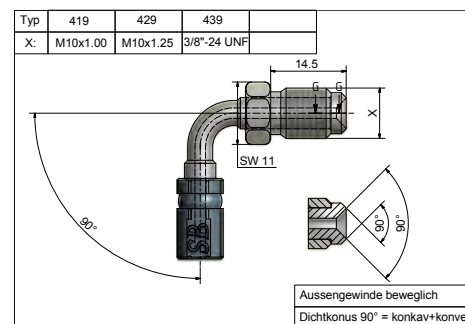
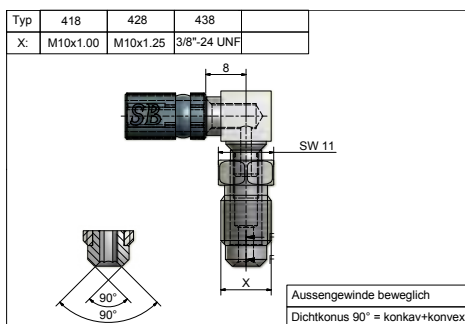
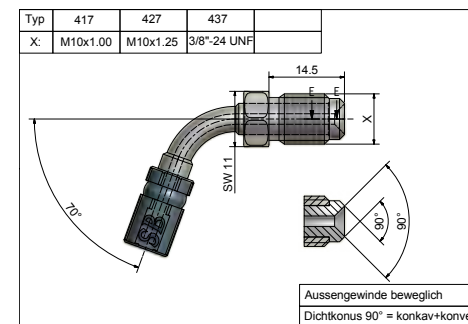
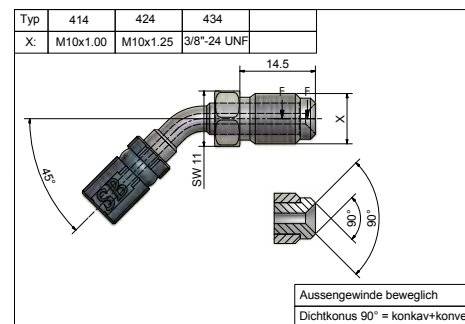
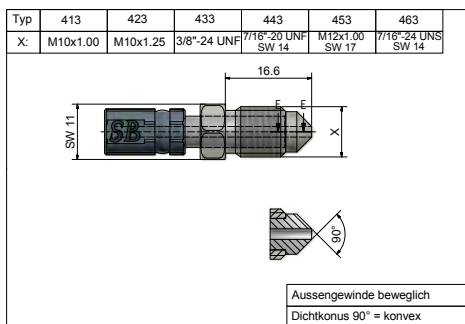
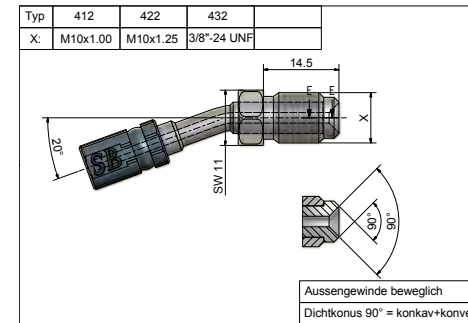
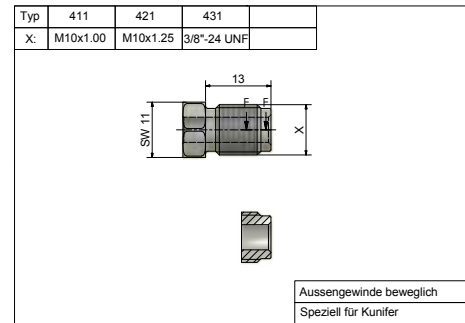
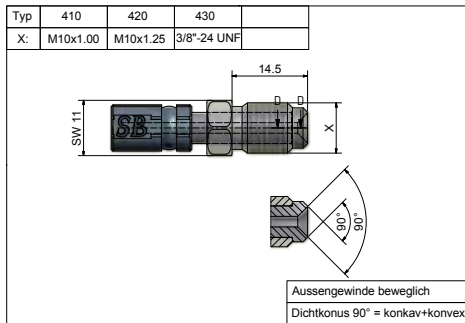

Aussengewinde - lose

external thread - swivel

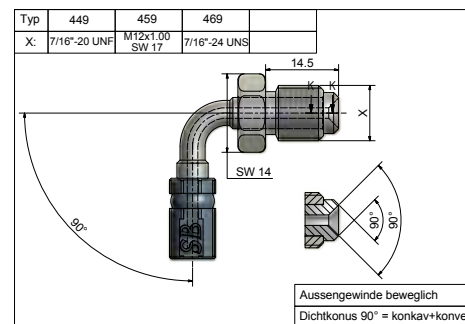
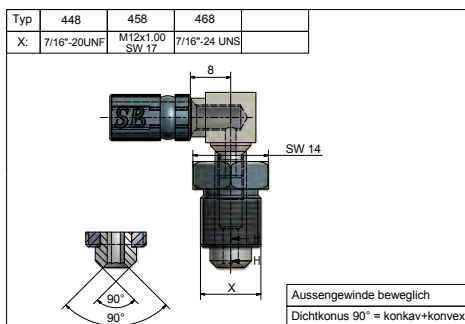
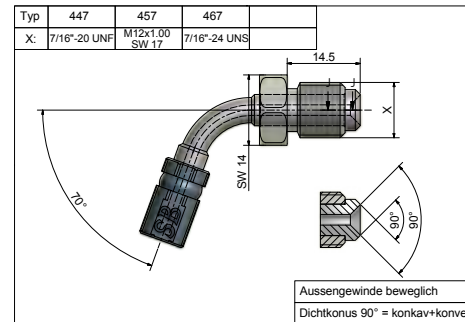
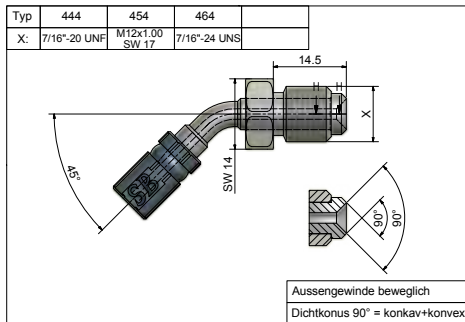

Innengewinde - fest
internal thread - fixed

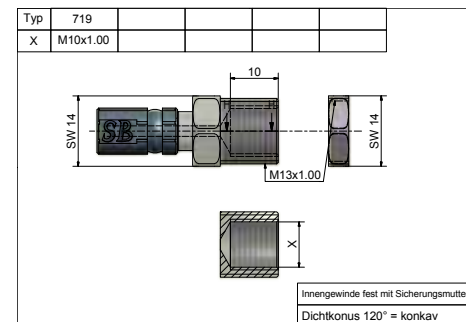
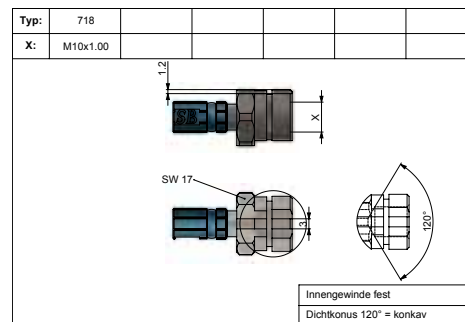
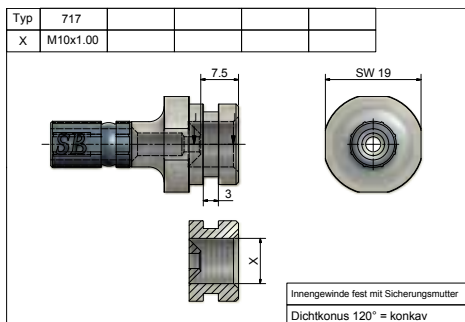
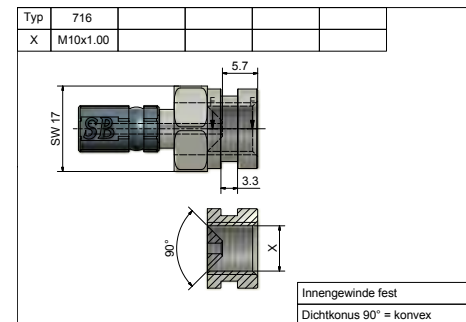
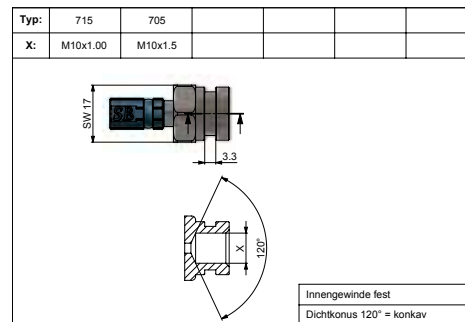
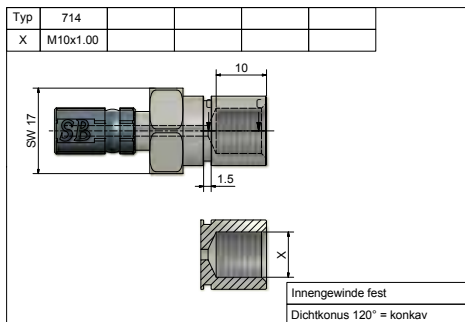
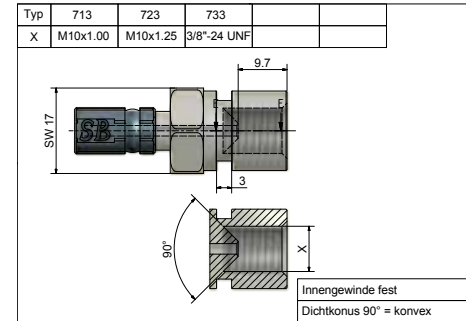
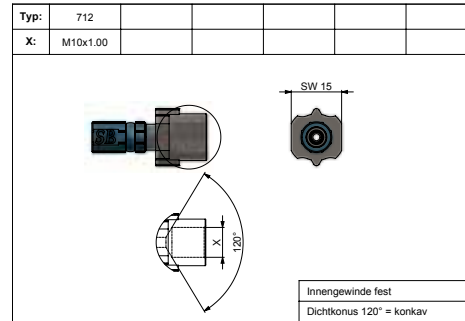
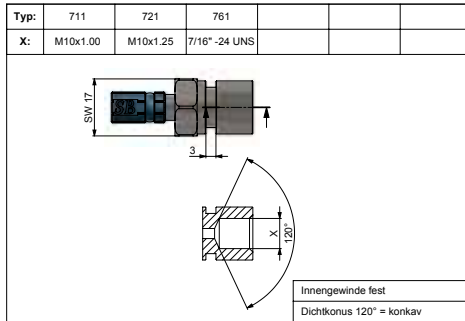

Innengewinde - fest internal thread - fixed

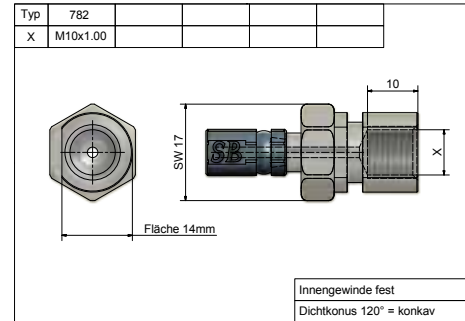
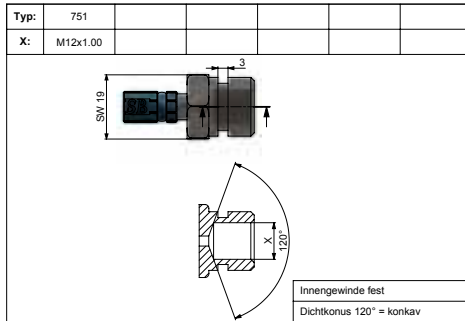

Innengewinde - lose internal thread - swivel

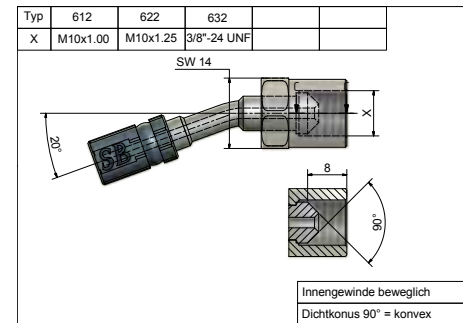
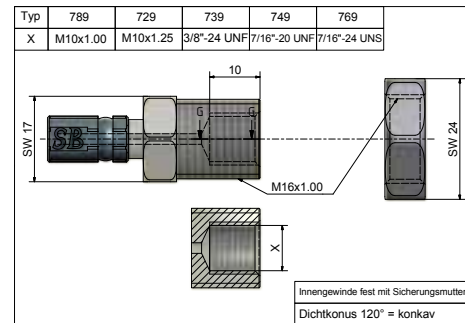
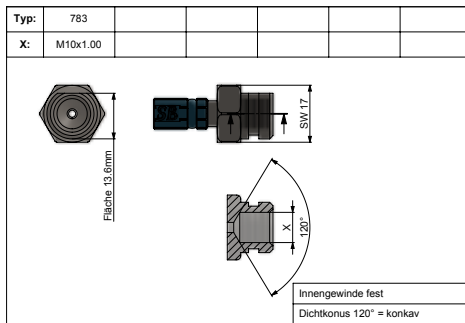
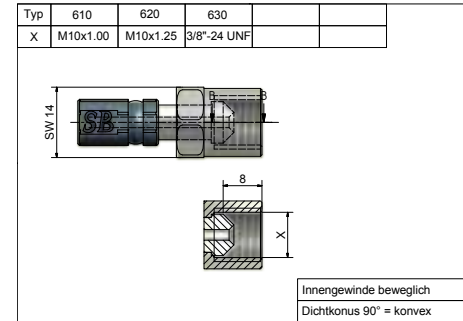

Innengewinde - lose
internal thread - swivel

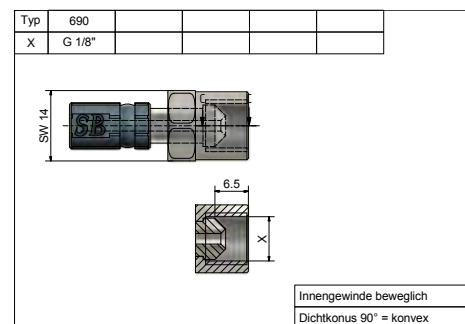
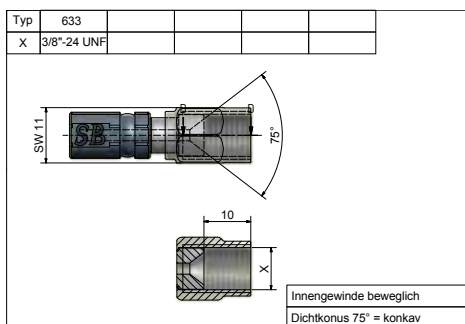
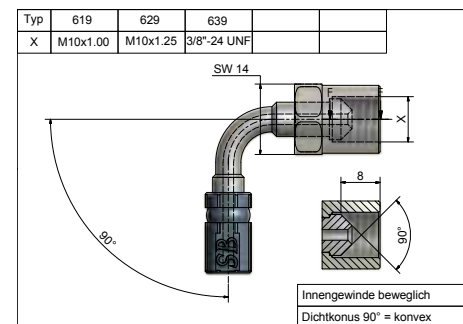
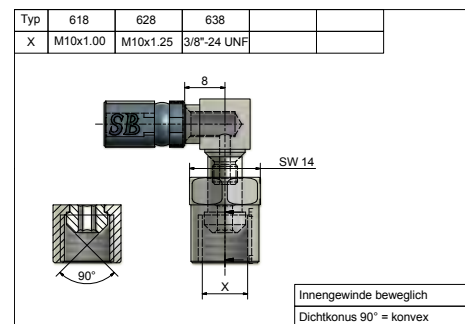
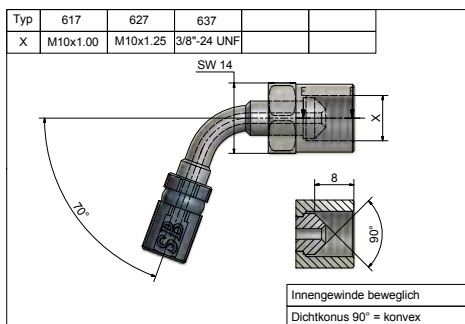
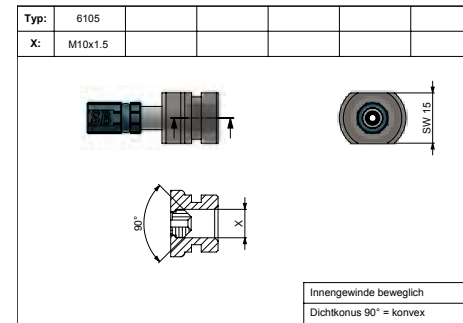
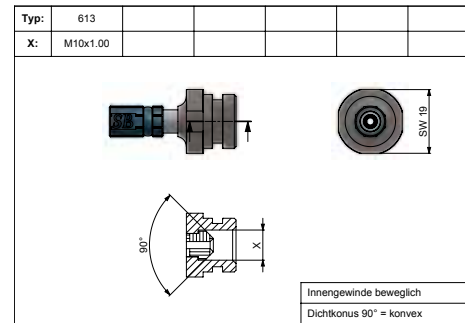
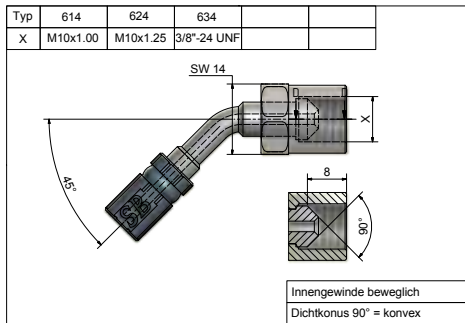

Speed Brakes - Schweizer Eigenproduktion

Die Schweizer Firma SB Speed Brakes AG ist seit 1994 in Pratteln bei Basel ansässig. Gegründet wurde Speed Brakes von den Inhabern der Firma Motacc Suisse GmbH, welche schon seit 1989 auf dem Schweizer Motorradmarkt tätig ist.

Das Ziel der Firma Speed Brakes ist es, erstklassige Komponenten für Stahlflexbremsleitungen zu produzieren und zu vertreiben. Durch eigene Fertigung auf modernsten CNC-Fräs- und Drehmaschinen konnte dieses Ziel schnell erreicht werden. Das Sortiment an Bremsleitungskomponenten wird ständig erweitert und den Anforderungen des Marktes angepasst.

Dieses Wissen versetzt die Firma Speed Brakes in die Lage, Sonderanfertigungen und neue innovative Produkte in kürzester Zeit zu produzieren.

Speed Brakes ist einer der wenigen Hersteller von Bremsleitungskomponenten, der alle diese Teile selbst fertigt und somit vollen Einfluss auf das Endprodukt hat.

Die Fertigung und Lagerhaltung umfasst mehrere tausend Bremsleitungskomponenten für die unterschiedlichsten Fahrzeugmodelle. Jede Bremsleitung ist ein Unikat und wird in hoher Schweizer Qualität hergestellt.

Die Firma entwickelt und realisiert innovative Komponenten für den Einsatzbereich von PTFE-Hochdruckschläuchen für die Chemie und Industrie.



Edelstahl

Seit 2008 produziert Speed Brakes auch Edelstahlanschlüsse für härteste Einsätze im Rallye- und Motocrossbereich. Das Programm an Autokomponenten wird ebenfalls laufend erweitert. Somit ist die Firma Speed Brakes auch ein starker Partner im Bereich Vierradfahrzeuge.

Vario System

Das Vario System von Speed Brakes mit dem schlanken Design hat sich zu einem beliebten Produkt für Fachhändler entwickelt. Durch das interessante Set-Angebot, bietet es dem Händler höchste Flexibilität bei minimalen Lagerkosten. Das Vario System hat sich weltweit als hochwertiges, schraubbares Bremsleitungssystem durchgesetzt und wird mittlerweile auch kopiert. Von Speed Brakes erhalten Sie das Original.

Hoher Qualitätsstandard

Speed Brakes Bremsleitungen wurden bereits 1995 nach der weltweit anerkannten US-Prüfnorm FMVSS 106 geprüft und freigegeben. Das Leitungsprogramm entspricht den geltenden Vorschriften RL93/14/EWG, ECE R78.02, ECE R13 und 71/320EWG, was mit der EG-ABE, bzw. dem zugrundeliegenden TÜV-Teilegutachten bestätigt ist. Die in diesem Verfahren durchgeführten Prüfungen sind den Schweizerischen Vorschriften gleichwertig (VTS Art. 30 ABS. 1 Bst d). Die Austauschbremsleitungen sind für ABS-Fahrzeuge zugelassen (sowohl für Motorräder als auch für Autos/Quads).

Eloxalverfahren

Unsere Aluminiumbremsanschlüsse werden mit einem speziellen Eloxalverfahren in der Schweiz behandelt. Die Farben sind lichtecht, hochglänzend und korrosions-beständig.

Vertriebsstruktur

Die Speed Brakes Produkte werden durch die Firmen Motacc Schweiz und Deutschland an den Fachhandel vertrieben. Die Firma Speed Brakes beliefert seit der Gründung Großhändler und Erstausrüster weltweit.

Pratteln, im August 2016



Speed Brakes - Swiss Made

The Swiss company SB Speed Brakes AG has been located at Pratteln near Basel since 1994. The founders were also owners of the company Motacc Suisse GmbH, which has been successfully in the motorbike business since 1989.

Speed Brakes has been aiming to develop, produce and distribute first class components of stainless steel brake lines. Using up to date CNC machining centers in the owned work, this target was reached rapidly. The product assortment of brake line components will be developed on an ongoing basis, fulfilling the needs of the customers.

The accumulated knowledge enables Speed Brakes to develop and produce special parts and innovative solutions in short term and in short time to market.

Speed Brakes is one of the few manufacturers of brake line components, which manufacture the whole product range by themselves and that are so able to fully shape the design and quality of the delivered parts.

Several thousand brake line components for a wide range of use and vehicles are produced and in stock. Each manufactured brake line is unique and assembled in highest Swiss Quality.

Further on, Speed Brakes develops and manufactures innovative components for PTFE-high pressure hoses for different industries such as chemistry and mechanical engineering.

Stainless steel

Since 2008 Speed Brakes has been manufacturing stainless steel fittings for heavy use like for rallye race cars and for motorcross race motorbikes.

The range of car brake line components will be expanded continuously. Thus, Speed Brakes will remain a strong partner for the car industry.

Vario system

The slim designed and flexible Speed Brakes Vario System is a favored tool set for specialized dealers around the world. It offers high flexibility at low stock cost. The screwable high quality Vario System has won the recognition of its users and gets copied by competitors. Speed Brakes offers the original Vario System.

High Quality

Since 1995 the Speed Brakes brake lines has been certified in compliance with the globally recognized US standard FMVSS 106. The product range meets the current standards RL93/14/EWG, ECE R78.02, ECE R13 and 71/320EWG, what is stated in the EG-ABE and the with the respective underlying "TÜV-Teilgutachten". These procedures and be testing are equivalent and conform to the Swiss law (VTS Art. 30 ABS. 1 Bst d). The brake lines are approved for vehicles using antilock brake systems (ABS) too - for motorbikes, cars and quads.

Anodic Treatment

Speed Brakes aluminium fittings are especially anodic treated in Switzerland. The anodized parts are high gloss finished and the colors are resistant to light and corrosion.

Distribution

The products of Speed Brakes are distributed by the companies Motacc (Suisse) GmbH and Motacc Deutschland GmbH to motorbike retailers.

Since the start, the company Speed Brakes has been supplying wholesalers and OEM worldwide.

Pratteln, August 2016





Variokofferset mit Halterung
Vario kit with holder



Variokofferset / Art.-Nr. 95-175000
Vario kit / art. no. 95-175000



Bremsleitungshalterung / Art.-Nr. 95-170000
Brake line holder / art. no. 95-170000

Bremsleitungen / Brake lines





Hersteller / Manufacturer

SB Speed Brakes AG
Muttenerstrasse 119
CH-4133 MuttENZ
Schweiz

Telefon: +41 (0) 61 826 96 29
Fax: +41 61 (0) 826 96 25
www.speedbrakes.ch
info@speedbrakes.ch



Vertrieb / Distribution

Schweiz

Motacc (Suisse) GmbH
Muttenerstrasse 119
CH-4133 MuttENZ
Schweiz

Telefon: +41 (0) 61 826 96 26
Fax: +41 61 (0) 826 96 25
www.motacc.ch
info@motacc.ch

Vertrieb / Distribution

Deutschland - Europa

Motacc Deutschland GmbH
Siemensstrasse 5
D-79331 Teningen-Nimburg
Deutschland

Telefon: +49 (0) 7663 9429945
Fax: +49 (0) 7663 9429946
www.motacc.de
info@motacc.de