

MOTACC®

EXPERTENWISSEN SEIT 30 JAHREN

Die drei Firmen arbeiten seit rund dreissig Jahren zusammen und werden mittlerweile wie eine Familie wahrgenommen.

Sie kombinieren ihr Expertenwissen für Motorrad- und Auto-Zubehörteile. Viele Teile oder Komponenten werden in Deutschland oder in der Schweiz auf eigenen CNC-Fertigungsmaschinen in höchster Qualität hergestellt, geprüft und zugelassen.

Das Angebot wird laufend den sich wandelnden Bedürfnissen angepasst. Neben den Eigenprodukten wird den Motorradfachgeschäften eine breite Palette an Handelsprodukten namhafter Hersteller angeboten.

SB Speed Brakes AG – Swiss Made

Die Firma Speed Brakes ist Spezialistin in der Herstellung von Stahlflex-Bremseleitungen für Motorräder, Autos und Fahrräder – als Originalaustauschteile für Bremseleitungen aus Gummi.

Sukzessive kamen weitere Komponenten für Motorrad- und PKW-Bremssysteme hinzu – wie Stahlrohrbremseleitungen, Speedbleeder (Schnellentlüfter), Werkzeuge für das Bördeln und Biegen von Bremsrohren, Bremsflüssigkeitsbehälter, Bremslichtschalter, Leitungsverteiler, Spezialkomponenten und weiteres mehr.

Neben den festverpressten Bremseleitungsanschlüssen entwickelte Speed Brakes als Hersteller das „Vario-System“, welches den unschlagbaren Vorteil bietet, in schlanker Bauart Konusverschraubungen mit 100 % Dichtheit sicherzustellen. Unterschiedlichste Bremseleitungs-Komponenten können damit flexibel kombiniert und verbaut werden.

Die Teile werden auf modernen CNC-Maschinen im Betrieb in Pratteln bei Basel gefertigt. Speed Brakes ist bekannt für die Umsetzung innovativer Weiterentwicklungen im Bremseleitungs-bereich und hat – als Hersteller – für spezielle Fragestellungen passende Lösungsvorschläge bereit. Die langjährige Erfahrung im Bremseleitungs-engineering macht Speed Brakes zum vertrauenswürdigen internationalen Lieferanten für Motorradhändler, Motorradgrosshändler sowie Fahrzeugteilehersteller und Fahrzeughersteller.

Motacc GmbH (Schweiz und Deutschland)

Seit rund 30 Jahren vertreibt die Firma Motacc Suisse GmbH Verschleissteile von Herstellern in Erstausrüsterqualität an die Motorradhändler der Schweiz. Aufgrund der wachsenden Expertise und Fähigkeiten wurden bei Motacc immer mehr auch eigene Artikel entwickelt und hergestellt. Kurze Zeit nach der Gründung der Motacc Suisse GmbH wurde die Motacc Deutschland GmbH gegründet, welche den Vertrieb der eigenen Artikel und der Handelsprodukte für Deutschland und für den gesamten Euro-Raum übernahm und ausbaute.

Motacc ist neben Handelsware stark auf die Fertigung von Superbike-Umbauten, Lenkerspiegeln, Lenkergewichten, Bremsflüssigkeitsbehältern, Spiegelabdeckungen sowie Brems- und Kupplungshebel spezialisiert. Mit dem Easy-Mounting-System bietet Motacc ein breites Programm an, Superbike-Umbauten einfach und schnell auf bestehende Originalvorbauten zu montieren.

Seit Jahren ist Motacc bei Motorradhändlern ein zuverlässiger Vertrauenspartner.

MFW GmbH – Made in Germany

MFW wurde im Jahre 1988 gegründet und produziert alle Motorradteile auf eigenen CNC Dreh- und Fräsmaschinen in Teningen, Deutschland. Das Motto lautet: „Für jeden Biker die ideale Position auf seinem Bike!“

Begonnen hat alles mit Fußrasten, welche auch heute noch zum Kerngeschäft gehören.

Die Originalfußrasten werden durch ein MFW-Gelenk und eine MFW-Raste ersetzt.

Mittlerweile gibt es 11 verschiedene Fußrasten-Typen in 12 verschiedene Farben. Das Programm wird ständig erweitert, inklusive verstellbare Variogelenke in Verbindung mit verschiedenen Typen von Varioplatten. Die Anwendung reicht von Off-Road, über Touring bis Racing.

Innovative Brems- und Kupplungshebel, verschiedenste Lenkergewichte, Höher- und Tieferlegungen, aus dem Vol-len gefräste Spiegel... Dies ist nur ein kleiner Auszug aus der großen Palette des MFW-Angebots.

Für viele Motorradfahrer sind inzwischen die Spiegelgläser mit dem asphärischem Bereich zur Verhinderung des toten Winkels ein Muss.

MFW liefert an den Fachhandel und an Importeure weltweit und ist regelmäßig auf den großen Motorradmessen Europas als Aussteller vertreten.

Weitere Informationen finden Sie unter:
For more information visit us at:



www.motacc.com
www.speedbrakes.ch
www.mfw-wolf.de

EXPERT KNOW HOW FOR 30 YEARS

The three companies have been working together for thirty years now. They accumulate their expert know how for motorbike and car parts for the aftermarket. A lot of the parts are manufactured on own CNC-machines in Germany or Switzerland. High quality and legal approval are granted. The range of products will be adapted to the needs of the markets on an ongoing basis. In addition, parts of well-known brands are traded.

SB Speed Brakes AG – Swiss Made

Speed Brakes is specialized in manufacturing stainless steel brake lines for motorbikes and cars in the aftermarket. In general the brake lines are used to replace rubber brake lines.

Over the years, additional parts and components have been developed and launched such as steel tube brake lines, speed bleeder, tools for bending and flaring of brake line tubes, brake fluid reservoirs, brake light switches, brake line distributors, special parts and much more.

Next to crimped fittings, Speed Brakes as manufacturer developed the screw-on „vario system“ with the advantages of slim construction and 100 % leak proof screwing. Various parts of the brake line range can be mounted flexibly combined with the “vario system”.

All the parts are manufactured on up to date CNC-machines in the plant in Pratteln close to Basel. Speed Brakes is well known for the development of innovative and out of the box solutions for brake lines and brake systems. Speed Brakes has been a trustworthy supplier to motorbike workshops, wholesalers as well as manufacturers of motorbikes and vehicles for years.

Motacc Ltd (Switzerland and Germany)

Motacc Suisse Ltd has been distributor for spare and wear parts in OEM quality for bike dealers and workshops in Switzerland over the last 30 years.

With its growing expertise, Motacc has started to develop and manufacture own branded parts.

Soon after the start of Motacc Suisse Ltd, Motacc Germany Ltd was founded and has been distributing the range of products in Germany and all over Europe since.

Besides spare parts, Motacc is specialist for Superbike conversion, handlebar mirrors and weights, brake fluid reservoirs, mirror covers and for levers of brakes and clutches to name some.

The Motacc Easy-Mounting-System helps with a wide range of parts to change the bike from original into superbike style easily: It is mounted directly on the original top yoke of the bike.

Motorbike dealers and workshop have placed their continued trust in Motacc for years.

MFW GmbH – Made in Germany

MFW was founded in 1988 and manufactures all motorbike parts on CNC-machines in the plant in Teningen, Germany. The slogan goes: „The ideal position on the bike – for every biker!“.

It all started with foot rests, which still are core business of MFW. The original foot rests get replaced by MFW hinges and MFW footpegs. Today, 11 types of footpegs in 12 colors are manufactured. The range of products gets extended continuously; including adjustable vario hinges on different types of vario plates. The footpeg range covers off-road, touring and racing purpose.

Innovative brake and clutch levers, versatile handlebar weights, jack up and lowering kits, as well as high value mirrors are only an extract of the wide range of MFW parts.

A lot of bikers like MFW safer view mirror to eliminate dangerous blind spots.

MFW is supplier for retailers and distributors worldwide. Meet MFW at the important motorbike shows in Europe.

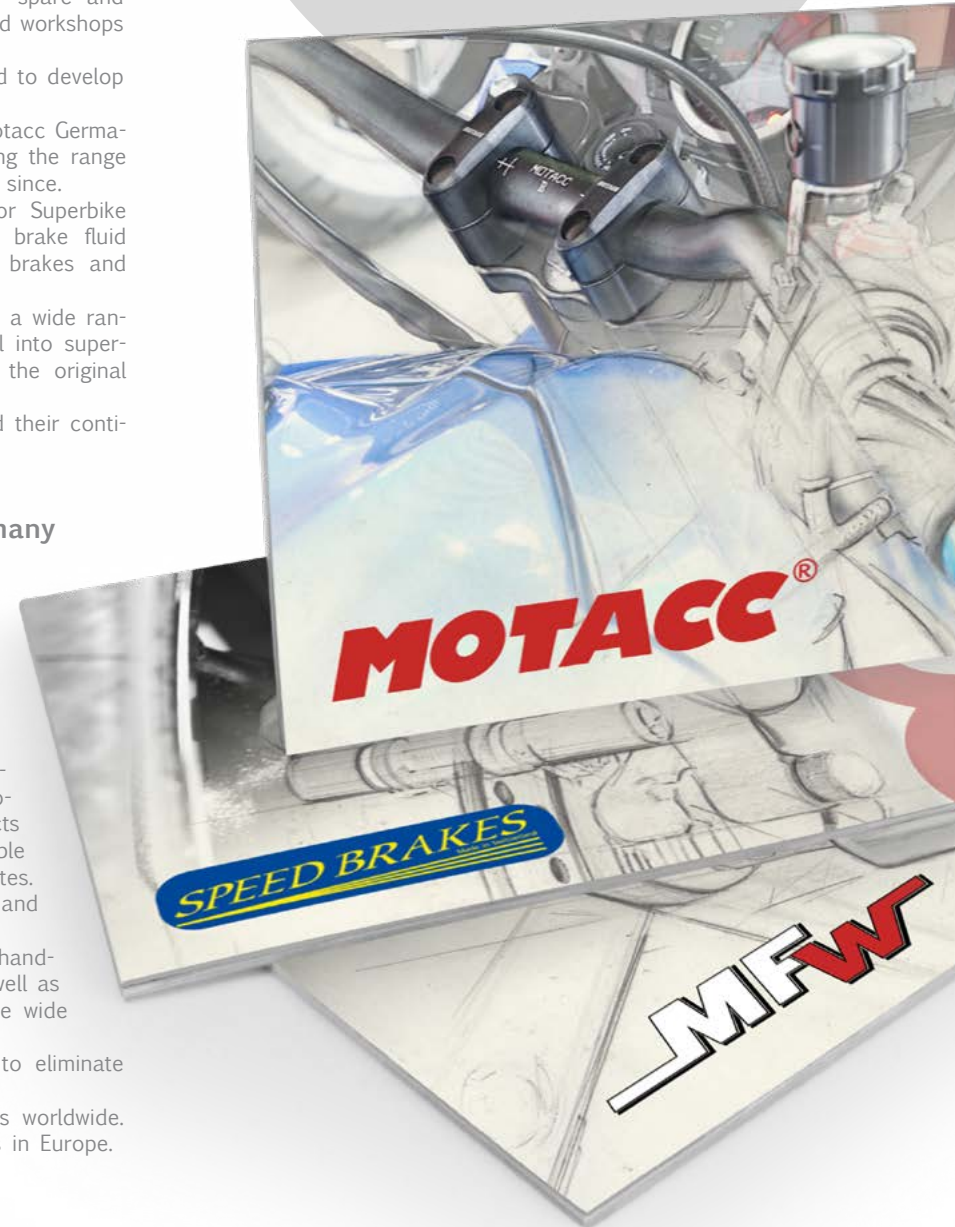

1-5 Superbike Umbauten Superbike conversions

- 1-2 EMS
 - 1 Austausch
Replacements
 - 1 Aufsatz
Mount on adapter
- 3-5 Verwendungsbereich
Range of application

6-19 Lenker-Klemmböcke Handlebar clamps

- 7-14 Superbike & BIGbar Sets
- 15 Lenkererhöhungen
Handlebar Riser
- 16 Zwischenstück
Spacer
- 17 BIGbar Adapter
- 17 BIGbar Erhöhung
BIGbar riser
- 18 Lenkererhöhungen spezial
Handlebar riser specials
- 19 Vario Riser

20 Gas & Chokezüge Throttle & choke cables

21 Kupplungszüge Clutch cables

22 Superbike Zubehör Superbike Accessories

- 22 Verlängerungskits
Extension kits
- 22 Diverse Anbauteile
Various mounting parts

23-24 Lenker Handlebars

- 24 Bohlehre
Drilling jig

25-26 Lenker tuning Handlebar tuning

- 25 Lenkergewichte
Handlebar weights
- 26 Klemmungen
Cotters
- 26 Lenkerverbreiterung
Handlebar extension
- 26 Bremsschutzbügel
Brake lever guard

27-28 Superbike Spiegel Superbike mirror

- 28 Spiegel kits
Mirror kits

29-30 Bremsflussigkeitsbehälter Brake fluid reservoirs

31 Blinker Indicators

32-33 Blinkeradapter Indicator adapters

- 32 Nummernschildbeleuchtung
License plate light

34 Spiegelabdeckungen Mirror covers



35 Hebel Levers

36 Sonderanfertigungen Customised products

50 Werkstatthilfen Workshop support



37 Bremsleitungen
Brake lines



42 Batterien
Batteries



47 Bremskomponenten
Brake components



38 Schnellkupplungen
Quick connectors



43 Kettenräder
Sprockets



48 Motorradständer
Motorbike stands



39 Anbauteile
Attachment parts



44 Motorrad Ketten
Motorbike chains



49 Motorradheber
Motorbike lifters



40 Windschutzschilder
Windshields



45 Bremsscheiben
Brake discs



51 Filter
Filters



41 Auspuff Systeme
Exhaust systems



46 Bremsteile
Braking parts



52 Schmieröle
Lubricants



Superbike Umbauten



MOTACC Gabelbrücken und Lenkerklemmböcke sind die Basis für Komplett-Superbike-Umbauten. Die Komponenten werden aus hochfestem Aluminium auf eigenen CNC Maschinen gefräst. Nach Bedarf werden auch die angepassten Gas- und Kupplungskabel geliefert. Der passende MOTACC-Lenker kann ebenfalls bestellt werden. Drei Umbauvarianten stehen zur Verfügung, die je nach Motorradmodell zum Einsatz kommen: Austausch der Gabelbrücke, EMS (Easy-Mounting-System) oder ein Gabelbrücken-Aufsatz.

Superbike conversions

Top yokes and handlebar clamps of MOTACC are the basis for complete conversions to a superbike. These components are made of high tensile aluminium on CNC machines. They come with fitting throttle and clutch cables. MOTACC handlebars can be mounted too. There are three types of conversions, according to the motorbike model: replacement of the top yoke, EMS (Easy-Mounting-System) or a mount on adapter.

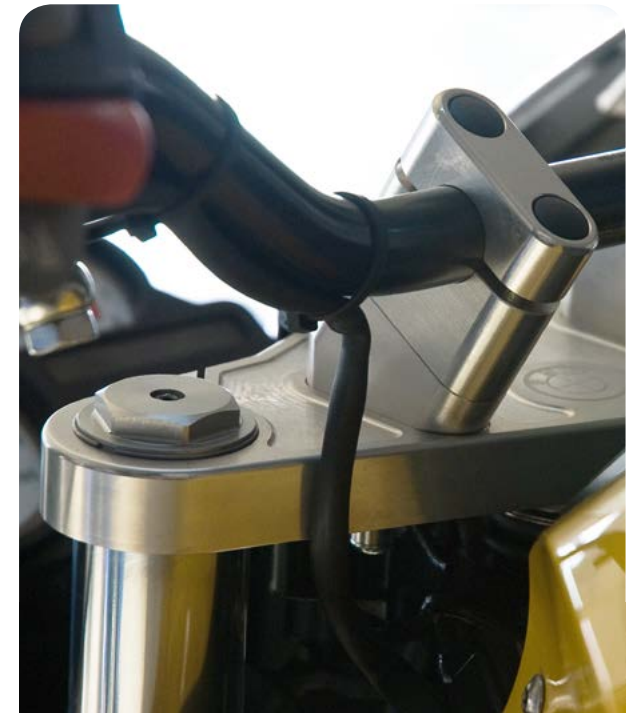

Austausch Replacement

Beim Austausch wird die Original-Gabelbrücke durch eine MOTACC-Gabelbrücke ersetzt und mit MOTACC Lenkerklemmböcken ergänzt.

The original top yoke is replaced by a MOTACC-top yoke accompanied with MOTACC handlebar clamps.



ems

„Wenn möglich ohne Schneiden der Verkleidung!“ lautet der MOTACC-Grundsatz.

Aus dieser Idee wurde das Umbaukonzept EMS (Easy-Mounting-System) entwickelt.

Dies ist ein 3-Punkt-System, mit dem ein Gabelbrücken-Adapter an der Zentralmutter befestigt und zusätzlich zwei Klemmschellen an den Standrohren fixiert sind. Die original Gabelbrücke bleibt montiert und befindet sich „im Sandwich“ der beiden Befestigungsteile.

“No cutting of fairing!” says the MOTACC principle. Out of this idea, the EMS-concept (Easy-Mounting-System) has been developed.

It's a 3-point system, which fixes an yoke adapter to the screw of the central bolting and fits two clamping rings directly to the stand pipes. The original top yoke remains “in the sandwich” of these both fixations.



Aufsatz Mount on adapter

Der MOTACC-Gabelbrücken-Aufsatz wird auf die Original-Gabelbrücke montiert und dient als Basis für die MOTACC-Lenkerklemmböcke. Er kann als Aufsatz-Gabelbrücke oder als Adapter auf den Originalaufnahmepunkten gestaltet sein.

The MOTACC mount on adapter is mounted directly on the original yoke and applicable MOTACC handlebar clamps are mounted onto that adapter. It can be either a bolt on or a clamp on adapter, which both use the original fixing points.



Das EMS-System ***The EMS system***

Das EMS-System bietet folgende Vorteile:

- Die Originalgabelbrücke bleibt erhalten.
- Das Zündschloss muss nicht abgebohrt werden.
- Die Diebstahlsicherung bleibt erhalten.
- Die Verkleidung und die Scheibe müssen in vielen Fällen nicht geschnitten werden.
- Das Motorrad kann jederzeit wieder in den Originalzustand zurückgebaut werden.
- Die Montagezeit wird deutlich verringert.
- Geeignet für Lenker mit 22mm und 28,5mm Rohrdurchmesser.

The EMS system has the following advantages:

- The original top yoke remains.
- There is no need to drill out the ignition lock.
- The anti-theft system remains.
- Usually without cutting of fairing or screen.
- The bike can be restored to its original condition at any time.
- Considerably less mounting time.
- Suitable for 22mm and 28,5mm handlebars.





- 1: MOTACC Aufsatzbrücke / Replacement top yoke
- 2: Originalbrücke / Original top yoke
- 3: Klemmschelle / Clamp
- 4: Distanzhülse / Spacer sleeve



Lenker mit Lenkerverbreiterung
handlebar with extension



Bremsleitung mit Doppelhohlschraube
brake line with double banjo bolt



Verkleidungshalter
fairing mount



Halter für Lenkungsdämpfer
steering damper mount



Zentramutter
central nut



Klemmschelle
clamp



Hupenkabelverlängerung
Horn cable extension



Gaszug
Throttle cable



Gabelbrücke
Top yoke



Verkleidungsunterlage
Fairing basis



Halter für Hydraulikflüssigkeitsbehälter
Hydraulic fluid reservoir mount



Kupplungszug
Clutch cable

Verwendungsbereich

Die Liste zeigt für welche Motorradmodelle welche Superbike-Umbaumöglichkeiten bestehen. Der MOTACC-Umbaukit enthält alle benötigten Teile wie Gabelbrücke oder Adapter, Lenkerklemmböcke, Lenker, Gas- und Kupplungskabel, Bremsschlauch, Hupenkabelverlängerung, Halter für Bremsflüssigkeitsbehälter, usw.

Die Gabelbrücken, Lenkerklemmböcke und Lenker können in den Farben schwarz oder silber gewählt werden. Die Farbe wird mit der Bestellung gewählt. Lenker-Sonderfarben auf Anfrage.

Zusätzlich kann auf viele Modelle der MOTACC Vario Riser montiert werden, wenn in erster Linie rasch und einfach eine Erhöhung des Originallenkers erreicht werden soll (siehe Seite 19). Bei der Liste handelt es sich um einen zusammenfassenden Überblick. Fragen Sie uns zu den Details für den gewünschten Umbau an.

Als Hersteller können wir Ihnen eventuell auch weitere Lösungen für (noch) nicht aufgeführte Modelle anbieten.

Art der Gabelbrücke type of top yoke				*	**				
AT: Austausch-Gabelbrück	replacement top yoke			Motacc Lenker-klemmböcke handlebar clamps	Motacc Lenker typ handlebar type	Zündschloss abbohren drill out ignition lock	Scheiben kürzen cut windscreen	Verkleidung kürzen cut fairing	Art.Nr. Umbau-Kit art.no. conversion kit
AU: Aufsatz-Gabelbrück	bolt on adapter								
AD: Adapter-Gabelbrücke	clamp on adapter								
EMS: Easy Mounting System	easy mounting system								
VR: Vario Riser in Verbindung mit Original-Gabelbrücke	vario riser together with original top yoke								
Modell model	Bj. year	Motorrad Typ bike type							

Honda

CB 600F Hornet	1998	PC34	VR	MV3	S1				74-2040122
CB 600F Hornet	2000	PC34	VR	MV3	S1				74-2040122
CB 600F Hornet	2002	PC36	VR	MV3	S1				74-2040122
CB 600F Hornet	2007	PC41	VR	MV3	S1				74-2040122
CBR 600	1991	PC25	AU	MA3	S1				73-1012001
CBR 600	1995	PC31	AU	MA3	S1				73-1012002
CBR 600	1999	PC35	AU	MB1	S1		X		73-1072001
CBR 600F	2011	PC41	AT	MB1	S1				73-1772101
CBR 600RR	2003	PC37	EMS	MB1	S1		X	X	73-1701001
CBR 600RR	2005	PC37	AT	MB5	S1	X	X	X	73-1711001
CBR 600RR	2007	PC40	AT	MA5	S1	X		X	73-1741001
CBR 600RR	2009	PC40	AT	MA3	S1	X		X	73-1741001
CBR 600RR	2011	PC40	AT	MA3	S1	X	X	X	73-1741001

Range of applications

The list shows which conversion type is possible for which motorbike model. The MOTACC conversion kit contains the necessary top yoke, handlebar clamps, handlebar, throttle and clutch cable, brake line, horn cable extension, holder for brake fluid reservoir, etc.

The top yoke, the handle bar clamps and the handlebar are available in silver or black. The color has to be chosen with the order. Special handlebar colors on demand.

As an alternative the MOTACC vario riser can be mounted on many bike models, if there is quick and easy solution needed for the rising of the original handlebar (see page 19).

This table summarizes our standard offering. Ask us for details of your specific conversion. As manufacturer, we can probably support additional solutions and models, which have not been on the list yet.

Art der Gabelbrücke type of top yoke				*	**				
AT: Austausch-Gabelbrück	replacement top yoke			Motacc Lenker-klemmböcke handlebar clamps	Motacc Lenker typ handlebar type	Zündschloss abbohren drill out ignition lock	Scheiben kürzen cut windscreen	Verkleidung kürzen cut fairing	Art.Nr. Umbau-Kit art.no. conversion kit
AU: Aufsatz-Gabelbrück	bolt on adapter								
AD: Adapter-Gabelbrücke	clamp on adapter								
EMS: Easy Mounting System	easy mounting system								
VR: Vario Riser in Verbindung mit Original-Gabelbrücke	vario riser together with original top yoke								
Modell model	Bj. year	Motorrad Typ bike type							

Kawasaki

ER-6n	2005	ER650A	VR	MV3	S1				74-2040122
ZX- 6R	1998	ZX600G	AT	MB1	S1	X	X	X	73-2061001
ZX- 6R	2000	ZX600J	AT	MB1	S1				73-2751001
ZX- 6R	2003	ZX636B	AT	MB1	S1				73-2761001
ZX- 6R	2005	ZX636C	EMS	MB5	S1				73-2222102
ZX- 6R	2007	ZX600P	EMS	MB5	S1		X	X	73-2222104
ZX- 6R	2009	ZX600RRA	EMS	MA2	S1		X		73-2252101
ZX- 6R	2011	ZX600R	EMS	MA2	S1				73-2243101
ZZR 600	1989	ZX600D	AD	MA3	S1				73-2033001
ZZR 600	1993	ZX600E	AD	MA3	S1		X		73-2033001
ZX- 7R	1996	ZX750P	AT	MA4	S1	X	X	X	73-2011002
GPZ 750	1984	KZ750E	AD	MA3	S1				73-2043001
ZXR 750	1991	ZX750H	AT	MA4	S1	X	X	X	73-2011001

VFR 750	1988	RC24	AU	MA3	S1		X	X	73-1042001
VFR 750	1990	RC36	AU	MB1	S1				73-1032001
VFR 750	1994	RC36	AU	MB1	S1			X	73-1032002
VFR 800	1998	RC46	AU	MB1	S1		X		73-1082001
VFR 800	2002	RC46	AU	MB1	S1				73-1762001
VFR 800	2014	RC79	AU	MA2	S1				73-1762001
CB 900F Hornet	2001	SC48	VR	MV3	S1				74-2040122
CBR 900RR	1995	SC28	AT	MB1	S1	X			73-1021001
CBR 900RR	1995	SC28	AT	MD1	B1	X			73-1021002
CBR 900RR	1996	SC33	AT	MB1	S1	X			73-1021001
CBR 900RR	1996	SC33	AT	MD1	B1	X			73-1021002
CBR 900RR	1998	SC33	AT	MB5	S1	X	X	X	73-1061001
CBR 900RR	2000	SC44	AT	MB5	S1	X			73-1091001
CBR 900RR	2002	SC50	AT	MB5	S1	X			73-1091002
CBF 1000	2006	SC58	VR	MV3	S1				74-2040122
CBR 1000F	1987	SC21	AU	MA3	S1				73-1012003
CBR 1000F	1989	SC24	AU	MA3	S1				73-1012003
CBR 1000RR	2004	SC57	AT	MA4	S4	X			73-1101001
CBR 1000RR	2004	SC57	AT	MC2	B4	X			73-1101002
CBR 1000RR	2006	SC57	AT	MA4	S4	X			73-1101001
CBR 1000RR	2006	SC57	AT	MC2	B4	X			73-1101002
CBR 1000RR	2008	SC59	EMS	MB4	S5				73-1403101
CBR 1000RR	2008	SC59	EMS	MD2	B5				73-1403103
CBR 1000RR ABS	2009	SC59	EMS	MD2	B5				73-1403102
CBR 1000RR ABS	2009	SC59	EMS	MD2	B5				73-1403104
CBR 1000RR	2017	SC77	EMS	MA2	S1				73-1403105
CBR 1000RR	2017	SC77	EMS	MC1	B1				73-1403106
CB 1000R	2008	SC60	VR	MV3	B1				74-2040128
CB 1000R	2011	SC60	VR	MV3	B1				74-2040128
VTR 1000 F	1997	SC36	AU	MB4	S1		X	X	73-1012004
VTR 1000 SP-1	2000	SC45	EMS	MB4	S1		X	X	73-1202101
VTR 1000 SP-2	2002	SC45	EMS	MB4	S1		X	X	73-1202102
X -11	1999	SC42	AU	MA3	S1				73-1732001
CBR 1100XX	1996	SC35	AU	MB1	S1		X		73-1052001
VFR 1200F	2010	SC63	AU	MB1	S1				73-1752001
CB 1300	2003	SC54	VR	MV3	S1				74-2040122

ZXR 750	1991	ZX750J (J)	AT	MA4	S1	X	X	X	73-2011001
ZXR 750R	1991	ZX750J (K)	AT	MA4	S1	X	X	X	73-2011001
ZRX 750 / R	1991	ZX750L (L/M)	AT	MA4	S1	X	X	X	73-2011001
Z 750	2004	ZR750J	VR	MV3	S1				74-2040122
Z 750	2007	ZR750L	VR	MV3	S1				74-2040122
Z 750R	2011	ZR750N	VR	MV3	S1				74-2040122
ZX- 9R	1997	ZX900B	AT	MA5	S1	X	X	X	73-2111001
ZX- 9R	1998	ZX900C (C,D)	AT	MB1	S1	X			73-2051001
ZX- 9R	2000	ZX900E	AT	MB1	S1	X	X	X	73-2081001
ZX- 9R	2002	ZX900E (F)	AT	MB4	S1	X	X	X	73-2071001
GPZ 900	1983	ZX900A	AD	MA3	S1				73-2043002
Z 1000	2003	ZRT00A	VR	MV3	S1				74-2040122
Z 1000	2007	ZRT00B	VR	MV3	B1				74-2040128
Z 1000SX	2011	ZXT00G	VR	MV3	B1				74-2040128
ZX- 10	1988	ZXT00B	AD	MA3	S1				73-2043004
ZX- 10R	2004	ZXT00C	EMS	MB1	S1				73-2222101
ZX- 10R	2006	ZXT00D	EMS	MB5	S1				73-2202101
ZX- 10R	2008	ZXT00E	EMS	MB4	S1				73-2222103
ZX- 10R	2009	ZXT00F	EMS	MB4	S1				73-2222103
ZX- 10R	2011	ZXT00J	EMS	MA2	S1				73-2252102
ZX- 10R	2016	ZXT00S	EMS	MC1	B1				73-2262101
GPZ 1000 RX	1985	ZXT00A	AD	MA3	S1				73-2043003
ZRX 1100	1997	ZRT10C	VR	MV3	S1				74-2040122
GPZ 1100	1995	ZXT10E	AD	MA3	S1				73-2043005
ZZR 1100	1990	ZXT10C	AD	MA3	S1				73-2023001
ZZR 1100	1993	ZXT10D	AD	MA3	S1				73-2023001
ZZR 1200	2002	ZXT20C	AD	MA3	S1				73-2023002
ZRX 1200/S	2001	ZRT20A	VR	MV3	S1				74-2040122
ZX 12R	2000	ZXT20A	AT	MB1	S1				73-2731001
ZX 12R	2002	ZXT20A	AT	MB1	S1				73-2741001
ZZR 1400	2006	ZXT40A/C	AD	MB4	S5		X		73-2702001
1400 GTR	2007	ZGT40A	VR	MV3	S1				71-2001001
1400 GTR	2010	ZGT40C	VR	MV3	S1				74-2040122

* Siehe Seiten / See pages 6-10,19
** Siehe Seiten / See pages 23-24



Art der Gabelbrücke type of top yoke				*	**					
AT:	Austausch-Gabelbrück		replacement top yoke	Motacc Lenker-klemmböcke handlebar clamps	Motacc Lenker typ handlebar type	Zündschloss abbohren drill out ignition lock	Scheiben kürzen cut windscreen	Verkleidung kürzen cut fairing	Art.Nr. Umbau-Kit art.no. conversion kit	
AU:	Aufsatz-Gabelbrück		bolt on adapter							
AD:	Adapter-Gabelbrücke		clamp on adapter							
EMS:	Easy Mounting System		easy mounting system							
VR:	Vario Riser in Verbindung mit Original-Gabelbrücke		vario riser together with original top yoke							
Modell model	Bj. year	Motorrad Typ bike type								

Suzuki

GS 500	2003	BK	VR	MV3	S1				74-2040122
GSR 600	2005	WVB9	VR	MV3	S1				74-2040122
GSX-R 600	1996	AD	AT	MA4	S1	X	X	X	73-3731001
GSX-R 600	2000	WVBG	EMS	MA4	S1				73-3741001
GSX-R 600	2004	WVB2	EMS	MA4	S1				73-3751001
GSX-R 600	2006	WVCE	EMS	MB5	S1				73-3232101
GSX-R 600	2006	WVCE	EMS	MD3	B1				73-3232102
GSX-R 600	2008	WVCV	EMS	MB5	S1				73-3232102
GSX-R 600	2011	WVC3	EMS	MB5	S1			X	73-3232103
RF 600 R		GN76B	AT	MB1	S1	X			73-3111001
GSF 650 Bandit	2007	WVJC	VR	MV3	S1				74-2040122
SV 650 S	1999	AV	EMS	MA3	S1				73-3761001
SV 650 S	2003	WVBY	EMS	MA3	S1				73-3771001
SFV 650 Gladius	2009	WVCX	VR	MV3	S1				74-2040122
GSX-R 750	1985	GR75A	AT	MA3	S1	X	X	X	73-3011001
GSX-R 750	1985	GR75B/C	AT	MA3	S1	X	X	X	73-3011001
GSX-R 750	1988	GR77B	AT	MA3	S1	X	X	X	73-3051001
GSX-R 750	1988	GR77A/C	AT	MA3	S1	X	X	X	73-3051001
GSX-R 750	1988	GR77D	AT	MA3	S1	X	X	X	73-3051001
GSX-R 750	1990	GR7AA	AT	MA5	S1	X	X	X	73-3081001
GSX-R 750	1990	GR7AB	AT	MA5	S1	X	X	X	73-3081001
GSX-R 750 W	1992	GR7BB	AT	MA4	S1	X	X	X	73-3061001
GSX-R 750 W	1994	GR7BB/BC	AT	MA4	S1	X	X	X	73-3101001
GSX-R 750	1992	GR7BC	AT	MA4	S1	X	X	X	73-3061001
GSX-R 750	1996	GR7DB	AT	MA4	S1	X	X	X	73-3101001
GSX-R 750	1996	GR7DA /DC	AT	MA4	S1	X	X	X	73-3131001
GSX-R 750	2000	WVBD	AT	MB5	S1	X			73-3151001
GSX-R 750	2000	WVBD	AT	MD3	B1	X			73-3151003
GSX-R 750	2000	WVBD	AT	MB5	S1	X			73-3151001

Art der Gabelbrücke type of top yoke				*	**					
AT:	Austausch-Gabelbrück		replacement top yoke	Motacc Lenker-klemmböcke handlebar clamps	Motacc Lenker typ handlebar type	Zündschloss abbohren drill out ignition lock	Scheiben kürzen cut windscreen	Verkleidung kürzen cut fairing	Art.Nr. Umbau-Kit art.no. conversion kit	
AU:	Aufsatz-Gabelbrück		bolt on adapter							
AD:	Adapter-Gabelbrücke		clamp on adapter							
EMS:	Easy Mounting System		easy mounting system							
VR:	Vario Riser in Verbindung mit Original-Gabelbrücke		vario riser together with original top yoke							
Modell model	Bj. year	Motorrad Typ bike type								

Yamaha

FZR 600 N	1989	3RH/HF	AT	MA5	S1	X	X	X	73-4071001
FZR 600 H	1989	3RG	AT	MA5	S1	X	X	X	73-4071001
FZR 600 HH	1989	3HE	AT	MA5	S1	X	X	X	73-4071001
FZR 600 RH	1994	4JH	AU	MA4	S1		X	X	73-4052001
FZR 600 RH	1994	4MM	AU	MA4	S1		X	X	73-4052001
FZR 600 R	1994	4MH	AU	MA4	S1		X	X	73-4052001
YZF 600 R	1996	4TV	AU	MA4	S1		X	X	73-4052002
YZF 600 R	1996	4VT	AU	MA4	S1		X	X	73-4052002
YZF - R6	2003	RJ05-RJ091	AD	MB5	S1				73-4242001
YZF - R6	2005	RJ09-RJ095	AD	MB3	S1				73-4222001
YZF - R6	2006	RJ11	AD	MA4	S1				73-4202002
YZF - R6	2008	RJ15	AD	MA4	S1				73-4202003
YZF - R6	2010	RJ15	AU	MB3	S1				73-4262001
YZF - R6	2010	RJ15	AU	MD1	B1				73-4262002
FZ 750	1985	1FN	AD	MA3	S1				73-4043001
FZ 750	1985	1FV	AD	MA3	S1				73-4043001
FZ 750	1986	2KK	AD	MA3	S1				73-4043001
FZ 750		2MH	AD	MA3	S1				73-4043001
FZ 750	1990	3KT	AD	MA3	S1				73-4043001
YZF 750	1993	4HN	AT	MA4	S1	X	X	X	73-4031001
YZF 750		4HR	AT	MA4	S1	X	X	X	73-4031001
YZF 750	1993	4HT	AT	MA4	S1	X	X	X	73-4031001
YZF 750		4FM, 4HD	AT	MA4	S1	X	X	X	73-4031001
FZ-8N	2010	RN25	VR	MV3	S1				74-2040122
TRX 850	1996	4UN	AU	MA4	S1		X	X	73-4052003
FZS 1000 Fazer	2001	RN06	VR	MV3	S1				74-2040122
FZS 1000 Fazer	2004	RN14	VR	MV3	S1				74-2040122
FZ1 / Fazer	2006	RN16	VR	MV3	S1				74-2040122
FZR 1000 Genesis	1987	2LA, 3CB	AT	MA3	S1	X	X	X	73-4061001

GSX-R 750	2004	WVB3	EMS	MB2	S1				73-3212101
GSX-R 750	2004	WVB3	EMS	MC1	B1				73-3212102
GSX-R 750	2006	WVCF	EMS	MB5	S1				73-3232101
GSX-R 750	2008	WVCW	EMS	MB5	S1				73-3232102
GSX-R 750	2011	WVC4	EMS	MB1	S1		X		73-3232103
GSR 750	2011	WVC5	VR	MV3	S1				74-2040122
RF 900	1993	GT73B	AU	MB1	S1				73-3072001
RF 900	1993	GT73C	AU	MB1	S1				73-3072001
GSXR 1000	2001	WVBL/BL1112	AT	MB5	S1	X	X		73-3151002
GSXR 1000	2003	WVBZ/BZ1110	AT	MA2	S1	X	X		73-3171001
GSXR 1000	2005	WVB6	EMS	MB5	S1				73-3212101
GSXR 1000	2007	WVCL	EMS	MB4	S1				73-3202101
GSXR 1000	2009	WVCY	EMS	MA4	S1				73-3202102
GSXR 1000	2009	WVCY	EMS	MC2	B1				73-3202104
GSXR 1000	2017	WDM0	EMS	MD1	B1				73-3202103
SV 1000	2002	WVBX/BX1321	AT	MB1	S1	X			73-3161011
TL 1000 (S)	1996	AG	AT	MA5	S1	X	X	X	73-3131002
GSX-R 1100	1986	GU74C	AT	MA4	S1	X	X	X	73-3021001
GSX-R 1100	1986	GU74A/B/D	AT	MA4	S1	X	X	X	73-3021001
GSX-R 1100 W	1989	GV73C	AT	MA5	S1	X	X	X	73-3091001
GSX-R 1100	1990	GV73C	AU	MA4	S1		X	X	73-3032001
GSX-R 1100 W	1989	GV73A/B	AT	MA5	S1	X	X	X	73-3091001
GSX-R 1100	1990	GV73A/B/E	AU	MA4	S1		X	X	73-3032001
GSX-R 1100 W	1993	GU75C	AU	MA5	S1		X	X	73-3042001
GSX-R 1100 W	1993	GU75A/D	AU	MA5	S1		X	X	73-3042001
GSF 1200	1996	GV75A	VR	MV3	S1				74-2040122
GSF 1200	2001	WVB9	VR	MV3	S1				74-2040122
GSF 1200	2005	WVCB	VR	MV3	S1				74-2040122
GSF 1250	2007	WVCH	VR	MV3	S1				74-2040122
GSX-R 1300 Hayab.	1999	WVA1	AU	MB4	S1		X		73-3142001
GSX-R 1300 Hayab.	2008	WVCK	AU	MB5	S1		X		73-3142002
GSX 1400	2002	WVBN	VR	MV3	S1				74-2040122
GSX 1300BK	2008	WVCR	-	MD4	B1				74-2033473

FZR 1000	1987	2LE,2LF	AT	MA3	S1	X	X	X	73-4061001
FZR 1000	1990	3LK, 3GM	AT	MA3	S1	X	X	X	73-4011001
FZR 1000 o. USD	1990	3LE	AT	MA3	S1	X	X	X	73-4011001
FZR 1000 m.UPSD	1991	3LF, 3LG, 3LH	AT	MA3	S1	X	X	X	73-4021001
YZF 1000R	1996	4VD	AT	MA4	S1	X	X	X	73-4081001
YZF - R1	1998	RN01	AT	MB1	S1	X	X	X	73-4091001
YZF - R1	2000	RN04	AT	MB1	S1	X	X	X	73-4091001
YZF - R1	2002	RN09	AT	MB1	S1	X			73-4101001
YZF - R1	2002	RN09	AU	MB1	S1				73-4212001
YZF - R1	2004	RN12	AU	MB5	S1				73-4202001
YZF - R1	2007	RN19	AU	MB5	S1				73-4212002
YZF - R1	2009	RN22	AU	MB5	S1				73-4212003
YZF - R1	2015	RN32	AU	MB1	S1		X	X	73-4262001
YZF - R1	2015	RN32	AU	MD1	B1		X	X	73-4262003
YZF - R1	2017	RN49	AU	MB1	S1		X	X	73-4262001
YZF - R1	2017	RN49	AU	MD1	S1		X	X	73-4262003
BT 1000 Bulldog	2002	RP05	VR	MV3	S1				74-2040122
XJR 1200	1995	4PU	VR	MV3	S1				74-2040122
FJ 1200	1986	1 XJ	AD	MA3	S1				73-4723001
FJ 1200	1988	3 CW	AD	MA3	S1				73-4723001
FJ 1200	1990	3 YA	AD	MA3	S1				73-4723001
XJR 1300	1998	RP01	VR	MV3	S1				74-2040122
XJR 1300	1999	RP02	VR	MV3	S1				74-2040122
XJR 1300	2001	RP06	VR	MV3	S1				74-2040122
XJR 1300	2004	RP10	VR	MV3	S1				74-2040122
XJR 1300	2003	RP11	-	MC1	B1				74-4440001
FJR 1300	2006	RP13	AD	MD4	B1				73-4253001
FJR 1300	2007	RP13	VR	MD4	B1				74-2040122
FJR 1300	2012	RP23	AD	MC2	B1				73-4273001
FJR 1300	2016	RP28	AD	MC2	B1				73-4273002
MT-01	2005	RP12	VR	MV3	S1				74-2040122

* Siehe Seiten / See pages 6-10,19
** Siehe Seiten / See pages 23-24



Art der Gabelbrücke type of top yoke				*	**				
AT:	Austausch-Gabelbrück	replacement top yoke		Motacc Lenker-klemmböcke handlebar clamps	Motacc Lenker typ handlebar type	Zündschloss abbohren drill out ignition lock	Scheiben kürzen cut windscreen	Verkleidung kürzen cut fairing	Art.Nr. Umbau-Kit art.no. conversion kit
AU:	Aufsatz-Gabelbrück	bolt on adapter							
AD:	Adapter-Gabelbrücke	clamp on adapter							
EMS:	Easy Mounting System	easy mounting system							
VR:	Vario Riser in Verbindung mit Original-Gabelbrücke	vario riser together with original top yoke							
Modell model	Bj. year	Motorrad Typ bike type							

Aprilia

RSV Mille 1000	1997	ME	AT	MA5	S1	X		X	73-5011001
SL Falco 1000	2000	PA	AT	MA5	S1	X		X	73-5011002
RSV4, RSV4 R	2009	RK	AU	MC2	S1				73-5011003
RSV4	2017	RK	AU						73-5212001
Tuono 1000	2006	RR	VR	MV3	B1				74-2040128

BMW

F 800 S	2007	E8ST	AT	MA3	S1				73-6701001
R 850R	1996	259	AU	MA3	S1				73-6012001
R 850R	1997	259	AU	MA4	S1				73-6022001
S 1000RR	2009	K10/507	AU	MB5	S5				73-6761004
S 1000RR	2009	K10/507	AU	MD2	B1				73-6761003
S 1000RR	2012	K10/524	AU	MC1	B1				73-6771005
S 1000RR	2015	K10/D10	AU	MB4	S1				73-6782101
S 1000RR	2015	K10/D10	AU	MC2	B1				73-6782103
R 1100R	1996	259	AU	MA3	S1				73-6012001
R 1100R	1997	259	AU	MA4	S1				73-6022001
R 1100S	1998	R2S	AT	MA3	S1				73-6731001
R 1100S	2001	R2S	AT	MA3	S1				73-6731002
R 1100S	2004	R2S	AT	MA3	S1				73-6731003
K 1200S	2004	K12S	AD	MA2	S1				73-6721001
K 1200S	2004	K12S	AD	MC1	B1				73-6721002
K 1200R	2005	K12R	AD	MA2	S1				73-6721001
K 1200R	2005	K12R	AD	MC1	B1				73-6721002
R 1200S	2006	R12S	AT	MB3	S1	X			73-6741001
R 1200R	2007	R12ST	AT	MB3	S1				73-6711001
K 1300R	2009	K12S	AD	MC1	B1				73-6721003
K 1300S	2008	K12S	AD	MC1	B1				73-6721003

KTM

RC8 R	2009	KTM RC8	AD	MC2	B1				73-9012001
-------	------	---------	----	-----	----	--	--	--	------------

Art der Gabelbrücke type of top yoke				*	**				
AT:	Austausch-Gabelbrück	replacement top yoke		Motacc Lenker-klemmböcke handlebar clamps	Motacc Lenker typ handlebar type	Zündschloss abbohren drill out ignition lock	Scheiben kürzen cut windscreen	Verkleidung kürzen cut fairing	Art.Nr. Umbau-Kit art.no. conversion kit
AU:	Aufsatz-Gabelbrück	bolt on adapter							
AD:	Adapter-Gabelbrücke	clamp on adapter							
EMS:	Easy Mounting System	easy mounting system							
VR:	Vario Riser in Verbindung mit Original-Gabelbrücke	vario riser together with original top yoke							
Modell model	Bj. year	Motorrad Typ bike type							

Triumph

Street Triple	2007	D67LD	VR	MV3	S1				74-2040122
Trident750	1992	T300	AU	MA3	S1				73-7052003
Trident750	1994	T300 C	AU	MA3	S1				73-7052003
Daytona 900	1993	T300	AU	MB1	S1				73-7062001
Daytona 900 (III)	1994	T300D	AU	MB1	S1				73-7062001
SpeedTriple 900	1994	T300B	AT	MA5	S1				73-7011001
StreetTriple	2007	D67LD	VR	MV3	S1				74-2040122
Sprint ST	1999	T695	AU	MA3	S1				73-7052003
Sprint RS	2000	T695	AU	MA3	S1				73-7052003
Sprint 900	1993	T300A/C	AU	MA3	S1				73-7052003
Trophy 900	1994	T300E	AU	MA3	S1				73-7052003
Speed Triple 955i	1997	595RPT	VR	MV3	S1				74-2040122
Sprint ST	2005	215NA	AD	MA3	S1				73-7703001
Sprint ST	2007	215NA	AD	MA3	S1				73-7703002
Tiger 1050	2007	115NG	VR	MV3	S1				74-2040122
Speed Triple 1050	2005	515NJ	VR	MV3	S1				74-2040122
Speed Triple 1050	2006	515NJ	VR	MV3	S1				74-2040122

MV Agusta

F4 750S	1999	F4	EMS	MB5	S1		X	X	73-9403101
F4 750S	1999	F4	EMS	MD4	B1		X	X	73-9403102
F4 1000S	2004	F5	EMS	MB5	S1		X	X	73-9403101
F4 1000S	2004	F5	EMS	MD4	B1		X	X	73-9403102
F4 1000R	2005	F5	EMS	MB5	S1		X	X	73-9403101
F4 1000R	2005	F5	EMS	MD4	B1		X	X	73-9403102
F4 1000 R 312	2007	F5	EMS	MB5	S1		X	X	73-9403101
F4 1000 R 312	2007	F5	EMS	MD4	B1		X	X	73-9403102
F4 1078RR 312	2008	F5	EMS	MB5	S1		X	X	73-9403101
F4 1078RR 312	2008	F5	EMS	MD4	B1		X	X	73-9403102

Ducati								
748	1995	748	EMS	MB5	S1	X	X	73-8403101
748	1999	H3	EMS	MB5	S1	X	X	73-8403101
749	2002	H5	EMS	MB5	S1	X	X	73-8403101
916	1994	916	EMS	MB5	S1	X	X	73-8403101
996	1999	H2	EMS	MB5	S1	X	X	73-8403101
998	2002	H2	EMS	MB5	S1	X	X	73-8403101
Panigale 899	2013	H8	EMS	MD1	B1			74-8411001
Panigale 959	2016	HA	EMS	MD1	B1			74-8411001
Panigale 959	2016	HA	EMS	MD1	B1			74-8411001
Panigale 959	2016	HB	EMS	MD1	B1			74-8411001
Panigale 1199	2012	H8	EMS	MD1	B1			74-8411001
Panigale 1299	2015	H9	EMS	MD1	B1			74-8411001
Panigale 1299	2017	HC	EMS	MD1	B1			74-8411001
Panigale 1299 R	2017	HD	EMS	MD1	B1			74-8411001

* Siehe Seiten / See pages 6-10,19
 ** Siehe Seiten / See pages 23-24

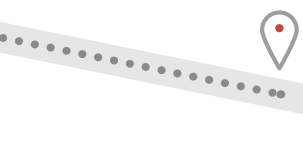
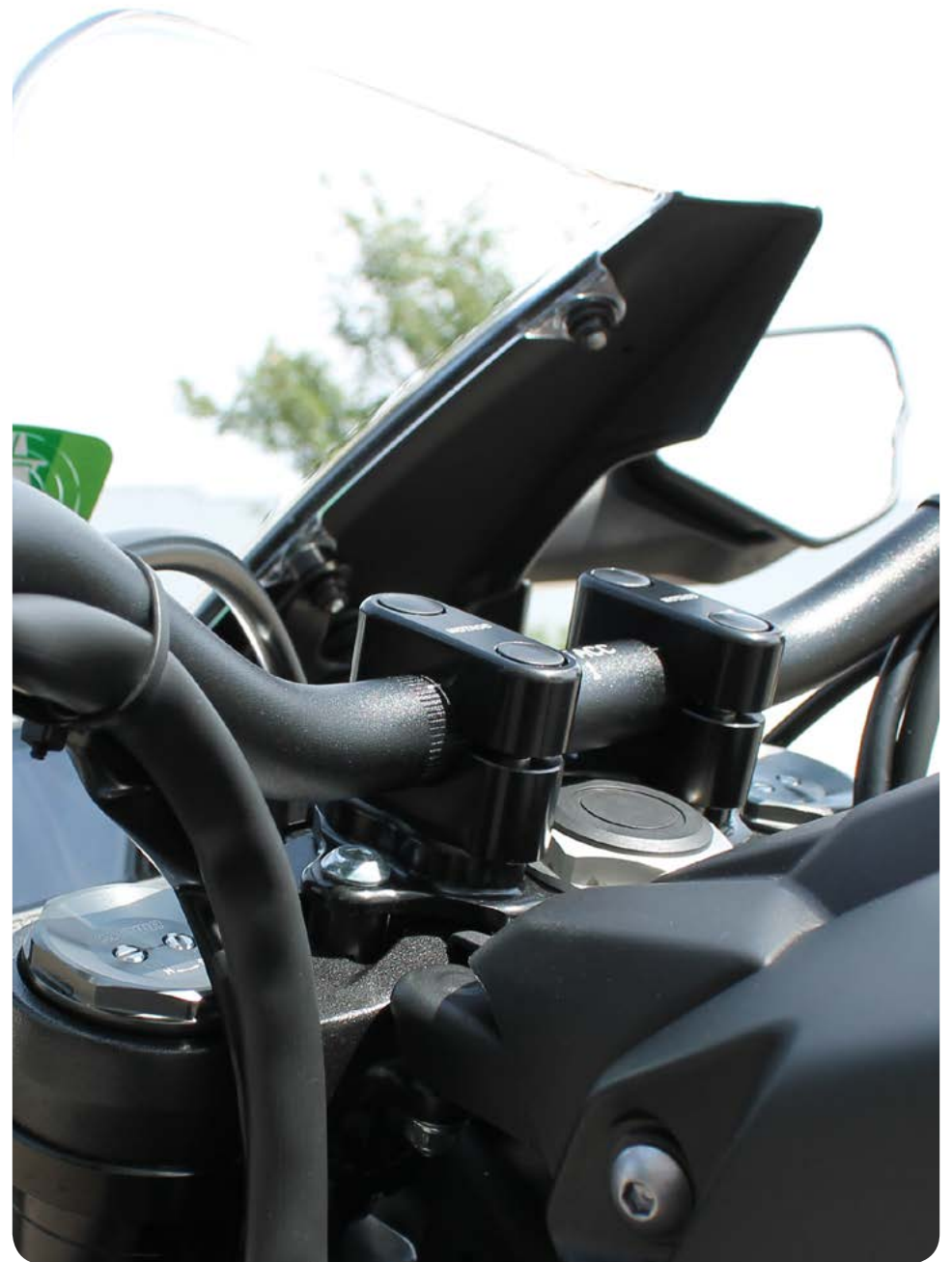



Lenkerklemmböcke ***Handlebar clamps***

Mit unserem modularen Baukastensystem können Sie Lenkerklemmböcke für die Verbesserung des Fahrkomforts individuell zusammenstellen.

Unsere Superbike-Komplettumbauten werden von uns mit den passenden Lenkerklemmböcken für das jeweilige Modell ausgeliefert.

Für Spezialumbauten ist dagegen unser modulares Baukastensystem interessant. Unsere Lenkerklemmböcke aus hochfestem Aluminium unterscheiden sich in Lenkerdurchmesser, Höhe sowie Kröpfung und lassen somit viele Kombinationsmöglichkeiten zu.

MOTACC Lenkerklemmböcke passen auf alle MOTACC-Gabelbrücken, und können in vielen Fällen auf Originalgabelbrücken oder Gabelbrücken anderer Hersteller verbaut werden.

Für Fragen bezüglich solcher Spezialumbauten stehen wir Ihnen gerne zur Verfügung und unterstützen Sie bei der Wahl Ihrer Lenkerklemmböcke.

Optimize your ride comfort: Our handlebar clamps of high tensile aluminium come in a modular design, which allows you to set up handlebar clamps according to your needs.

Our Superbike modification kits contain the appropriate handlebar clamps for each bike model. For custom bikes you combine our handlebar clamps, which differ in handlebar diameter, height and crank.

MOTACC handlebar clamps fit with MOTACC top yokes and often with original ones or with top yokes of other suppliers. Do not hesitate to contact us for your special conversion.



Superbike Sets

Gerade / straight

MA Ø 22mm

Dieses Set besteht aus einem Paar Lenkerklemmböcken aus hochfestem Aluminium in gerader Ausführung für Lenkerdurchmesser 22mm, mit Schrauben und Kunststoff-Schraubenabdeckkappen.

Erhältlich in den vier Höhen 20mm, 30mm, 40mm und 50mm in der Farbe Schwarz oder Silber.

Informationen zu den Einzelteilen des Sets auf Anfrage. Passend auf alle MOTACC-Gabelbrücken – für die Optimierung des Fahrkomforts.

This set contains a pair of handlebar clamps of high tensile aluminium in straight design for handlebars with 22mm diameter and comes with screws and plastic screw cover caps.

Available in heights 20mm, 30mm, 40mm and 50mm in color black or silver.

Further Information about the single parts on demand. Fitting with all MOTACC top yokes – optimize your drive comfort.

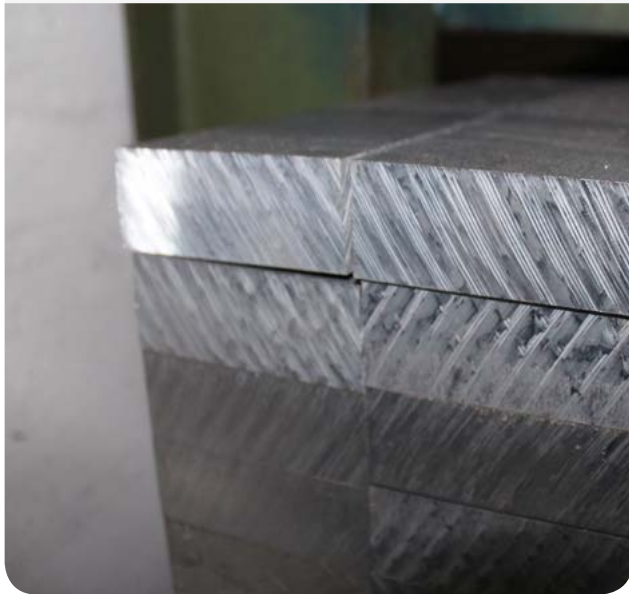

MA4-08



MA5-08



MA3-08



MA2-08

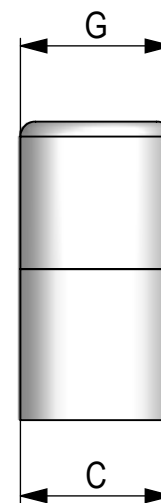
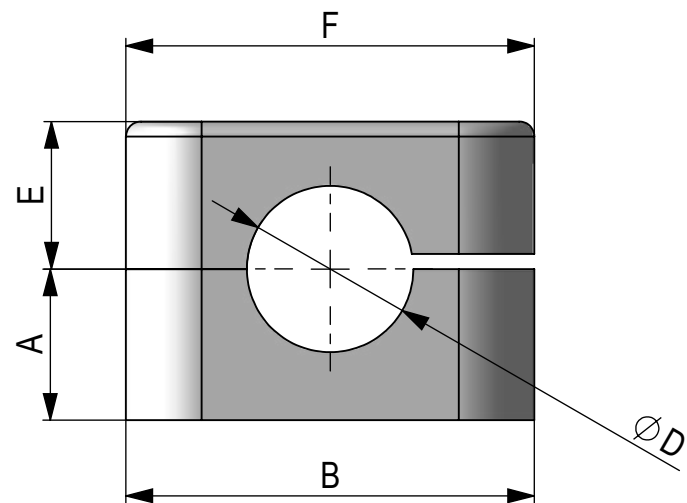

Superbike Sets gerade / straight

Art.-Nr./ art. no.	A	B	C	Ø D	E	F	G
MA2-08 MA2-01	20mm	54mm	20mm	Ø 22mm	20mm	54mm	20mm
MA3-08 MA3-01	30mm	54mm	20mm	Ø 22mm	20mm	54mm	20mm
MA4-08 MA4-01	40mm	54mm	20mm	Ø 22mm	20mm	54mm	20mm
MA5-08 MA5-01	50mm	54mm	20mm	Ø 22mm	20mm	54mm	20mm



Superbike Sets

Gekröpft / cranked

MB Ø 22mm 30°

Dieses Set besteht aus einem Paar Lenkerklemmböcken aus hochfestem Aluminium in 30° gekröpfter Ausführung für Lenkerdurchmesser 22mm, mit Schrauben und Kunststoff-Schraubenabdeckkappen.

Erhältlich in den vier Höhen 41mm, 50mm, 58mm und 67mm in der Farbe Schwarz oder Silber.

Informationen zu den Einzelteilen des Sets auf Anfrage. Passend auf alle MOTACC-Gabelbrücken - für die Optimierung des Fahrkomforts.

This set contains a pair of handlebar clamps of high tensile aluminium in 30° cranked design for handlebars with 22mm diameter and comes with screws and plastic screw cover caps.

Available in heights 41mm, 50mm, 58mm and 67mm in color black or silver.

Further Information about the single parts on demand. Fitting with all MOTACC top yokes - optimize your drive comfort.



MB1-08

MB2-08

MB3-08



MB4-08

MB5-08

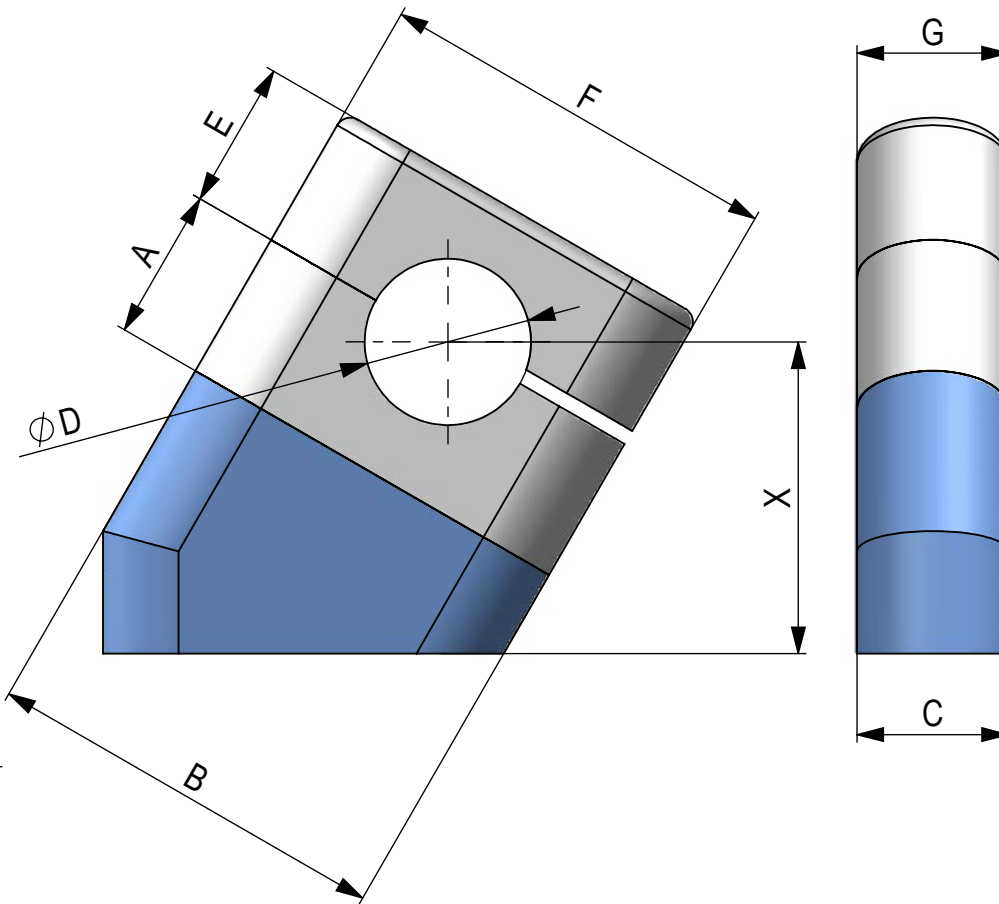
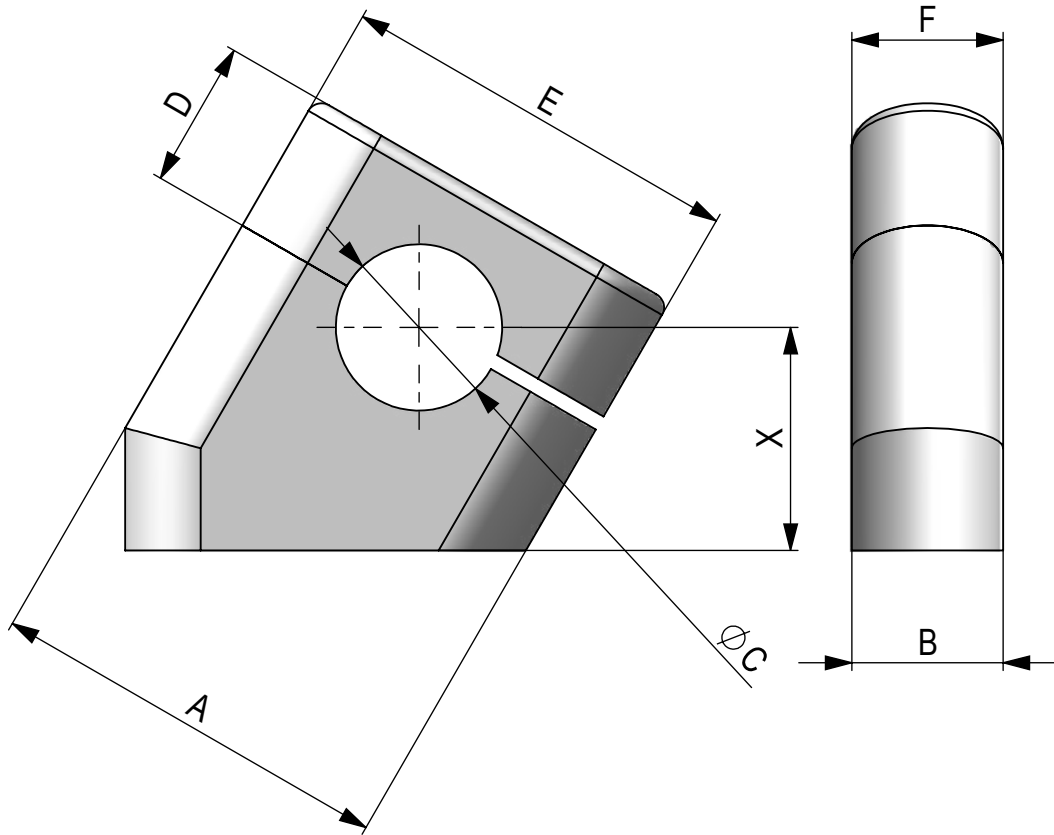

Superbike Set direkt gekröpft / cranked 30°

Art.-Nr./ art. no.	A	B	Ø C	D	X	E	F
MB1-08 MB1-01	54mm	20mm	Ø 22mm	19,5mm	30mm	54mm	20mm

Superbike Sets gekröpft / cranked 30°

Art.-Nr./ art. no.	A	B	C	Ø D	X	E	F	G
MB2-08 MB2-01	20mm	54mm	20mm	Ø 22mm	41mm	19,5mm	54mm	20mm
MB3-08 MB3-01	30mm	54mm	20mm	Ø 22mm	50mm	19,5mm	54mm	20mm
MB4-08 MB4-01	40mm	54mm	20mm	Ø 22mm	58mm	19,5mm	54mm	20mm
MB5-08 MB5-01	50mm	54mm	20mm	Ø 22mm	67mm	19,5mm	54mm	20mm



BIGbar Sets

Gerade / straight

MC Ø 25,4mm (1")/ 28,5mm

Dieses Set besteht aus einem Paar Lenkerklemmböcken aus hochfestem Aluminium in gerader Ausführung für Lenkerdurchmesser 28,5mm (BIGbar-Lenker) oder 25,4mm (1"-Lenker) mit Schrauben und Kunststoff-Schraubenabdeckkappen.

Erhältlich in den Höhen 30mm, 40mm, 50mm und 60mm (BIGbar-Lenker) oder 40mm und 60mm (1"-Lenker) in der Farbe Schwarz oder Silber.

Informationen zu den Einzelteilen des Sets auf Anfrage. Passend auf alle MOTACC-Gabelbrücken - für die Optimierung des Fahrkomforts.

This set contains a pair of handlebar clamps of high tensile aluminium in straight design for handlebars with 28,5mm (BIGbar-handlebar) or 25,4mm (1"-handlebar) and comes with screws and plastic screw cover caps. Available in heights 30mm, 40mm, 50mm and 60mm (BIGbar-handlebar) or 40mm and 60mm (1"-handlebar) in color black or silver.

Further Information about the single parts on demand. Fitting with all MOTACC top yokes - optimize your drive comfort.



MC4-08



MC3-08



MC2-08



MC1-08



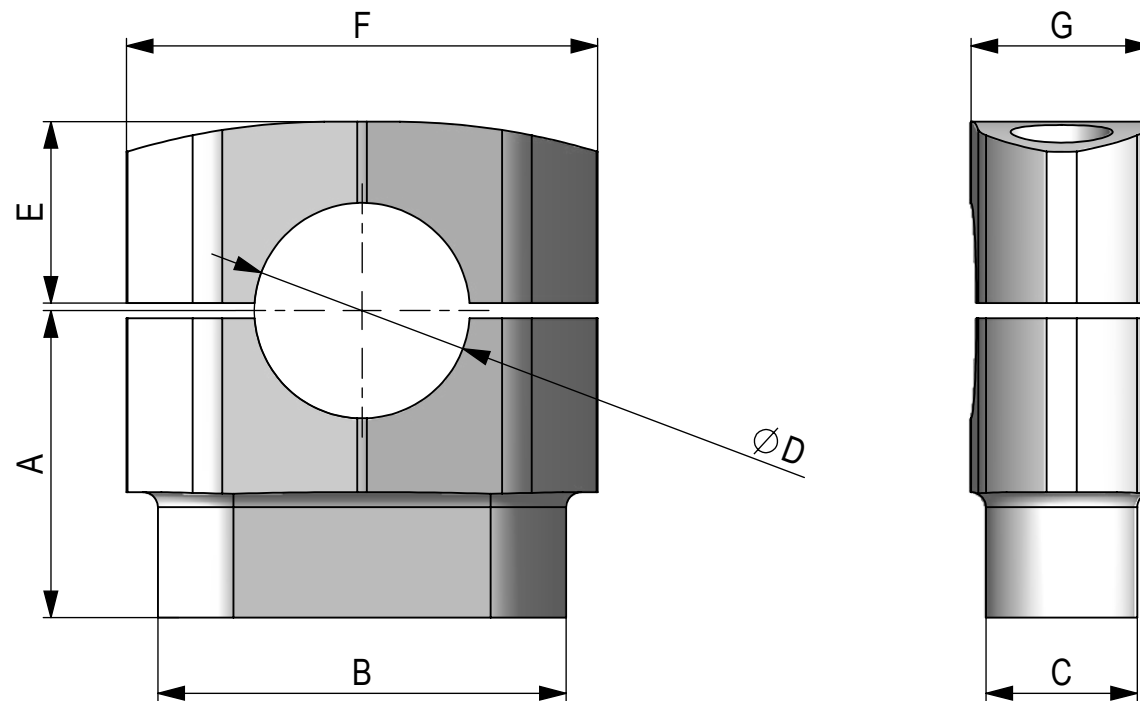

BIGbar Sets gerade / straight

Art.-Nr./ art. no.	A	B	C	Ø D	E	F	G
MC5-08 MC5-01	40mm	54mm	20mm	Ø 25,4mm (1")	24mm	62mm	24mm
MC6-08 MC6-01	60mm	54mm	20mm	Ø 25,4mm (1")	24mm	62mm	24mm



Art.-Nr./ art. no.	A	B	C	Ø D	E	F	G
MC1-08 MC1-01	30mm	54mm	20mm	Ø 28,5mm	24mm	62mm	24mm
MC2-08 MC2-01	40mm	54mm	20mm	Ø 28,5mm	24mm	62mm	24mm
MC3-08 MC3-01	50mm	54mm	20mm	Ø 28,5mm	24mm	62mm	24mm
MC4-08 MC4-01	60mm	54mm	20mm	Ø 28,5mm	24mm	62mm	24mm



BIGbar Sets

Gekröpft / cranked

MD Ø 25,4mm (1")/ 28,5mm

Dieses Set besteht aus einem Paar Lenkerklemmböcken aus hochfestem Aluminium in 30° gekröpfter Ausführung für Lenkerdurchmesser 28,5mm (BIGbar-Lenker) oder 25,4mm (1"-Lenker) mit Schrauben und Kunststoff-Schraubenabdeckkappen.

Erhältlich in den Höhen 50mm, 59mm, 67mm und 76mm (BIGbar-Lenker) oder 59mm und 76mm (1"-Lenker) in der Farbe Schwarz oder Silber.

Informationen zu den Einzelteilen des Sets auf Anfrage. Passend auf alle MOTACC-Gabelbrücken - für die Optimierung des Fahrkomforts.

This set contains a pair of handlebar clamps of high tensile aluminium in 30° cranked design for handlebars with 28,5mm (BIGbar-handlebar) or 25,4mm (1"-handlebar) and comes with screws and plastic screw cover caps.

Available in heights 50mm, 59mm, 67mm and 76mm (BIGbar-handlebar) or 59mm and 76mm (1"-handlebar) in color black or silver.

Further Information about the single parts on demand. Fitting with all MOTACC top yokes - optimize your drive comfort.



MD4-08



MD3-08



MD2-08



MD1-08

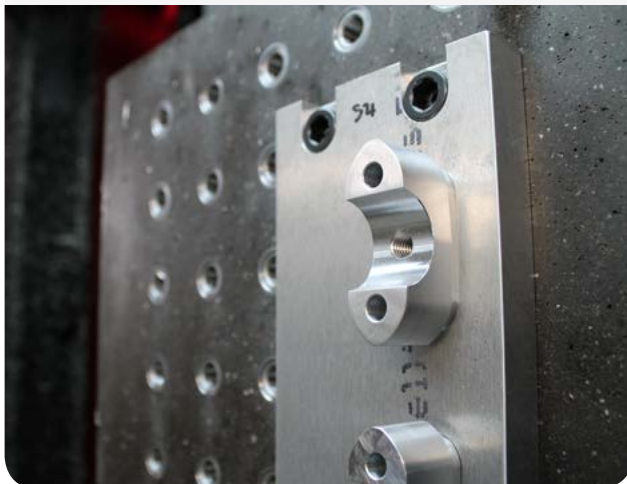

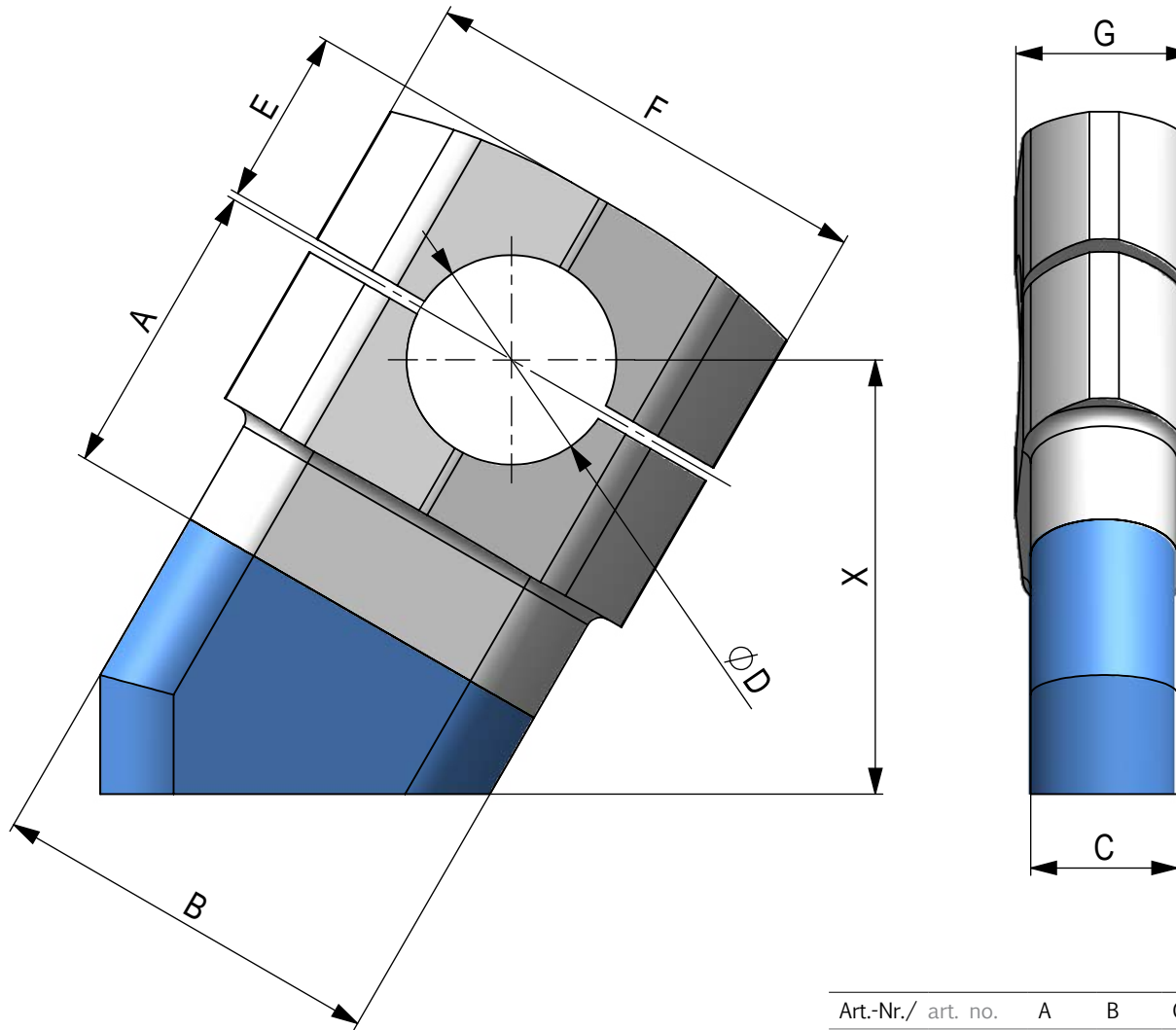

BIGbar Sets gekröpft / cranked 30 °

Art.-Nr./ art. no.	A	B	C	Ø D	X	E	F	G
MD5-08 MD5-01	40mm	54mm	20mm	Ø 25,4mm (1")	59mm	24mm	62mm	24mm
MD6-08 MD6-01	60mm	54mm	20mm	Ø 25,4mm (1")	76mm	24mm	62mm	24mm

Art.-Nr./ art. no.	A	B	C	Ø D	X	E	F	G
MD1-08 MD1-01	30mm	54mm	20mm	Ø 28,5mm	50mm	24mm	62mm	24mm
MD2-08 MD2-01	40mm	54mm	20mm	Ø 28,5mm	59mm	24mm	62mm	24mm
MD3-08 MD3-01	50mm	54mm	20mm	Ø 28,5mm	67mm	24mm	62mm	24mm
MD4-08 MD4-01	60mm	54mm	20mm	Ø 28,5mm	76mm	24mm	62mm	24mm

Superbike Sets

Gerade mit Adapter und Rondelle

Straight with adapter and rondel

ME Ø 22mm

Dieses Set besteht aus einem Paar Lenkerklemmböcken aus hochfestem Aluminium in gerader Ausführung mit Adapter und Rondelle für Lenkerdurchmesser 22mm, mit Schrauben und Kunststoff-Schraubenabdeckkappen. Erhältlich in den vier Höhen 48mm, 58mm, 68mm und 78mm in der Farbe Schwarz oder Silber.

Informationen zu den Einzelteilen des Sets auf Anfrage. Ideal für Café-Racer und Classic-Umbauten. Montage auf viele Original-Gabelbrücken möglich - für verbesserten Fahrkomfort.

This set contains a pair of handlebar clamps of high tensile aluminium with adapter and rondel in straight design for handlebars with 22mm diameter and comes with screws and plastic screw cover caps.

Available in heights 48mm, 58mm, 68mm and 78mm in color black or silver.

Further Information about the single parts on demand. Appropriate for Café-Racer and classic conversions. Fit with various original top yokes. Optimize your drive comfort.



ME3-08

ME4-08



ME1-08

ME2-08

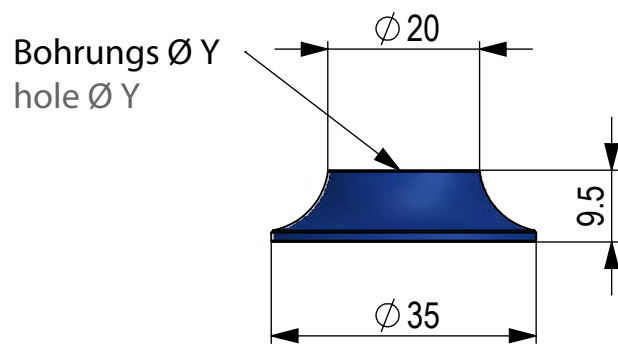

Rondelle / rondel Ø 35

Art.-Nr./ art. no.	Ø Y
74-2330210yy*	Ø 10mm
74-2330212yy*	Ø 12mm

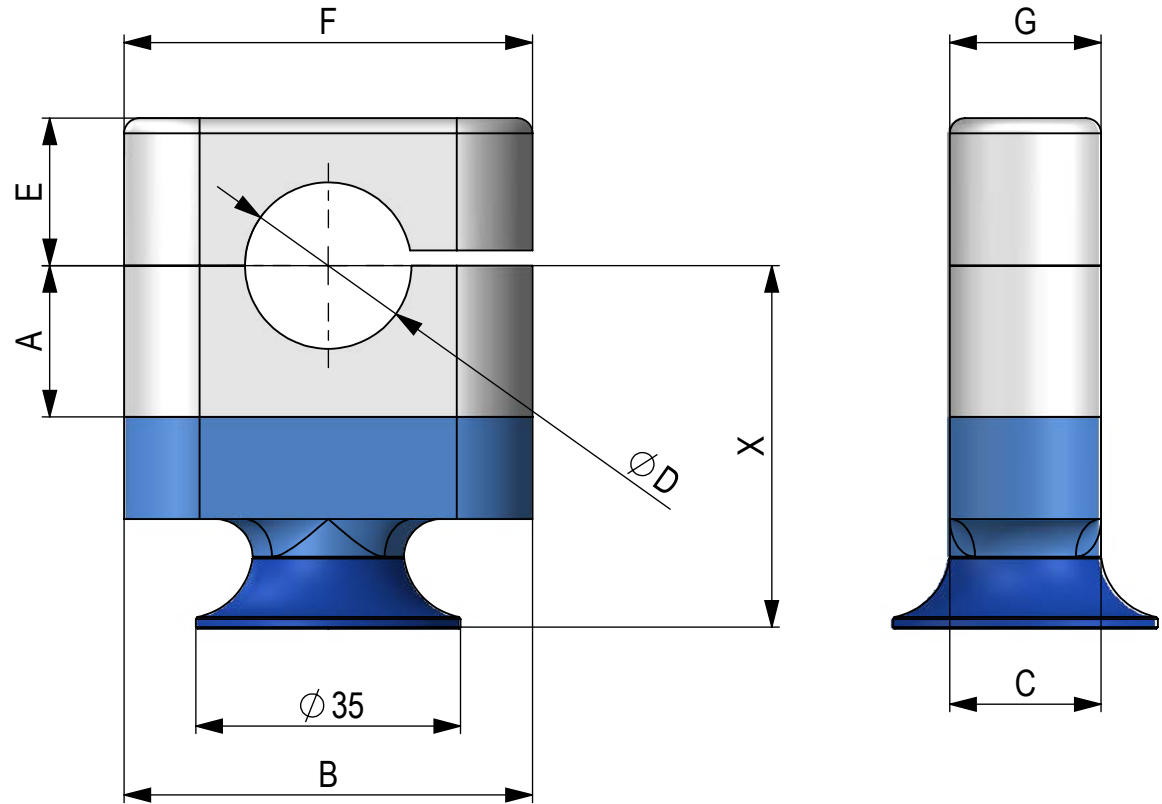
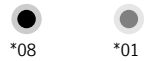

** Bei Bestellung benötigen wir den Durchmesser der Befestigungsbohrungen der Originalgabelbrücke für die korrekte Auswahl der Teile.

** With your order, we need the diameter of the drill holes of the original top yoke for choosing the correct parts.

Superbike sets (**)

Gerade mit Adapter und Rondelle

Straight with adapter and rondel

Art.-Nr./ art. no.	A	B	C	Ø D	X	E	F	G
ME1-08 ME1-01	20mm	54mm	20mm	Ø 22mm	48mm	19,5mm	54mm	20mm
ME2-08 ME2-01	30mm	54mm	20mm	Ø 22mm	58mm	19,5mm	54mm	20mm
ME3-08 ME3-01	40mm	54mm	20mm	Ø 22mm	68mm	19,5mm	54mm	20mm
ME4-08 ME4-01	50mm	54mm	20mm	Ø 22mm	78mm	19,5mm	54mm	20mm



Superbike Sets

Gekröpft mit Adapter und Rondelle

Cranked with adapter and rondel

MF Ø 22mm 30°

Dieses Set besteht aus einem Paar Lenkerklemmböcken aus hochfestem Aluminium mit Adapter und Rondelle in 30° gekröpfter Ausführung für Lenkerdurchmesser 22mm, mit Schrauben und Kunststoff-Schraubenabdeckkappen.

Erhältlich in den vier Höhen 69mm, 78mm, 86mm und 95mm in der Farbe Schwarz oder Silber.

Informationen zu den Einzelteilen des Sets auf Anfrage. Ideal für Café-Racer und Classic-Umbauten. Montage auf viele Original-Gabelbrücken möglich – für verbesserten Fahrkomfort.

This set contains a pair of handlebar clamps of high tensile aluminium with adapter and rondel in 30°cranked design for handlebars with 22mm diameter and comes with screws and plastic screw cover caps. Available in heights 69mm, 78mm, 86mm and 95mm in color black or silver.

Further Information about the single parts on demand. Appropriate for Café-Racer and classic conversions. Fit with various original top yokes. Optimize your drive comfort.



Bohrungs $\varnothing Y$
hole $\varnothing Y$

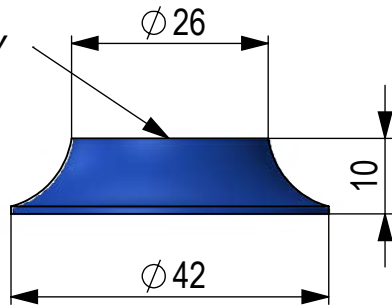

Rondelle / rondel $\varnothing 42$

Art.-Nr./ art. no.	$\varnothing Y$
74-2330110yy*	$\varnothing 10\text{mm}$
74-2330112yy*	$\varnothing 12\text{mm}$

●
*08

●
*01

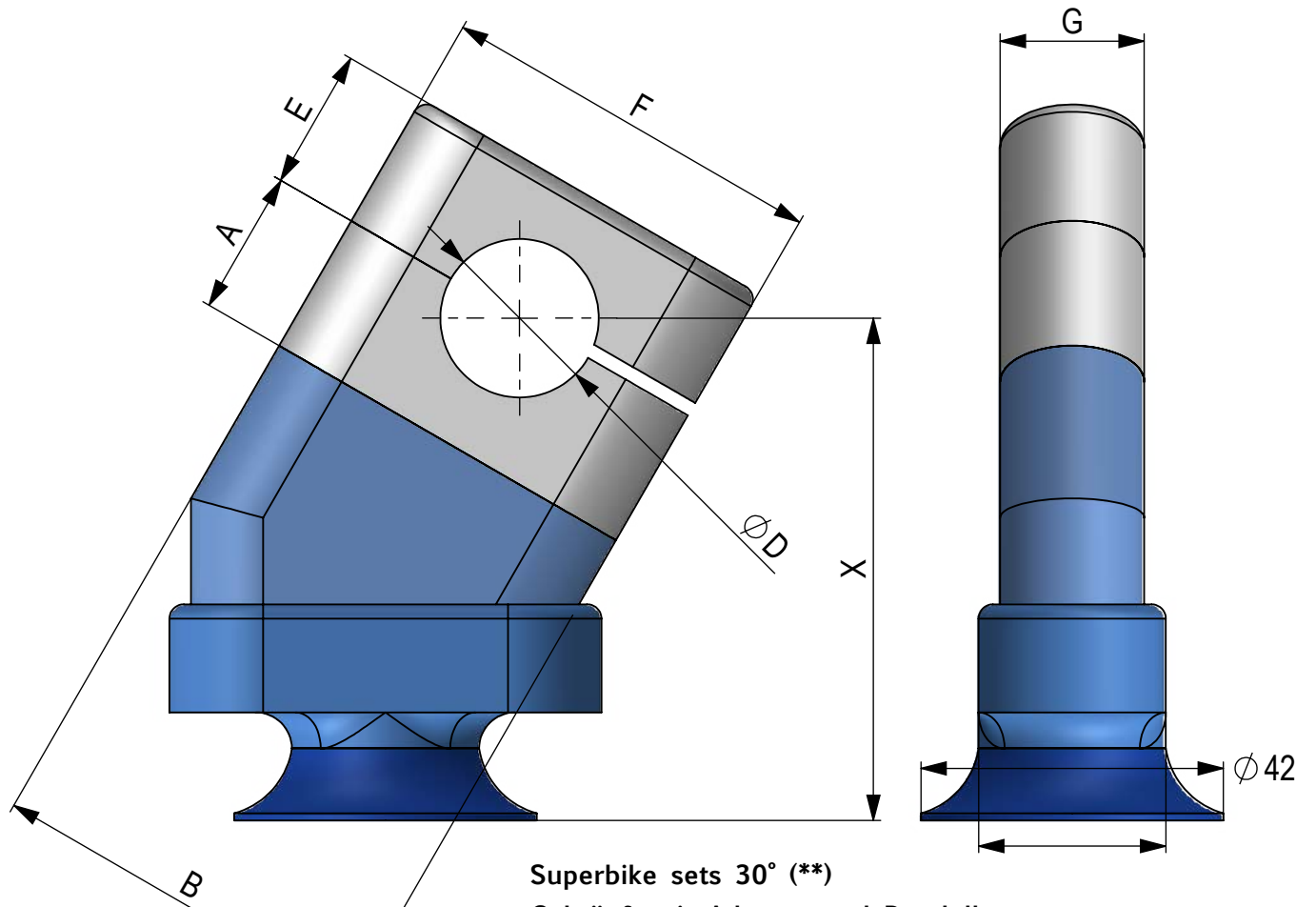

Superbike sets 30° (**)

Gekröpft mit Adapter und Rondelle
cranked with adapter and rondel

Art.-Nr./ art. no.	A	B	C	$\varnothing D$	X	E	F	G
MF1-08 MF1-01	20mm	54mm	26mm	$\varnothing 22\text{mm}$	69mm	19,5mm	54mm	20mm
MF2-08 MF2-01	30mm	54mm	26mm	$\varnothing 22\text{mm}$	78mm	19,5mm	54mm	20mm
MF3-08 MF3-01	40mm	54mm	26mm	$\varnothing 22\text{mm}$	86mm	19,5mm	54mm	20mm
MF4-08 MF4-01	50mm	54mm	26mm	$\varnothing 22\text{mm}$	95mm	19,5mm	54mm	20mm

●

●

** Bei Bestellung benötigen wir den Durchmesser der Befestigungsbohrungen der Originalgabelbrücke für die korrekte Auswahl der Teile.

** With your order, we need the diameter of the drill holes of the original top yoke for choosing the correct parts.

BIGbar Sets

Gerade / straight

MG Ø 25,4mm (1")/ 28,5mm

Dieses Set besteht aus einem Paar Lenkerklemmböcken aus hochfestem Aluminium mit Adapter und Rondelle in gerader Ausführung für Lenkerdurchmesser 28,5mm (BIGbar-Lenker) oder 25,4mm (1"-Lenker) mit Schrauben und Kunststoff-Schraubenabdeckkappen.

Erhältlich in den Höhen 58mm, 68mm, 78mm und 88mm (BIGbar-Lenker) oder 68mm und 88mm (1"-Lenker) in der Farbe Schwarz oder Silber.

Informationen zu den Einzelteilen des Sets auf Anfrage. Ideal für Café-Racer und Classic-Umbauten. Montage auf viele Original-Gabelbrücken möglich – für verbesserten Fahrkomfort.

This set contains a pair of handlebar clamps of high tensile aluminium with adapter and rondel in straight design for handlebars with 28,5mm (BIGbar-handlebar) or 25,4mm (1"-handlebar) and comes with screws and plastic screw cover caps.

Available in heights 58mm, 68mm, 78mm und 88mm (BIGbar-handlebar) or 68mm and 88mm (1"-handlebar) in color black or silver.

Further Information about the single parts on demand. Appropriate for Café-Racer and classic conversions. Fit with various original top yokes. Optimize your drive comfort.



MG3-08

MG4-08



MG1-08



MG2-08

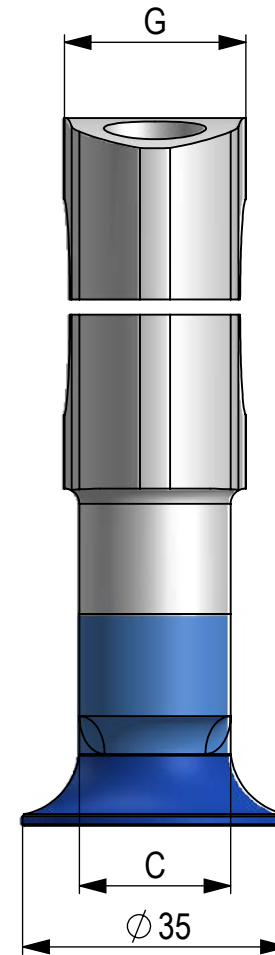
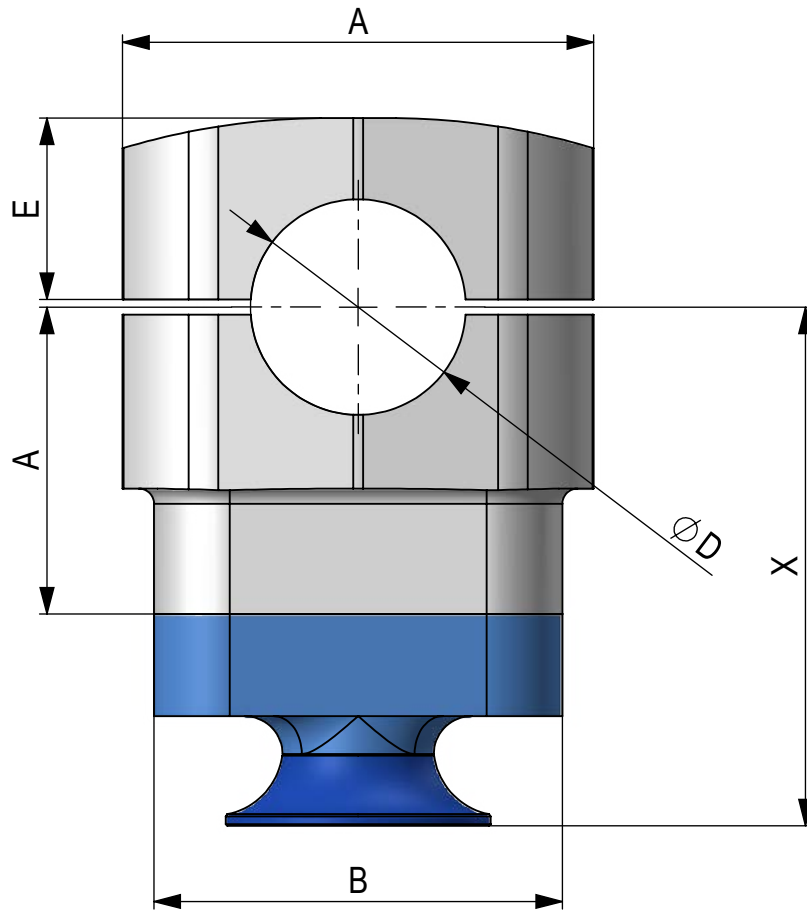

* Bei Bestellung benötigen wir den Durchmesser der Befestigungsbohrungen der Originalgabelbrücke für die korrekte Auswahl der Teile.

* With your order, we need the diameter of the drill holes of the original top yoke for choosing the correct parts.

BIGbar Sets gerade / straight (*)

Art.-Nr./ art. no.	A	B	C	Ø D	X	E	F	G
MG5-08 MG5-01	40mm	54mm	20mm	Ø 25,4mm (1")	68mm	24mm	62mm	24mm
MG6-08 MG6-01	60mm	54mm	20mm	Ø 25,4mm (1")	88mm	24mm	62mm	24mm



Art.-Nr./ art. no.	A	B	C	Ø D	X	E	F	G
MG1-08 MG1-01	30mm	54mm	20mm	Ø 28,5mm	58mm	24mm	62mm	24mm
MG2-08 MG2-01	40mm	54mm	20mm	Ø 28,5mm	68mm	24mm	62mm	24mm
MG3-08 MG3-01	50mm	54mm	20mm	Ø 28,5mm	78mm	24mm	62mm	24mm
MG4-08 MG4-01	60mm	54mm	20mm	Ø 28,5mm	88mm	24mm	62mm	24mm



BIGbar Sets

Gekröpft mit Adapter und Rondelle

Cranked with adapter and rondel

MH Ø 25,4mm (1")/ 28,5mm

Dieses Set besteht aus einem Paar Lenkerklemmböcken aus hochfestem Aluminium mit Adapter und in 30° gekröpfter Ausführung für Lenkerdurchmesser 28,5mm (BIGbar-Lenker) oder 25,4mm (1"-Lenker) mit Schrauben und Kunststoff-Schraubenabdeckkappen. Erhältlich in den Höhen 79mm, 87mm, 96mm und 104mm (BIGbar-Lenker) oder 87mm und 104mm (1"-Lenker) in der Farbe Schwarz oder Silber. Informationen zu den Einzelteilen des Sets auf Anfrage. Ideal für Café-Racer und Classic-Umbauten. Montage auf viele Original-Gabelbrücken möglich - für verbesserten Fahrkomfort.

This set contains a pair of handlebar clamps of high tensile aluminium Rondelle with adapter and rondel in 30° cranked design for handlebars with 28,5mm (BIGbar-handlebar) or 25,4mm (1"-handlebar) and comes with screws and plastic screw cover caps. Available in heights 79mm, 87mm, 96mm and 104mm (BIGbar-handlebar) or 87mm and 104mm (1"-handlebar) in color black or silver. Further Information about the single parts on demand. Appropriate for Café-Racer and classic conversions. Fit with various original top yokes. Optimize your drive comfort.



MH3-08



MH4-08



MH1-08



MH2-08

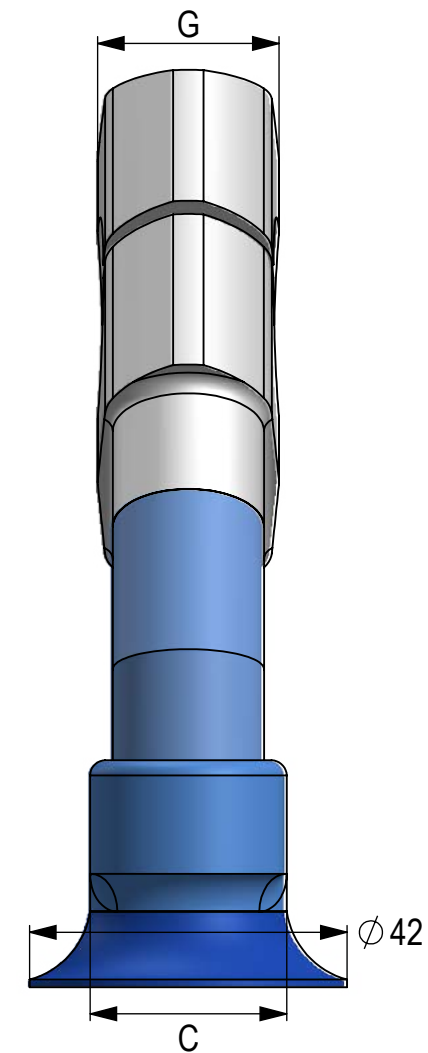
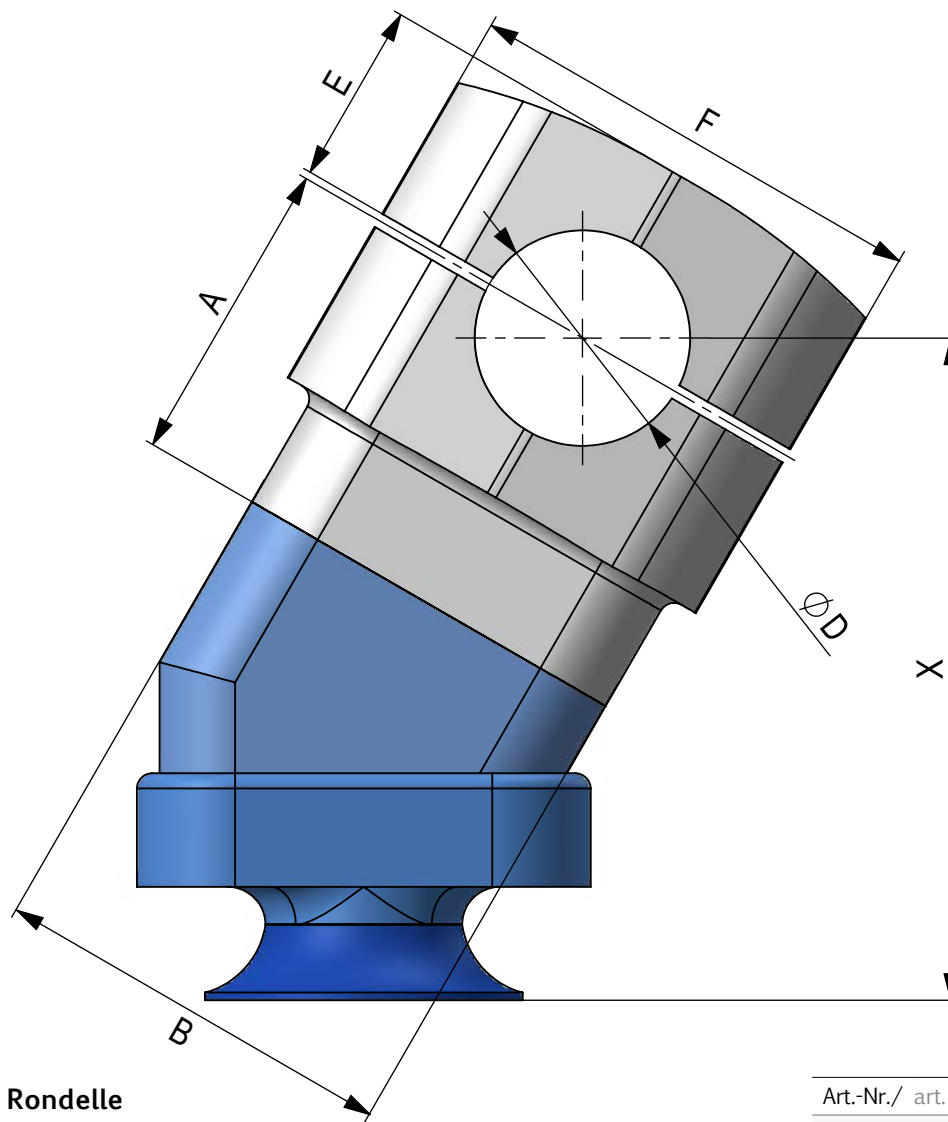

* Bei Bestellung benötigen wir den Durchmesser der Befestigungsbohrungen der Originalgabelbrücke für die korrekte Auswahl der Teile.

* With your order, we need the diameter of the drill holes of the original top yoke for choosing the correct parts.

BIGbar sets 30° (*)
Gekröpft mit Adapter und Rondelle
cranked with adapter and rondel

Art.-Nr./ art. no.	A	B	C	Ø D	X	E	F	G
MH5-08 MH5-01	40mm	54mm	26mm	Ø 25,4mm (1")	87mm	24mm	62mm	24mm
MH6-08 MH6-01	60mm	54mm	26mm	Ø 25,4mm (1")	104mm	24mm	62mm	24mm

Art.-Nr./ art. no.	A	B	C	Ø D	X	E	F	G
MH1-08 MH1-01	30mm	54mm	26mm	Ø 28,5mm	79mm	24mm	62mm	24mm
MH2-08 MH2-01	40mm	54mm	26mm	Ø 28,5mm	87mm	24mm	62mm	24mm
MH3-08 MH3-01	50mm	54mm	26mm	Ø 28,5mm	96mm	24mm	62mm	24mm
MH4-08 MH4-01	60mm	54mm	26mm	Ø 28,5mm	104mm	24mm	62mm	24mm



Lenkererhöhungen Handlebar riser

Wir bieten zwei Möglichkeiten für die Lenkererhöhungen an.

Beide Artikel bestehen aus hochfestem Aluminium und sind wahlweise für die Erhöhung von Lenkern mit den Durchmessern 22mm, 25,4mm (1"), 28,5mm oder 32mm und erhältlich.

Informationen zu den Einzelteilen des Sets auf Anfrage.

Our handlebars risers come in two versions.

Both parts are made of high tensile aluminium and are available for handlebar diameters of 22mm, 25,4mm (1"), 28,5mm or 32mm.

Information about the single parts on demand.

Lenker-Kompletterhöhung 29mm als Paar, in den Farben Schwarz oder Silber, mit MOTACC-Oberteil Schrauben und Schraubenabdeckkappen.

Complete Handlebar Riser 29mm as a pair, in colors black or silver, including the MOTACC top clamps, our screws and screw caps.

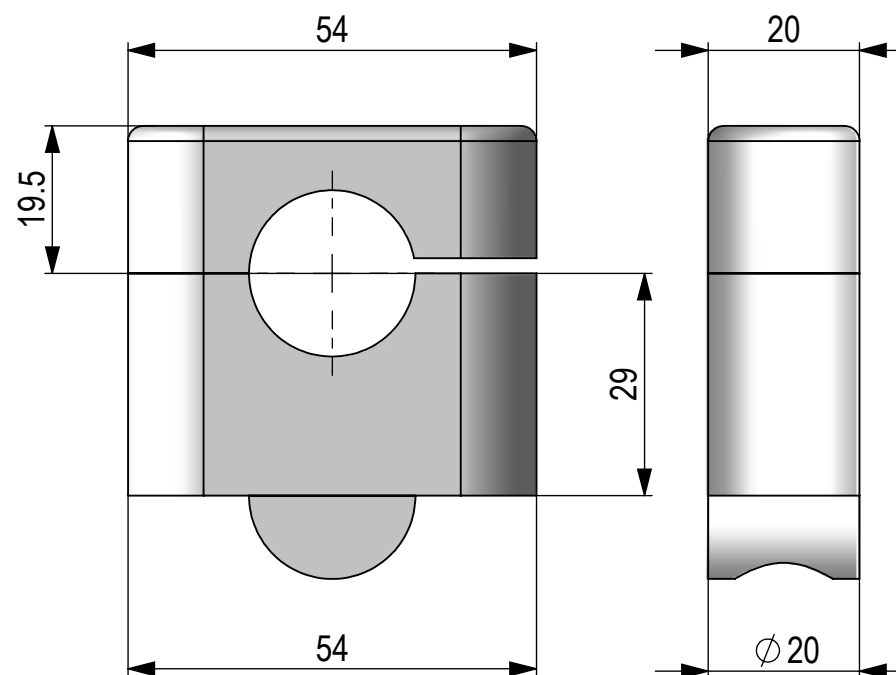

Lenker-Kompletterhöhung (*) Complete Handlebar riser

Art.-Nr./	art. no.	Ø D
MK222-08	MK222-01	Ø 22mm
MK252-08	MK252-01	Ø 25.4mm (1")
MK282-08	MK282-01	Ø 28,5mm
MK322-08	MK322-01	Ø 32mm



Lenkererhöhung 29mm als Paar, in den Farben Schwarz oder Silber, für die Verwendung mit dem Originalober-
 teil und dazu bestellten Schrauben und Schraubenab-
 deckkappen. Durch die Verwendung von Längslöchern
 passend auf viele Original-Klemmböcke.

Handlebar Riser 29mm as a pair, in colors black or
 silver, for the use of the original top clamp with our
 MOTACC screws and screw caps. They are fitting with
 various original clamps, due to longitudinal holes.



* Wenn das Original-Oberteil weiterhin verwendet wird, geben Sie
 bitte bei der Bestellung von Lenkererhöhungen an, ob Sie Schrau-
 ben benötigen oder nicht. Wenn Sie Schrauben benötigen, brau-
 chen wir den Bohrlochdurchmesser auf der Gabelbrücke und ob
 es Senkkopf- oder Zylinderkopfschrauben sind sowie die Länge der
 Originalschrauben.

* If the original top clamps will be used further, please indicate
 with your riser-order whether you need MOTACC screws or not. If
 you need screws, we need the diameter of the drill holes in the
 brace and whether counter-sunk screws or cylinder head screws
 are used - as well as the length of the original screws.

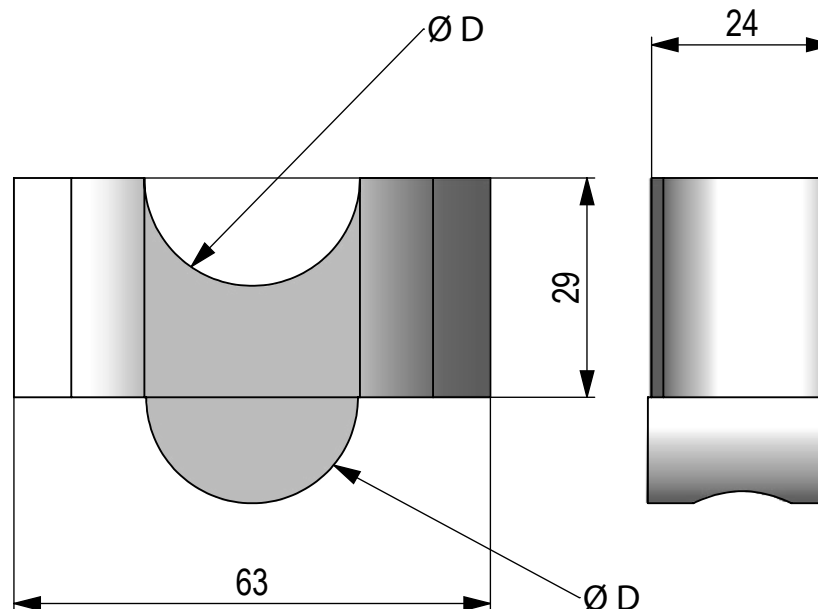

Lenkererhöhung (*) Handlebar riser

Art.-Nr./	art. no.	Ø D
MK22-08	MK22-01	Ø 22mm
MK25-08	MK25-01	Ø 25.4mm (1")
MK28-08	MK28-01	Ø 28,5mm
MK32-08	MK32-01	Ø 32mm



BIGbar **Zwischenstück** **Spacer**

Mit den Zwischenstücken kann der Lenkerklemmbock für Lenker mit 28,5mm Durchmesser unterschiedlich erhöht werden.

Der Artikel ist aus hochfestem Aluminium hergestellt und wird im Paar in der Farbe Schwarz oder Silber in den Höhen 6mm, 10mm oder 20mm geliefert. Je nach Erhöhung und Lenkerklemmbock werden unterschiedliche Schrauben benötigt (nicht im Lieferumfang enthalten).

Wenn Schrauben gewünscht werden, bitte Länge und Typ angeben. Die Schrauben werden mit Schraubenabdeckkappen geliefert.

Informationen zu den Einzelteilen auf Anfrage.

Our spacers help to rise the handlebar of 28,5mm diameter in several steps.

The parts are made of high tensile aluminium and come as a pair in color black or silver and in the height of 6mm, 10mm or 20mm.

According to the height of the handlebar clamps, different screws are used. If screws are needed, please indicate type and length of the screw. Delivery includes screw caps.

Information about the single parts on demand.



74-233342008



74-2330010-08



74-2330006-08

Paar / pair Ø 8mm
74-44208008



Paar / pair Ø 10mm
74-44210008



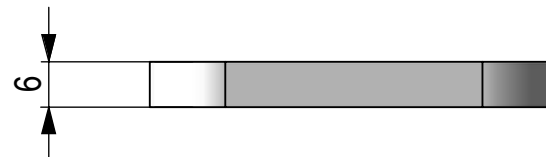
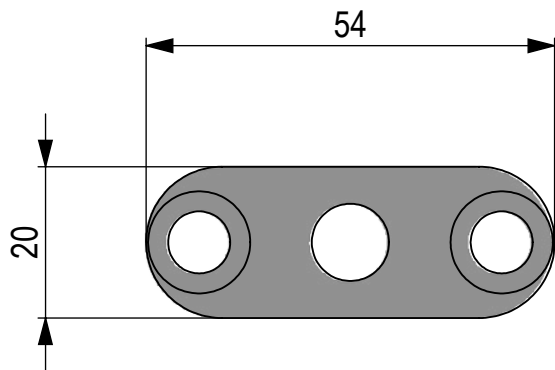
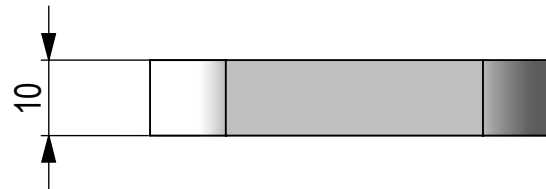
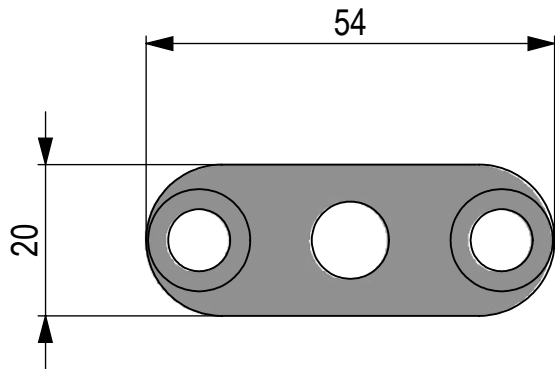
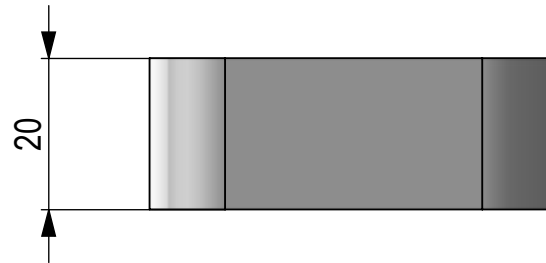
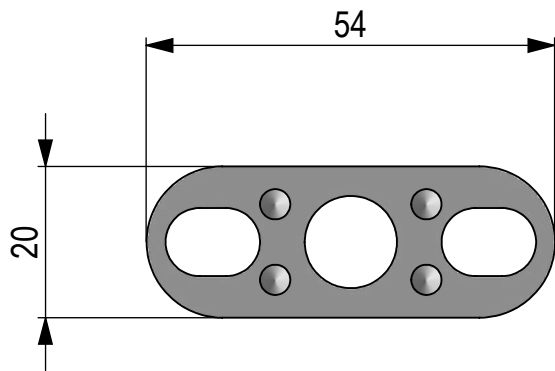

Einzelsschrauben single screws

Schrauben DIN 912, verzinkt, M8 Screws DIN 912, galvanized, M8

Art.-Nr. art. no.	Bezeichnung description
30-191208025	M8x25
30-191208030	M8x30
30-191208035	M8x35
30-191208040	M8x40
30-191208045	M8x45
30-191208050	M8x50
30-191208055	M8x55
30-191208060	M8x60
30-191208065	M8x65
30-191208070	M8x70
30-191208075	M8x75
30-191208080	M8x80
30-191208090	M8x90
30-191208110	M8x110
30-191208130	M8x130

Schrauben DIN 912, verzinkt, M10 Screws DIN 912, galvanized, M10

30-191210030	M10x30
30-191210040	M10x40
30-191210045	M10x45
30-191210050	M10x50
30-191210060	M10x60
30-191210070	M10x70
30-191210080	M10x80
30-191210090	M10x90

Andere Schraubendurchmesser und -längen auf Anfrage.
Ask us for further screws.

BIGbar adapter

22mm → 28,5mm

Mit den universellen BIGbar Adaptern können Lenker mit einem Durchmesser von 28,5mm einfach auf Lenkerhalterungen mit einem Durchmesser von 22mm montiert werden und erhöhen den Lenker um 23mm. Der Lochabstand für die Verschraubung beträgt 33mm. Der Artikel ist aus hochfestem Aluminium hergestellt und wird im Paar in der Farbe Schwarz oder Silber, mit Schrauben 25mm und Schrauben-Abdeckkappen geliefert.

Informationen zu den Einzelteilen auf Anfrage.

With the universal BIGbar handlebar adapter it is easy to mount handlebars of diameter 28,5mm on handlebar holders of diameter 22mm - raising the bar by 23mm.

The distance between the screws is 33mm.

The parts are made of high tensile aluminium and come as a pair in color black or silver with screws of 25mm and screw caps.

Information about the single parts on demand.



74-2060117-08

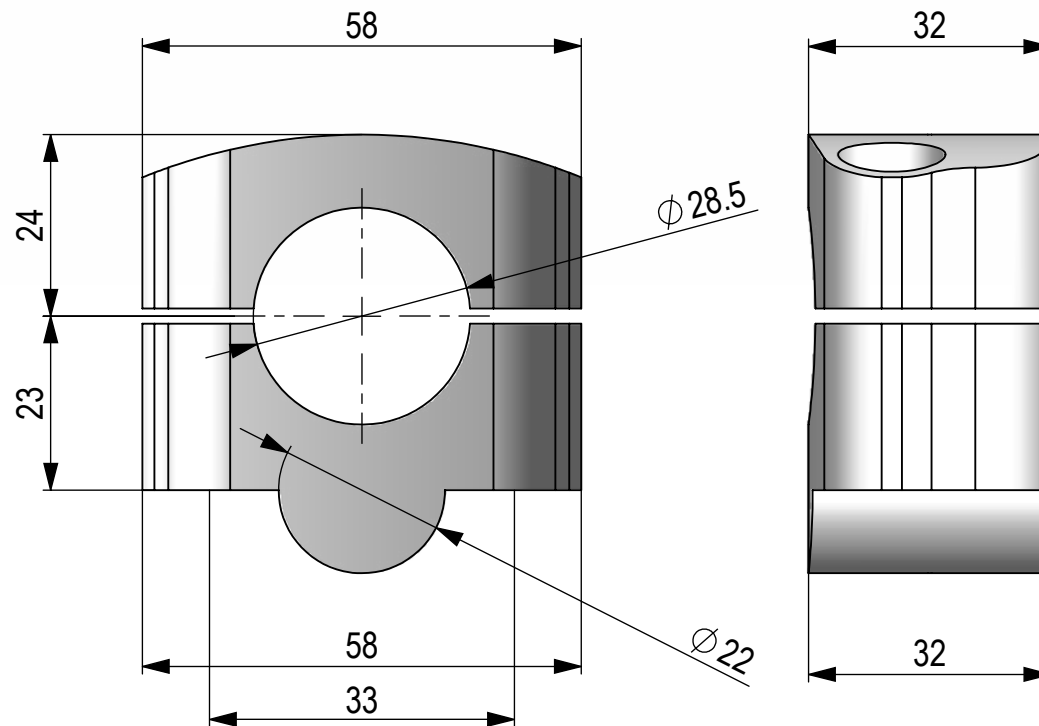

Lochabstand
distance between screws



BIGbar Erhöhung **BIGbar riser**

Honda® CB1000 R/RA

Mit dieser BIGbar Spezialerhöhung können Lenker mit einem Durchmesser von 28,5 mm einfach auf die Original-Lenkerhalterungen des Motorrades montiert werden und erhöhen den Lenker um 20mm.
Der Artikel ist aus hochfestem Aluminium hergestellt und wird im Paar in der Farbe Schwarz oder Silber geliefert.

With this BIGbar special riser it is easy to mount handlebars of diameter 28,5mm on the original handlebar holders of the bike – raising the bar by 20mm.
The parts are made of high tensile aluminium and come as a pair in color black or silver.

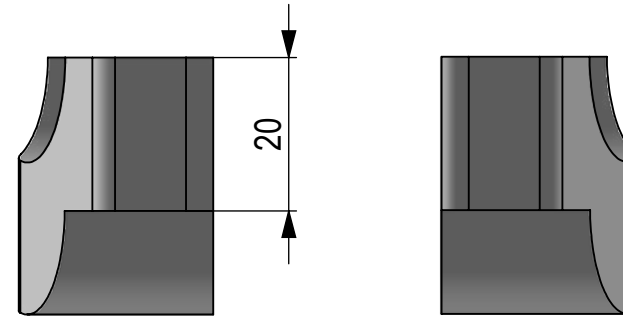

Paar / pair
74-2050130-08

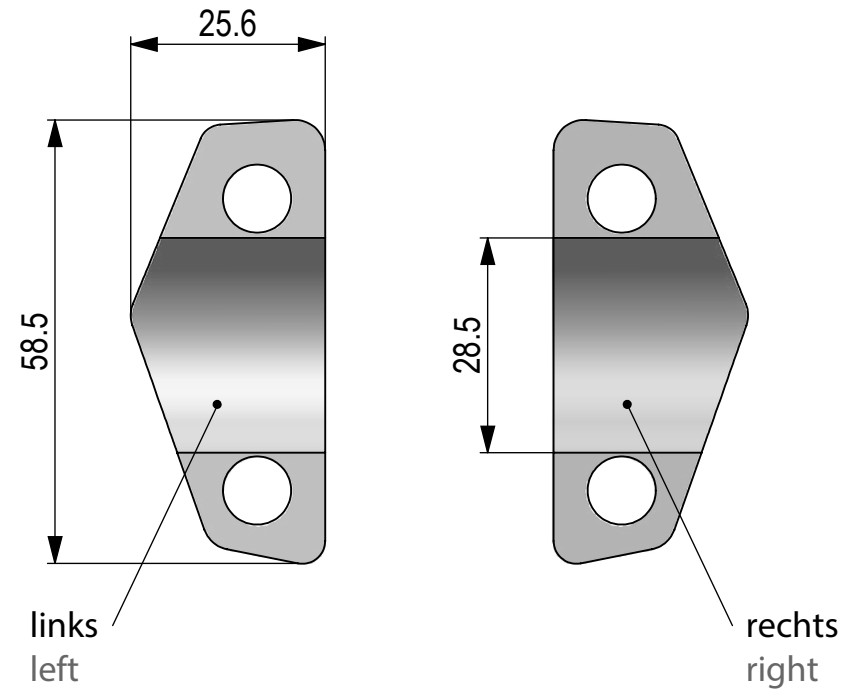

Lenkererhöhungen Spezial Handlebar riser specials

Der Artikel ist aus hochfestem Aluminium hergestellt und wird im Paar in der Farbe Schwarz oder Silber geliefert.

Informationen zu den Einzelteilen auf Anfrage.

MOTACC produziert Lenkererhöhungen für verschiedene Modelle. Fragen Sie uns für Ihre Bedürfnisse an.

The parts are made of high tensile aluminium and come as a pair in color black or silver.

Information about the single parts on demand.

MOTACC is manufacturing risers for different models.

Ask us for special needs.



70-2501001
Passend zu / Suitable for
BMW® Modell HP2*

*Kein Originalteil, passend für BMW
Non-genuine parts, suitable for BMW



70-201200-01
Passend zu / Suitable for
Kawasaki® Modell GTR 1400

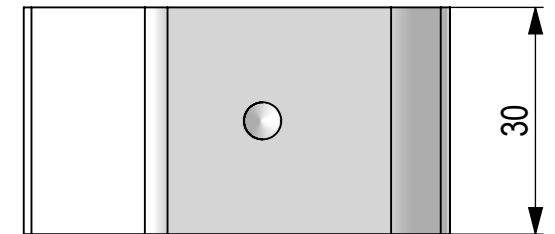
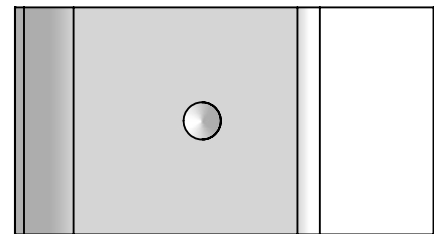
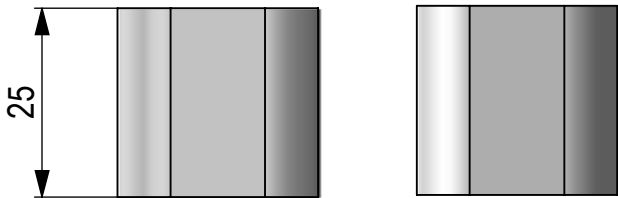
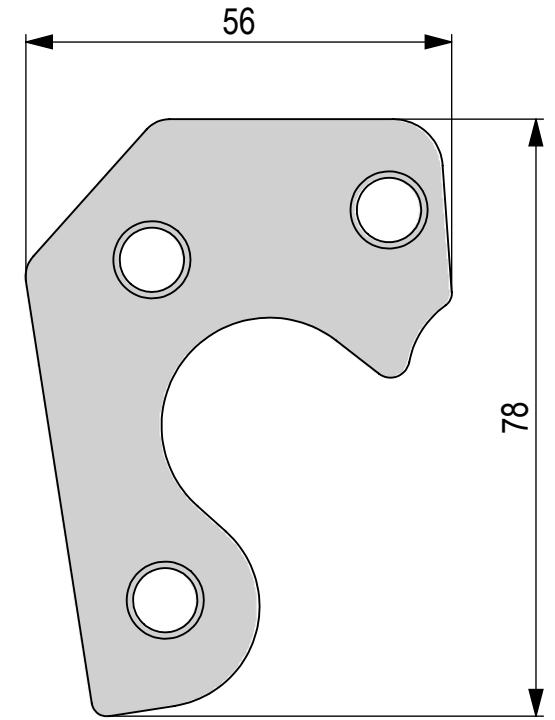
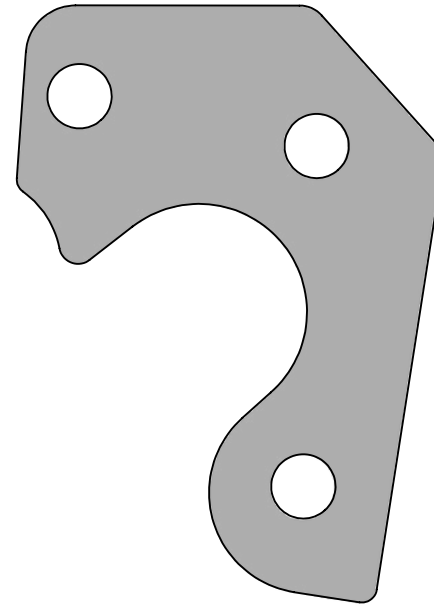
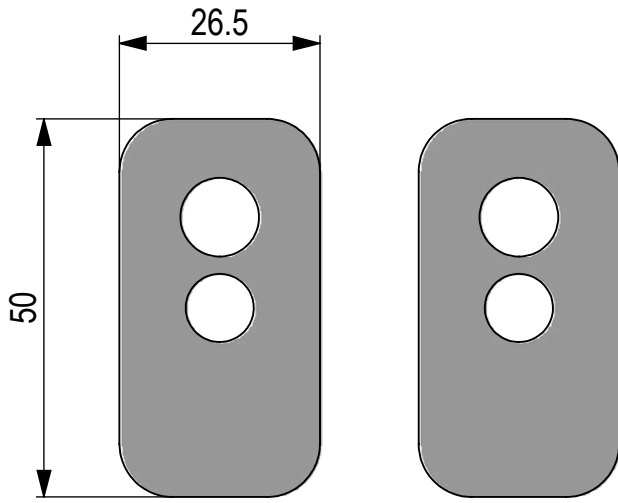

MOTACC Vario Riser

MV Ø 22mm/ 25,4mm (1")/ 28,5mm

Mit dem universellen MOTACC Vario Riser können verschiedene Sitzpositionen stufenlos und einfach eingestellt werden.

Der MOTACC Vario Riser besteht aus dem Socketteil (in der Zeichnung blau eingefärbt), das mit dem passenden Lenkerdurchmesser auf der originalen Lenkerhalterung montiert wird.

Als Oberteil können MOTACC Lenkerklemmböcke verwendet werden (nicht im Lieferumfang enthalten, siehe Seiten 7 (MA) und 9 (MC).

Der Rest ist Einstellungssache!

Im Lieferumfang ist der Socketteil aus hochfestem Aluminium im Paar, in der Farbe Schwarz oder Silber enthalten. Die erhältlichen Lenkerdurchmesser sind 22mm, 25,4mm und 28,5mm.

Informationen zu den Einzelteilen auf Anfrage.

Adjust your seating position continuously variable with the universal MOTACC Vario Riser.

The MOTACC Vario Riser consists of the socket (blue in the drawing), which will be mounted with the fitting handlebar diameter to the original handlebar holder. For the top, MOTACC handlebar clamps are used (not included, see pages 7 (MA) and 9 (MC).)

The rest is finetuning!

The article includes a pair of high tensile aluminium sockets in color black or silver, for handlebar diameters of 22mm, 25,4mm or 28,5mm.

Information about the single parts on demand.



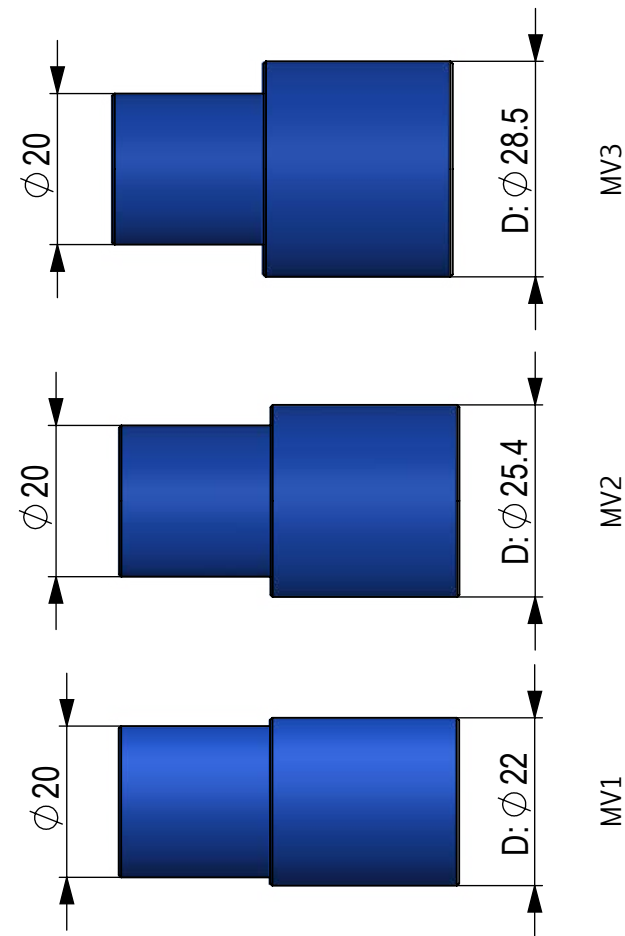
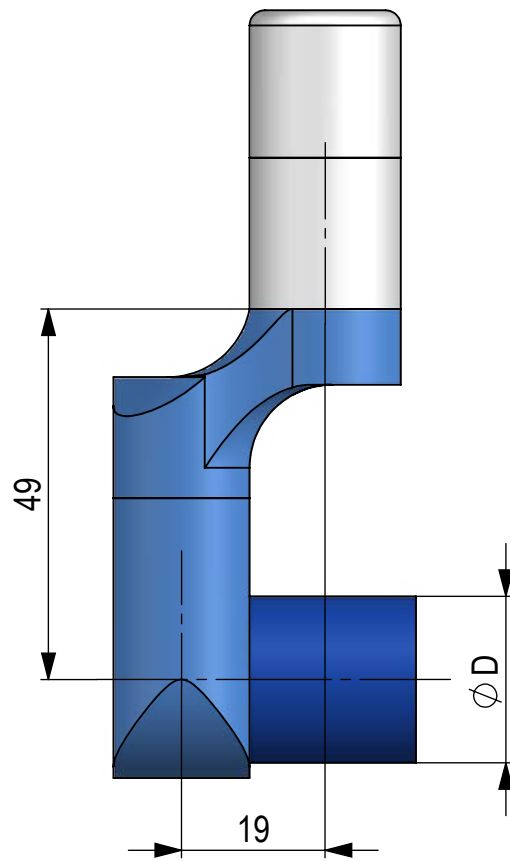
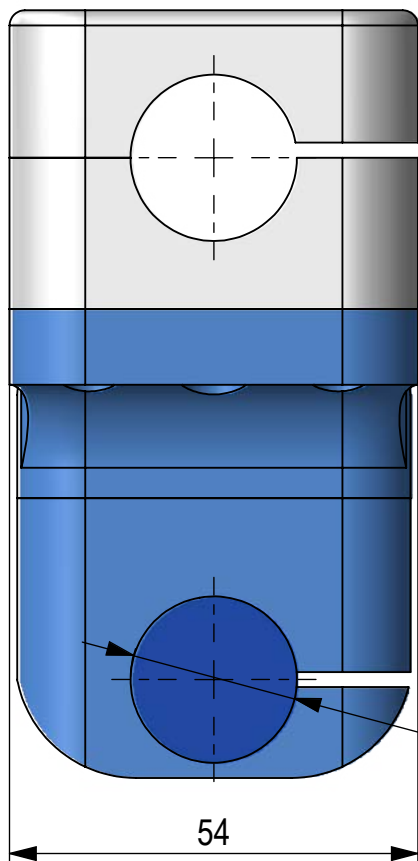

Vario Riser

Art.-Nr./	art. no.	MOTACC Lenker /	Handlebar
MV1-08	MV1-01	Superbike	$\varnothing 22\text{mm}$
MV2-08	MV2-01	FLATbar	$\varnothing 25,4\text{mm}$
MV3-08	MV3-01	BIGbar	$\varnothing 28,5\text{mm}$



Gas & Chokezüge Throttle & choke cables

Alle MOTACC Kabelzüge besitzen einzigartige Leichtlaufeigenschaften. Es werden verschiedene Vorgehensvarianten angeboten:

- Für die unten aufgeführten Modelle sind Gas-/Choke-Züge als Set in einer Superbikevariante erhältlich.
- Neben den unten aufgeführten Modellen fertigen wir Züge nach Maß als Einzel- oder Doppelzug an. Bitte senden Sie uns dazu Ihren Originalzug mit Angabe der gewünschten Änderung (Kürzen oder Verlängern) und Längendaten (Siehe Fol-geseite).
- Alle Einzelkomponenten können bei uns gekauft und die Nippel mit dem Zusatz zu unserem hydraulischen Bördelwerkzeug verpresst werden (siehe Seite 50).
Zusätzlich bieten wir Kits für die Verlängerung der originalen Gas-/Choke-Kabel zum Selberma-chen an (siehe Seite 21).
Weitere Sonderanfertigungen auf Anfrage.

All MOTACC cables are smooth running cables. There are different solutions for throttle and choke cables:

- Throttle cables are available as superbike versions for the following models.
- We also produce throttle cables by sample for single or double versions. Therefore we need the original cable and the designated change (shorten or extend) and the measures (see fol-lowing page too).
- Every single component can be ordered from us. The nipples can be pressed with our compressing tool (see page 50).
In addition, we offer extension kits for original throttle and choke cables for do it yourself application (see page 21).
Further special requirements on demand.

Drei-Dorn Spreizzange
Spreader forceps
95-410132



Gummitülle
Grommet
15-201062



Ø5mm
15-5106043
Ø6mm
15-5206043



Ø5x25mm
15-5107030
Ø6x25mm
15-5207030



Schrumpflebeschlauch
Heat shrink tube sticky
Ø9mm
15-1000060



Ø5mm
15-3100360
Ø6mm
15-3200360

Einzelkomponenten für Werkstätten
Single components for workshops

-  Löt-nippel / Soldering nipple
-  Press-nippel

Gaszugset Superbike
Throttle cable set superbike



Art.-Nr. art. no.	ME qu	Modelle model
74-5441032001	Paar / pair	VFR 750 (90-93)
74-5441032002	Paar / pair	VFR 750 (94-)
74-5441052001	Paar / pair	CBR 1100XX ()
74-5441202101	Paar / pair	VTR 1000 SP1 (00-01)
74-5443131002	Paar / pair	TL 1000R (98)
74-5443142001	Paar / pair	GSX-R 1300 Hayab. (99-07)
74-5443151001	Paar / pair	GSX-R 750 (00-03)
74-5443151002	Paar / pair	GSX-R 1000 (01-04)
74-5443161011	Paar / pair	SV 1000S (03-)
74-5443202101	Paar / pair	GSX-R 1000 (07-)
74-5443212101	Paar / pair	GSX-R 1000 (05-06)
74-5443731001	Paar / pair	GSX-R 600 (96-99)
74-5444212001	Paar / pair	YZF - R1 (02-03)
74-5444202001	Paar / pair	YZF - R1 / SP (04-06)
74-5444212002	Paar / pair	YZF - R1 (07-08)
74-5444222001	Paar / pair	YZF - R6 (05)
74-5444202002	Paar / pair	YZF - R6 (06-07)
74-5444202003	Paar / pair	YZF - R6 (08-)
74-5446721001	Stk. / pcs.	K 1200S (04-)
74-5446721002	Stk. / pcs.	K 1200R (05-)
74-5446721003	Paar / pair	K 1300R (09-)
74-5448403101	Paar / pair	748/749/916/996/998 (95-)
74-5449403101	Paar / pair	F4 750S/1000R/S/1078 (99-)



Siehe Seite
See page
50 

Pressbacken
Pressing jaws
95-4100122



-  Ø6x6mm INOX 15-3211030
-  Ø6x8mm INOX 15-3231030



Kupplungszüge

Clutch cables

Es bestehen verschiedene Bestellvarianten für Leichtlauf-Kupplungszüge von MOTACC:

- Für die unten aufgeführten Modelle sind Kupplungszüge als Set in einer Superbikevariante erhältlich.
- Zusätzlich bieten wir Kits für die Verlängerung der originalen Kupplungszüge zum Selbermachen an (siehe Folgeseite).
- Wir fertigen Züge nach Maß an. Bitte senden Sie uns dazu den Originalzug mit Angabe der gewünschten Änderung (Kürzen oder Verlängern) und Längendaten.
- Alle Einzelkomponenten können bei uns gekauft werden (hydraulisches Nippel-Presswerkzeug siehe Seite 50).

All MOTACC cables are smooth running cables. There are different solutions available:

- Clutch cables are available as superbike versions for the following models.
- In addition, we offer extension kits for original clutch cables for do it yourself application (see following page).
- We also produce clutch cables by sample. Therefore we need the original cable and the change needed (shorten or extend) and the measures.
- Every single component can be ordered from. (hydraulic pressing tool see page 50).



Sonderanfertigung mit Edelstahlgewebe
für Gas- / Choke- und Kupplungszüge auf Anfrage
Custom order with stainless steel mesh
for Throttle / Choke and Clutch cables on demand



Rohrschneider
Tube cutter
95-4100011

Hydraulisches Presswerkzeug
Hydraulic pressing tool
95-5000100

Universal
Ø2x1600mm
15-2300160



Ø7mm
15-5306043



Schrumpfklebeschlauch
Heat shrink tube sticky
Ø9mm
15-1000060



Ø7x25mm
15-5307030



AØ7; IØ3mm
15-2300360
AØ9,5mm
15-2900360



T-Nippel
Ø2x1600mm
15-2243130



Zylinder
Ø2x1600mm
15-2430130
Ø2x3000mm
15-2430230



Superbike Kupplungszüge Superbike clutch cables

Art.-Nr. art. no.	ME qu	Modelle model
74-531050650-00	Stk. / pcs.	CBR 600RR (03-06)
74-531080700-00	Stk. / pcs.	CBR 600RR (07-)
74-531050750-00	Stk. / pcs.	CBR 600 FS (01-02) CBR 900RR (00-01)
74-531000750-00	Stk. / pcs.	CBR 900RR (92-99)
74-531050850-00	Stk. / pcs.	CBR 900RR (02-03)
74-531081200-00	Stk. / pcs.	CBR 1000RR (08-)
74-530970850-00	Stk. / pcs.	ZX 6R (05-06)
74-531121000-00	Stk. / pcs.	ZX 6R (07-08)
74-531000750-00	Stk. / pcs.	ZX 9R (98-99)
74-531000950-00	Stk. / pcs.	ZX 9R (00-01)
74-531140900-00	Stk. / pcs.	ZX 10R (04-05)
74-531051350-00	Stk. / pcs.	ZX 10R (06-07)
74-531051100-00	Stk. / pcs.	ZX 10R (08-)
74-530980900-00	Stk. / pcs.	ZX 12R
74-531231101-00	Stk. / pcs.	GSX-R 600 (06-07)
74-530930800-00	Stk. / pcs.	SV 650 S (-02)
74-531231100-00	Stk. / pcs.	GSX-R 750 (06-07)
74-531320951-00	Stk. / pcs.	GSX-R 1000 (05-06)
74-531241000-00	Stk. / pcs.	YZF 600R YZF-R6 (98-02)
74-531191100-00	Stk. / pcs.	YZF - R6 (03-04)
74-531201050-00	Stk. / pcs.	YZF - R6 (05-07)
74-531241050-00	Stk. / pcs.	YZF - R6 (08-)
74-531001200-00	Stk. / pcs.	TRX 850 (96-00)
74-531201200-00	Stk. / pcs.	YZF - R1 (98-01)
74-531151200-00	Stk. / pcs.	YZF - R1 (02-03)
74-531251100-00	Stk. / pcs.	YZF - R1 / SP (04-06)
74-531331050-00	Stk. / pcs.	YZF - R1 (07-)
74-531020800-00	Stk. / pcs.	Sprint ST 1050 (05)



M8x38mm
15-6664043

Ø6,2; Ø7mm
15-6395043



Ø8,8mm

Ø7mm

15-6374043



Ø8,3mm

Ø7mm

M8x44mm
15-6384043



M8x35
15-6675043

Ø7mm



M8x45mm
15-6685043

Ø7mm

Einzelkomponenten für Werkstätten
Single components for workshops

↳ Löt nipple / Soldering nipple
↳ Press nipple



Ø6x10mm
15-2243050



Ø6x10 INOX
15-2243030



Ø9x12mm
15-2994050



Ø10x12mm
15-2794043



Ø10x12mm
15-2794043

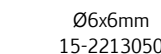

Ø6x6mm
15-2213050

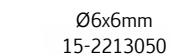

Ø6x6mm
15-2213050



Ø6x6mm
15-2213050

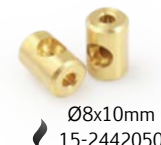

Ø8x10mm
15-2442050

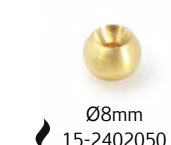

Ø8mm
15-2402050



Ø10mm
15-2702050



Ø8x8mm INOX
15-2432030

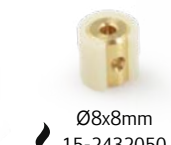

Ø8x8mm
15-2432050



Ø8x8mm
15-2430060

Verlängerungs-Kits ***Extension kits***

Für Gas- und Kupplungszüge
For throttle and clutch cables

Alle MOTACC Kabelzüge besitzen einzigartige Leichtlaufeigenschaften. Für alle Umbauer bieten wir universelle Verlängerungskits für Gas- und Kupplungszüge an. Bei Gaszügen für Einzelzug oder Doppelzug. Die Inhalte des Kits sind nachfolgend aufgeführt.

All MOTACC cables are smooth running cables. We offer a universal extension kit for throttle- and clutch cables to custom shops. Throttle cables are available as a single or double version. The content of the kits is shown in the following lists.



Verlängerungskit für Gaszug

1x Innenzug 1,6m Ø1,3mm
2x Kupferstücke
(zum Körnen)
1x Hülle 20cm
2x Schrumpflebeschlauch
1x Lötnippel

Extensionkit for Throttle cable

1x inner cable 1,6m Ø1,3mm
2x copper piece
(for punch marking)
1x cover 20cm
2x heat shrink tube sticky
1x brazing nipple

Art.-Nr. art. no.	ME qu	Modelle model
----------------------	----------	------------------

Verlängerungskits für Originalzüge **Extensionkit for original cable**

74-548010001-00	Kit	für Einzelzug / for single cable
74-548010011-00	Kit	für Doppelzug / for double cable

Spezialanfertigungen nach Maß/Muster **Custom product by sample**

74-549020001-00	Stk. / pcs.	Gaszug umarbeiten rework throttle cable	Kundenzug eingeschickt + umarbeiten customer's cable sent in + reworked
74-549120001-00	Paar / pair	Gaszugset umarbeiten rework throttle cable set	Kundenzüge eingeschickt + umarbeiten customer's cable sent in + reworked

Verlängerungskit für Kupplungszug

1x Innenzug 1,6m Ø2mm
2x Kupferstücke
(zum Körnen)
1x Hülle 20cm
2x Schrumpflebeschlauch
1x Lötnippel

Extensionkit for Clutch cable

1x inner cable 1,6m Ø2mm
2x copper piece
(for punch marking)
1x cover 20cm
2x heat shrink tube sticky
1x brazing nipple

Art.-Nr. art. no.	ME qu	Modelle model
----------------------	----------	------------------

Verlängerungskits für Originalzüge **Extensionkit for original cable**

74-538010001-00	Kit	Verlängerungskit für Kupplungszüge extensionkit for clutch cables
-----------------	-----	--

Spezialanfertigungen nach Maß/Muster **Custom product by sample**

74-539020001-00	Stk. / pcs.	Kundenzug eingeschickt + verlängert customer's cable sent in + reworked
-----------------	-------------	--

Diverse Anbauteile ***Various mounting parts***



Verkleidungsunterlage
fairing basis



Verkleidungshalter
fairing mount



Halter für Hydraulikflüssigkeitsbeh.
hydraulic fluid reservoir mount



Halter für Lenkungsdämpfer
steering damper mount

Diverse Halter **Various mountings**

Art.-Nr. art. no.	ME qu	Modelle model	Farbe color
----------------------	----------	------------------	----------------

Verkleidungshalter Superbike - pulverbeschichtet **Fairing mount superbike - powder-coated**

74-12110001	Stk. / pcs.	CBR 900 RR 92-97	schwarz / black
74-12110002	Stk. / pcs.	CBR 900 RR 98-99	schwarz / black
74-12120002	Stk. / pcs.	ZX 6 R 98-99	schwarz / black
74-12120003	Stk. / pcs.	ZX 9 R 98-99	schwarz / black

Verkleidungsunterlagen komplett **complete fairing basis**

74-36201000-08	Kit	CBR 1000RR 04-07	schwarz / black
74-36202000-08	Kit	R1 98-99 + 00-01 + 02-03	schwarz / black

Halter für Lenkungsdämpfer **steering damper mount**

74-12200001	Stk. / pcs.	TL 1000S	schwarz / black
74-36300001-08	Stk. / pcs.	ZX 10R / 06-	schwarz / black
74-36300002-01	Stk. / pcs.	YZF - R1 / 04-08	silber / silver

Zubehör **Accessories**

Art.-Nr. art. no.	ME qu	Bezeichnung description	Farbe color
74-36100001-01	Stk. / pcs.	Halter für Hydraulikflüssigkeitsbehälter hydraulic fluid reservoir mount	silber / silver
15-136008	Stk. / pcs.	Bremsflüssigkeitsschlauch $\varnothing 7$ a $\varnothing 12$ (á 20cm) brake fluid tube $\varnothing 7$ a $\varnothing 12$ (á 20cm)	schwarz / black
74-82001001	Kit	Hupenkabelverlängerungskit horn cable extension	schwarz / black



Aluminium Lenker

Aluminium handlebars



Superbike Ø 22mm

MOTACC Aluminium Lenker sind aus hochfestem Aluminium mit sandgestrahlter Oberfläche. Die Lenker sind in verschiedenen Eloxalfarben und Formen erhältlich. Alle Lenker werden mit TÜV-Gutachten bzw. ABE geliefert!

MOTACC aluminium handlebars are made of high-quality aluminium with sandblasted surface. All handlebars are available in different anodized colors. Every handlebar is shipped with TÜV homologation resp. ABE (vehicle operating permit).

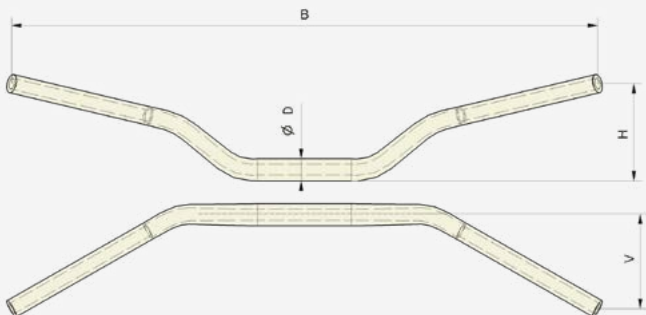

MOTACC S1 - Standard
75-50008



MOTACC S2 - Standard
75-55020



MOTACC S4 - Flat
75-52008











MOTACC S5 - Touring
75-50108



MOTACC Superbike Ø 22mm

Art.-Nr. art. no.	Typ typ	Form shape	Material material	Breite (B) width	Höhe (H) height	Versatz (V) offset	Innen-Ø inside-Ø	Farbe, Farbcode color (code)
75-500yy	Motacc S1	Standard	Aluminium	750mm	110mm	120mm	12 mm	yy
75-55020	Motacc S2	Standard	Stahl	750mm	110mm	120mm	18 mm	Chrom / chrome
75-52001	Motacc S4	Flat	Aluminium	810mm	65mm	64mm	14 mm	Silber / silver
75-52008	Motacc S4	Flat	Aluminium	810mm	65mm	64mm	14 mm	Schwarz / black
75-50101	Motacc S5	Touring	Aluminium	780mm	150mm	120mm	14 mm	Silber / silver
75-50108	Motacc S5	Touring	Aluminium	780mm	150mm	120mm	14 mm	Schwarz / black

								
01	03	04	05	08	09	10	11	14
silber	blau	rot	gruen	schwarz	gold	violett	anthrazit	orange
silver	blue	red	green	black	gold	violet	anthracite	orange

Lenker in folgenden Eloxalfarben
(bitte yy in der Art.-Nr. durch den Farbcode ersetzen).
Handlebar available in different anodized colors
(replace yy in art. no. with color code).

FLATbar Ø 25,4mm (1")

Der MOTACC-FLATbar-Lenker 25,4 wird für Lenkerbefestigungen in Zollmassen verwendet.

Use MOTACC FLATbar 1" handlebar for bikes with inch fixations.



MOTACC FLATbar - Flat
75-58008

MOTACC FLATbar Ø 25,4mm (1")

Art.-Nr. art. no.	Typ typ	Form shape	Material material	Breite (B) width	Höhe (H) height	Versatz (V) offset	Innen-Ø inside-Ø	Farbe color
75-58001	Motacc C4	Flat	Aluminium	810mm	80mm	60mm	17.5 mm	Silber / silver
75-58008	Motacc C4	Flat	Aluminium	810mm	80mm	60mm	17.5 mm	Schwarz / black



BIGbar Ø 28,5mm

Unsere konifizierten 28,5mm BIGbar-Lenker gibt es in drei verschiedenen Kröpfungen. Das Motorrad wirkt mit dem BIGbar-Lenker massiver und kraftvoller. Weitere Eloxalfarben auf Anfrage.

Double butted 28,5mm BIGbar handlebar for a massive and stronger optic of the motorbike. Available in three different shapes. Further anodised colors on demand.

Bohrlehre / Drilling jig



95-415001



MOTACC BIGbar - Standard
75-56008



MOTACC BIGbar - Flat
75-57008



MOTACC BIGbar - Touring
75-89008

MOTACC BIGbar Ø 28,5mm

Art.-Nr. art. no.	Typ typ	Form shape	Material material	Breite (B) width	Höhe (H) height	Versatz (V) offset	Innen-Ø inside-Ø	Farbe color
75-56001	Motacc B1	Standard	Aluminium	760mm	110mm	120mm	14 mm	Silber / silver
75-56008	Motacc B1	Standard	Aluminium	760mm	110mm	120mm	14 mm	Schwarz / black
75-57001	Motacc B4	Flat	Aluminium	810mm	65mm	64mm	14 mm	Silber / silver
75-57008	Motacc B4	Flat	Aluminium	810mm	65mm	64mm	14 mm	Schwarz / black
75-89001	Motacc B5	Touring	Aluminium	780mm	150mm	140mm	14 mm	Silber / silver
75-89008	Motacc B5	Touring	Aluminium	780mm	150mm	140mm	14 mm	Schwarz / black

RAIDbar Ø 32mm



MOTACC RAIDbar* - Touring
75-59508

HEATbar Ø 22mm



MOTACC S1H - Standard**
75-49001

MOTACC RAIDbar Ø 32mm*

Art.-Nr. art. no.	Typ typ	Form shape	Material material	Breite (B) width	Höhe (H) height	Versatz (V) offset	Innen-Ø inside-Ø	Farbe color
75-59501	Motacc R5	Touring	Aluminium	820mm	150mm	140mm	14 mm	Silber / silver
75-59508	Motacc R5	Touring	Aluminium	820mm	150mm	140mm	14 mm	Schwarz / black

MOTACC HEATbar Ø 22mm**

75-49001	Motacc S1H	Standard	Aluminium	750mm	110mm	120mm	12 mm	Silber / silver
----------	------------	----------	-----------	-------	-------	-------	-------	-----------------

(*Passend für neue BMW-Modelle, kein Originalteil / Suitable for latest BMW motorbikes, no genuine part)

(**Passend für BMW-Heizgriffe, kein Originalteil / Suitable for BMW heat grips, no genuine part)

Lenkergewichte Handlebar weights

MOTACC Lenkergewichte werden als verschiedene Typen angeboten: Direktverschraubt oder mit Klemmungen versehen. Die MOTACC-Klemmungen bieten eine optimale Verankerung im Lenker und können beliebig oft gelöst und wieder montiert werden.

Die Lenkergewichte sind auch optimal für die Montage der MOTACC-Lenkerendenspiegel (siehe Seite 27). Zudem sind Spiegel-Kits erhältlich, welche Lenkergewichte und direkt aufschraubbare Spiegel enthalten (siehe Seite 28).

Die Lenkergewichte kommen immer als Paar und sind in verschiedenen Farben erhältlich. Wenn nichts anderes vermerkt, werden die Klemmungen in der gewünschten Größe zusätzlich bestellt. Sonderfarben auf Anfrage.

MOTACC handlebar weights are available in different types: directly screwed into the inner pipe of the handlebar or with an efficient cotter system. They are perfectly suited for the use of MOTACC superbike handlebar mirrors as well (see page 27). In addition, you can choose from different mirror kits, which contain fitting handlebar weights as well (see page 28). The handlebar weights come always in pairs and in different colours. The cotter have to be ordered additionally in the specific size. Special colors on demand.

*Lenkergewichte in den folgenden Eloxalfarben (bitte yy in der Art.-Nr. durch den Farbcode ersetzen).

*Handlebar weights available in different anodized colors (replace yy in art. no. with color code).



mit M8 Schraube
with M8 screw



75-1922yy*

01	03	04	05	08	09	11
silber	blau	rot	gruen	schwarz	gold	anthrazit
silver	blue	red	green	black	gold	anthracite



Africa
Twin



75-1914yy*

01	08	09	11
silber	schwarz	gold	anthrazit
silver	black	gold	anthracite



75-1830001



75-1910001



12mm
75-1801208



14mm
75-1911418



Unsere Spiegel:
Our mirrors:
Seiten / pages 27-28

Typ MO

Art.-Nr. art. no.	ME qu	Klemmung cotters	Farbe colour
----------------------	----------	---------------------	-----------------

MO2 Lenkergewichte mit Klemmung Handlebar weights with cotters

75-18012yy	Paar / pair	12mm	yy
75-18014yy	Paar / pair	14mm	yy
75-18016yy	Paar / pair	16mm	yy
75-18017yy	Paar / pair	17mm	yy
75-18018yy	Paar / pair	18mm	yy
75-18021yy	Paar / pair	21mm	yy

MO1 Lenkergewichte ohne Klemmung Handlebar weights without cotters

75-18300yy	Paar / pair	-	yy
------------	-------------	---	----

20	01	03	04	05	08	09	11
chrom	silber	blau	rot	gruen	schwarz	gold	anthrazit
chrome	silver	blue	red	green	black	gold	anthracite

Typ ML mit Fräsung / milled

Art.-Nr. art. no.	ME qu	Klemmung cotters	Farbe colour
----------------------	----------	---------------------	-----------------

ML2 Lenkergewichte mit Klemmung Handlebar weights with cotters

75-19112yy	Paar / pair	12mm	yy
75-19114yy	Paar / pair	14mm	yy
75-19116yy	Paar / pair	16mm	yy
75-19117yy	Paar / pair	17mm	yy
75-19118yy	Paar / pair	18mm	yy
75-19121yy	Paar / pair	21mm	yy

ML1 Lenkergewichte ohne Klemmung Handlebar weights without cotters

75-19100yy	Paar / pair	-	yy
------------	-------------	---	----

18	01	03	04	08	09	11
silber - schwarz	silber	blau	rot	schwarz	gold	anthrazit
silver - black	silver	blue	red	black	gold	anthracite



Klemmungen Cotters

Beim Anziehen der Schraube verschieben sich die beiden Klemmkeile der MOTACC-Klemmungen gegeneinander und verkeilen sich großflächig im Innenrohr des Lenkers. Dies garantiert auch nach mehrmaligem Aus- und Wiedereinbauen einen festen Sitz. Die Klemmungen sind für die üblichen unterschiedlichen Lenker-Innendurchmesser erhältlich. Bei der Bestellung muss deshalb die notwendige Größe angegeben werden. Die Klemmungen werden immer als Paar mit Klemmkeilen und Schrauben geliefert.

Screwed into the inner pipe of the handlebar, the MOTACC cotters expand and guarantee an exact fit even after repeated mounting and demounting. The cotters are available for handlebars with different interior diameters. Please indicate the right size with an order. They are shipped in pairs with cotters and screws.



Ø21 Ø18 Ø17 Ø16 Ø14 Ø12 Adapter für / for BMW*
75-1840112

Klemmungen (mit Schrauben) Cotters (incl. screws)

Art.-Nr. art. no.	ME qu	Klemmung cotters
75-1820012	Paar	Ø 12mm
75-1820014	Paar	Ø 14mm
75-1820016	Paar	Ø 16mm
75-1820017	Paar	Ø 17mm
75-1820018	Paar	Ø 18mm
75-1820021	Paar	Ø 21mm
75-1840112	Paar	M12 A Ø M6 I Ø

Lenkerverbreiterung Handlebar extension

Mit Hilfe der MOTACC Lenkerverbreiterung lässt sich der Lenker einfach um 4-7cm verbreitern. Dies ermöglicht etwa die Montage von Lenkerendspiegeln ohne das Versetzen der Armaturen. Mit den MOTACC Klemmungen ist optimaler Halt garantiert und die Verlängerung kann beliebig oft montiert und wieder gelöst werden. Besonders interessant ist auch die spezielle Version für die Montage von BMW* Heizgriffen!

MOTACC handlebar extensions are an easy opportunity to extend your handlebars for 4-7cm, which e.g. allows to mount handlebar end mirror arms without moving the grips. They offer an optimal halt with their cotter system. Particularly interesting is the special version for mounting BMW* heat grips!



M6 kurz / short
20mm



M6 lang / long
35mm



Lenkerverbreiterung für BMW*
Handlebar heating for BMW*

Lenkerverbreiterung / Handlebar extension

Art.-Nr. art. no.	ME qu	Bezeichnung description	Breite width
75-501220	Paar / pair	Lenkerverbreiterung inkl. Klemmung für 12mm Innendurchmesser Handlebar extension incl. cotters for 12mm interior diameter	20mm
75-501420	Paar / pair	Lenkerverbreiterung inkl. Klemmung für 14mm Innendurchmesser Handlebar extension incl. cotters for 14mm interior diameter	20mm
75-501235	Paar / pair	Lenkerverbreiterung inkl. Klemmung für 12mm Innendurchmesser Handlebar extension incl. cotters for 12mm interior diameter	35mm
75-501435	Paar / pair	Lenkerverbreiterung inkl. Klemmung für 14mm Innendurchmesser Handlebar extension incl. cotters for 14mm interior diameter	35mm
75-61235	Paar / pair	Lenkerverbreiterung für BMW Heizgriffe inkl. Klemmung, 12mm Innendurchmesser Handlebar extension for BMW heat grips incl. cotters for 12mm interior diameter	35mm

Bremsschutzbügel ***Brake lever guard***

Der verstellbare MOTACC Bremsschutzbügel kann mit oder ohne Lenkergewicht montiert werden. Er wird schwarz, mit der Klemmung in der gewünschten Größe des Lenker-Innendurchmessers geliefert.

The adjustable MOTACC brake lever guard can be mounted with or without handlebar weight. It comes in black with cotters of the required handle bar inside diameter.



Bremsschutzbügel **Brake lever guard**

Art.-Nr. art. no.	Zusatz addition
75-1101208	Verstellbar inkl. Lenkerklemmung Ø 12mm adjustable, incl. Cotters
75-1101408	Verstellbar inkl. Lenkerklemmung Ø 14mm adjustable, incl. Cotters
75-1101608	Verstellbar inkl. Lenkerklemmung Ø 16mm adjustable, incl. Cotters
75-1101708	Verstellbar inkl. Lenkerklemmung Ø 17mm adjustable, incl. Cotters
75-1101808	Verstellbar inkl. Lenkerklemmung Ø 18mm adjustable, incl. Cotters
75-1102108	Verstellbar inkl. Lenkerklemmung Ø 21mm adjustable, incl. Cotters



Lenkergewichte siehe
Handlebar weights see
Seite / page 25



Superbike Spiegel Superbike mirrors

Die MOTACC Superbike Lenkerenden-Spiegel werden mit einem hochwertigen konvexen Spiegelglas gefertigt und bieten eine brillante Sicht. Die kurzen Spiegelarme minimieren Vibrationen. Die Positionierung am Ende des Lenkers ermöglicht ein optimales Blickfeld mit sicherem Blick. Die Superbike Spiegel können an Lenkern angebaut werden, an denen Lenkergewichte montiert werden können. Zwei Größen sind erhältlich: e4 (eye4) 69cm² und e3 (eye3) 50cm² Spiegelglasfläche. e4 wird beidseitig am Lenker montiert. Die Spiegel können mit kurzem oder langem, klappbarem oder geradem Spiegelarm bestellt werden. Die Spiegelgehäuse mit Glas sind einzeln erhältlich. In der Version mit dem kurzen, geraden Spiegelarm sind verschiedene Arm-Farben möglich. Standard ist der Spiegelarm schwarz wie das Spiegelgehäuse.

MOTACC superbike mirrors for handlebar ends are made with a high-quality convex mirror glass and offer a brilliant vision. The short mirror arms minimize vibrations. The position at the end of the handlebar offers an ideal and safe view. Installable on every handlebar that permits the installation of handlebar weights.

Two sizes are available: e4 (eye4) 69cm² and e3 (eye3) 50cm² mirror surface. e4 is mounted on both handlebar ends. There is a choice of a short or long and of a folding or straight mirror holder. The single mirror cases with glasses are available too. With the short straight holder different arm colors are available. The rest come with a black holder – same as the mirror case.

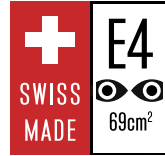

E4
Klappbar kurz
Foldable short
20-86508



E4
20-80400



E4
Gerade kurz
Straight short
20-60808

Spiegel / mirror E4

Art.-Nr. art. no.	Arm-Typ holder type	Arm-Länge holder length	Arm-Farbe holder colour
20-804yy	Gerade, kurz straight, short	75mm	yy
20-60808	Gerade, lang straight, long	85mm	Schwarz black
20-85508	Verstellbar, kurz adjustable, short	40mm	Schwarz black
20-86508	Verstellbar, lang adjustable, long	60mm	Schwarz black



E3
Klappbar kurz
Foldable short
20-82508

Spiegel / mirror E3

Art.-Nr. art. no.	Arm-Typ holder type	Arm-Länge holder length	Arm-Farbe holder colour
20-805yy	Gerade, kurz straight, short	75mm	yy
20-80708	Gerade, lang straight, long	85mm	Schwarz black
20-82508	Verstellbar, kurz adjustable, short	40mm	Schwarz black
20-83508	Verstellbar, lang adjustable, long	60mm	Schwarz black

Bestelleinheit: 1 Spiegel mit Stange montiert

Sales unit: 1 mirror with mounted holder

01 silber silver	03 blau blue	04 rot red	05 gruen green	08 schwarz black	09 gold gold	10 violett violet



E3
Gerade kurz
Straight short
20-80508



E3
20-80500



Spiegel-Kits für Lenkerenden

Mirror kits for handlebar ends



MOTACC Spiegel-Kits enthalten Lenkergewichte und die aufgeschraubten Spiegel in zwei Typen: entweder e3 (eye3) 50cm² oder e4 (eye4) 69cm² Spiegelglasfläche. e4 wird beidseitig am Lenker montiert.

Die Lenkergewichte sind in den Farben Silber, Schwarz, Gold und Anthrazit erhältlich.

Kit **M-Fit A** besteht aus zwei schraubbaren Lenkergewichten und e3 (ein Spiegel) oder e4 (zwei Spiegel) auf geraden Spiegelarmen. Die M8-Schrauben sind im Kit enthalten.

Kit **M-Fit B** besteht aus zwei Klemm-Lenkergewichten und e3 (ein Spiegel) oder e4 (zwei Spiegel) mit geradem Spiegelarm. Die Klemmungen sind im Kit nicht enthalten und werden zusätzlich bestellt (Mit der Bestellung bitte den Lenker-Innendurchmesser angeben siehe Seite 26).

Kit **Africa Twin** besteht aus zwei e4-Spiegeln auf schraubbaren Lenkergewichten für den Originallenker.

MOTACC mirror kits for handlebars contain handlebar weights and screwed on mirrors in two types: either e3 (eye3) 50cm² or e4 (eye4) 69cm² mirror surface. e4 is mounted on both bar ends. The weights come in color silver, black, gold or anthracite.

Kit **M-Fit A** contains two screw on handlebar weights and either e3 (one mirror) or e4 (two mirrors) on straight holders. The screws M8 are included.

Kit **M-Fit B** contains two handlebar weights and either e3 (one mirror) or e4 (two mirrors) with straight holders. The cotters are not included in the set and are ordered in addition. (Please indicate the bar end inside diameter for cotters, see page 26)

Kit **Africa Twin** includes two e4 mirrors on screw on handlebar weights for the original bar.



M-Fit A
mit M8 Schraube
with M8 screw



75-170800yy*



75-171800yy*

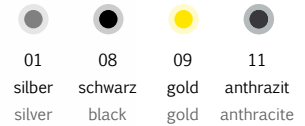

M-Fit B
ohne Klemmung
without cotters



75-164600yy*





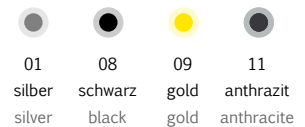

75-167600yy*





Africa Twin
75-1915yy*

- | | | | |
|---|---|---|---|
|  |  |  |  |
| 01
silber
silver | 08
schwarz
black | 09
gold
gold | 11
anthrazit
anthracite |



Lenkergewicht Typ MK1 in Verbindung
mit Spiegel „Moto11“
Handlebar weight type MK1 applied
with mirror „Moto11“



Bremsflüssigkeitsbehälter

Brake fluid reservoirs

15ccm

Edle CNC gefräste Bremsflüssigkeitsbehälter aus hauseigener Produktion. Wir bieten Behälter mit 15 und 25ccm Inhalt, die den hohen Qualitätsstandards von MOTACC Produkten entsprechen, mit verschiedenen Deckelvarianten an. Das vielfältige Zubehör gewährt einen universellen Einsatzbereich.

High-quality brake fluid reservoirs for universal use. Available in sizes 15 and 25ccm and with many different MOTACC accessories.

Bremsflüssigkeitsbehälter Komplett Sets 15ccm

brake fluide reservoirs sets 15ccm

Art.-Nr. art. no.	Nutzung use	Anschluss connection	Ø Leitung Ø Hose
69-1151098-yy	UNIVERSAL	90°	Ø8.0mm
69-1151096-yy	UNIVERSAL	90°	Ø6.5mm
69-1151008-yy	UNIVERSAL	gerade / straight	Ø8.0mm
69-1151006-yy	UNIVERSAL	gerade / straight	Ø6.5mm
69-11511011-yy	NISSIN	Adapter Nissin z.b. / e.g. CB1000R, Z1000/10	

Kupplungsflüssigkeitsbehälter Komplett Sets 15ccm

clutch fluid reservoirs sets 15ccm

69-11511011-yy	NISSIN	Adapter Nissin z.b. / e.g. CB1000R, Z1000/10
----------------	--------	--

Set erhältlich mit drei verschiedenen Deckeln Typen
(bitte yy in der Art.-Nr. durch den Deckel Sorte ersetzen):

Sets available with three type of caps
(replace yy in art. no. with cap type code):



18

Schwarz-silber gefräst
Black-silver milled



88

Schwarz-schwarz gefräst
Black-black milled



08

Schwarz nicht gefräst
Black not milled



Unsere Bremsflüssigkeitsbehälter Standardkits setzen sich aus folgenden Einzelteilen zusammen:

Our standard brake fluid reservoir kit contains the following components:

- 1: Deckel
cap
- 2: Membrane
membrane
- 3: Stützring Alu
alu support ring
- 4: Bremsflüssigkeitsbehälter
brake fluid reservoir
- 5: Halterung INOX
mount INOX
- 6: Verschiedenen Anschlüsse
(bzw. Adapter)
different connections
(altern. adapters)

Einzelteile 15ccm single parts 15ccm

Art.-Nr. art. no.	Bezeichnung description	Details details	
69-431151-08	Bremsflüssigkeitsbehälter brake fluid reservoir	schwarz black	
69-432151-18	Deckel cap	Schwarz-silber gefräst Black-silver milled	
69-432151-88	Deckel cap	Schwarz-schwarz gefräst Black-black milled	
69-432151-08	Deckel cap	Schwarz nicht gefräst Black not milled	
69-441151	Membrane membranes		
69-436253403	Stützring Alu alu support ring	25x34xh3	silber silver
69-4121501-30	Halterung mount	INOX	
69-43598-08	Zufuhrstück Ringanschluss mit Nippel feeding piece ring connector with nipple	90° ø 8.0	schwarz black
69-4111019-30	Hohlschraube banjo bolt	M10x1.00 Länge / length 19	INOX
69-43596-08	Zufuhrstück Ringanschluss mit Nippel feeding piece ring connector with nipple	90° ø 6.5	schwarz black
69-4110814-30	Hohlschraube banjo bolt	M8x1.00 Länge / length 14	INOX
69-41508-30	Zufuhrstück Schraubanschluss mit Nippel feeding piece screwed connection with nipple	gerade / straight ø 8.0	INOX
69-41506-30	Zufuhrstück Schraubanschluss mit Nippel feeding piece screwed connection with nipple	gerade / straight ø 6.5	INOX
69-434901-08	Adapter Nissin Typ 01	schwarz black	
15-136008	Bremsflüssigkeitsschlauch Typ 136 brake fluid tube type 136	I ø 07 A ø 12	schwarz black



Bremsflüssigkeitsschlauch Typ 136
brake fluid tube type 136

6



Zufuhrstück Schraubanschluss mit Nippel
feeding piece screwed connection with nipple
gerade / straight
ø 8.0



Zufuhrstück Schraubanschluss mit Nippel
feeding piece screwed connection with nipple
gerade / straight
ø 6.



Adapter Nissin



Zufuhrstück Ringanschluss mit Nippel
feeding piece ring connection with nipple
90° ø 8.0
&
Hohlschraube
banjo bolt
M10x1.00, Länge / length 19



Zufuhrstück Ringanschluss mit Nippel
feeding piece ring connection with nipple
90° ø 6.5
&
Hohlschraube
banjo bolt
M8x1.00, Länge / length 14



Bremsflüssigkeitsbehälter

Brake fluid reservoirs

25ccm

Edle CNC gefräste Bremsflüssigkeitsbehälter aus hausgener Produktion. Wir bieten Behälter mit 15 und 25ccm Inhalt, die den hohen Qualitätsstandards von MOTACC Produkten entsprechen, mit verschiedenen Deckelvarianten an. Das vielfältige Zubehör gewährt einen universellen Einsatzbereich.

High-quality brake fluid reservoirs for universal use. Available in sizes 15 and 25ccm and with many different MOTACC accessories.

Bremsflüssigkeitsbehälter Komplett Sets 25ccm

brake fluid reservoirs sets 25ccm

Art.-Nr. art. no.	Nutzung use	Anschluss connection	Ø Leitung Ø Hose
69-1251098-yy	UNIVERSAL	90°	Ø8.0mm
69-1251096-yy	UNIVERSAL	90°	Ø6.5mm
69-1251008-yy	UNIVERSAL	gerade / straight	Ø8.0mm
69-1251006-yy	UNIVERSAL	gerade / straight	Ø6.5mm
69-12512012-yy	NISSIN	Adapter Nissin z.b. / e.g. Z1000/10	
69-12511012-yy	HONDA	Adapter Honda z.b. / e.g. HONDA CB1000R	

Kupplungsflüssigkeitsbehälter Komplett Sets 25ccm

clutch fluid reservoirs sets 25ccm

69-12512012-yy	NISSIN	Adapter Nissin z.b. / e.g. CB1000R, Z1000/10
----------------	--------	--

Set erhältlich mit drei verschiedenen Deckeln Typen
(bitte yy in der Art.-Nr. durch den Deckel Sorte ersetzen):

Sets available with three type of caps
(replace yy in art. no. with cap type code):



18

Schwarz-silber gefräst
Black-silver milled



88

Schwarz-schwarz gefräst
Black-black milled



08

Schwarz nicht gefräst
Black not milled



Unsere Bremsflüssigkeitsbehälter Standardkits setzen sich aus folgenden Einzelteilen zusammen:

Our standard brake fluid reservoir kit contains the following components:

- 1: Deckel
cap
- 2: Membrane
membrane
- 3: Stützring Alu
alu support ring
- 4: Bremsflüssigkeitsbehälter
brake fluid reservoir
- 5: Halterung INOX
mount INOX
- 6: Verschiedenen Anschlüsse
(bzw. Adapter)
different connections
(altern. adapters)

Einzelteile 25ccm single parts 25ccm

Art.-Nr. art. no.	Bezeichnung description	Details details	
69-431251-08	Bremsflüssigkeitsbehälter brake fluid reservoir		schwarz black
69-432251-18	Deckel cap		Schwarz-silber gefräst Black-silver milled
69-432251-88	Deckel cap		Schwarz-schwarz gefräst Black-black milled
69-432251-08	Deckel cap		Schwarz nicht gefräst Black not milled
69-441251	Membrane membranes		
69-436354001	Stützring Alu alu support ring	35x40x1	silber silver
69-4122501-30	Halterung mount		INOX
69-43598-08	Zufuhrstück Ringanschluss mit Nippel feeding piece ring connector with nipple	90° ø 8.0	schwarz black
69-4111019-30	Hohlschraube banjo bolt	M10x1.00 Länge / length 19	INOX
69-43596-08	Zufuhrstück Ringanschluss mit Nippel feeding piece ring connector with nipple	90° ø 6.5	schwarz black
69-4110814-30	Hohlschraube banjo bolt	M8x1.00 Länge / length 14	INOX
69-41508-30	Zufuhrstück Schraubanschluss mit Nippel feeding piece screwed connection with nipple	gerade / straight ø 8.0	INOX
69-41506-30	Zufuhrstück Schraubanschluss mit Nippel feeding piece screwed connection with nipple	gerade / straight ø 6.5	INOX
69-434901-08	Adapter Nissin Typ 01		schwarz black
69-4341012-08	Adapter Honda z.b. / e.g. CB1000R		schwarz black
15-136008	Bremsflüssigkeitsschlauch Typ 136 brake fluid tube type 136	I ø 07 A ø 12	schwarz black



Bilder der Anschlüsse / Adapter see
Picture of connections / adapters see
Seite / page 29



Adapter Honda



Blinker und Blinkerhalter Indicator and indicator holder

Die MOTACC Blinkerhalter kommen zum Einsatz, wenn die Originalspiegel Blinker enthalten und ersetzt werden: Zubehör-Blinker werden mit den Blinkerhaltern montiert. Je nach Motorradmodell werden gerade oder gekröpfte Blinkerhalter verwendet.
Diverse Zubehör-Blinker stehen zur Verfügung.

Use MOTACC indicator holders, if original mirrors which include indicators are replaced. The aftermarket indicators get mounted with indicators. According to the bike model, straight or cranked indicator holders are used. There is a choice of various after market indicators.

Spezierschraube
für Kabeldurchführung
Special screw
for cable feedthrough
M8x45mm l Ø 5mm
30-1912058045

Blinkerhalter Gerade
Indicator holder straight
66-200008

Blinkerhalter Gekröpft
Indicator holder bent
66-200208

Universal Blinkerhalter schwarz Universal Indicator holder black

Art.-Nr. art. no.	ME qu	Typ type	Zusatz add.
66-200008	Paar pair	000	für diverse Modelle (gerade) for various models (straight)
66-200208	Paar pair	002	für diverse Modelle (gekröpft) for various models (bent)



Blinker / Indicator

Art.-Nr. art. no.	ME qu	A	B	C	D
66-203065	Paar / pair		44,5mm	36mm	18,5mm
66-203027	Paar / pair	70mm	82mm	20mm	23mm
66-204006	Paar / pair	25mm	36mm	11mm	13mm
66-203890	Paar / pair	46mm	66mm	27mm	27mm
66-203892	Paar / pair	46mm	86mm	27mm	27mm

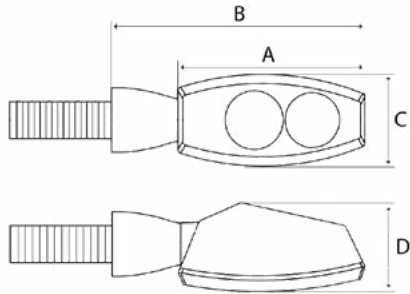

Superbike Spiegel siehe
Superbide mirrors see
Seiten / pages 27-28



66-203065



LAUFLICHT! MOVING LIGHT!
66-203027



Kurz / short
66-203890
Lange / long
66-203892



66-204006



Nummernschildbeleuchtung License plate light

Die Nummernschildbeleuchtung ist universell für die Montage an originalen Nummernschildhalterungen. Sie ist aus Aluminium in CNC gefräst, schwarz eloxiert und wird für die Befestigung mit zwei M6-Schrauben geliefert. Die LED sind austauschbar.

The license plate light can be mounted to the original plate holder. It comes in CNC machined aluminium, black anodized and with two screws M6 for mounting. LEDs are replaceable.



66-256038



Blinkerabdeckungen Indicator covers

Für die Montage von Zubehör-Blinkern empfehlen wir die formschönen MOTACC Blinkeradapter aus Aluminium.

Die Blinker werden direkt auf die Adapter montiert. Die Adapter werden als Paar in Schwarz gemäss der folgenden Verwendungsliste geliefert. Fragen Sie uns für nicht aufgeführte Artikel an.

For after market indicators use the well-designed MOTACC indicator adapters in aluminium. The indicators get mounted directly on the adapters. They come in pairs in color black according to the following application list. Ask us for articles which are not found on the list.

Modell model	Typ type	Bj. year
Suzuki	Art.Nr./art.no.:	SU001
SV 650 S	BY1321	2006
GSF 650 SA Bandit	B51131	2006
GSF 650 SA Bandit	B51131	2005
DR-Z 400 SM	BC1112	2005
GSF 1200 S Bandit	A91111	2001
GSF 1200 SA Bandit ABS	CB1131 K6	2006
GSF 600 S Bandit	A81111	2000
GSF 600 S Bandit	A81111	2004
GSF 650 Bandit	B51121	2005
GSF 650 A Bandit ABS	CJ1241	2007
GSF 650 S Bandit	B51111	2005
SV 650 S	BY1321	2007
GSF 650 A Bandit ABS	CZ1241	2009
SV 1000 S	BX1111	2004
SV 1000 S	BX1111	2003
GSX-R 1000	BL1112	2001
GSX-R 1000	BZ1111	2003
GSX-R 1000	BZ1111	2004
GSX-R 1000	B61111	2005
GSX-R 750	B31111	2004
GSX-R 600	BG1112	2001
GSX-R 600	B21111	2004
GSX-R 750	BD1112	2002
SV 650 S	BY1321	2003
GSF 650 SA Bandit	CJ1131	2007
GSF 650 SA Bandit	CZ1121	2009
GSF 650 SA Bandit	CZ1121	2015
GSF 650 SA Bandit	CZ1121	2014
GSF 650 SA Bandit	CZ1121	2013
GSF 650 SA Bandit	CZ1121	2012
GSF 650 SA Bandit	CZ1121	2011
GSF 650 SA Bandit	CZ2121	2016
SV 650 SA ABS	BY1341	2008

Modell model	Typ type	Bj. year
Suzuki	Art.Nr./art.no.:	SU001
SV 650 S	BY1321	2006
GSF 650 SA Bandit	B51131	2006
GSF 650 SA Bandit	B51131	2005
DR-Z 400 SM	BC1112	2005
GSF 1200 S Bandit	A91111	2001
GSF 1200 SA Bandit ABS	CB1131 K6	2006
GSF 600 S Bandit	A81111	2000
GSF 600 S Bandit	A81111	2004
GSF 650 Bandit	B51121	2005
GSF 650 A Bandit ABS	CJ1241	2007
GSF 650 S Bandit	B51111	2005
SV 650 S	BY1321	2007
GSF 650 A Bandit ABS	CZ1241	2009
SV 1000 S	BX1111	2004
SV 1000 S	BX1111	2003
GSX-R 1000	BL1112	2001
GSX-R 1000	BZ1111	2003
GSX-R 1000	BZ1111	2004
GSX-R 1000	B61111	2005
GSX-R 1300 Hay- abusa	A11112	1999
GSX-R 750	BD1112	2000
GSX-R 750	B31111	2004
GSX-R 750 SRAD	GR7DB	1998
GSX-R 600	AD3112	1999
GSX-R 600	BG1112	2001
GSX-R 600	B21111	2004
GSX-R 600 SRAD	AD3112	1998
GSX-R 750	BD1112	2002
SV 650 S	BY1321	2003
GSF 650 SA Bandit	CZ1121	2011
SV 650 SA ABS	BY1341	2008

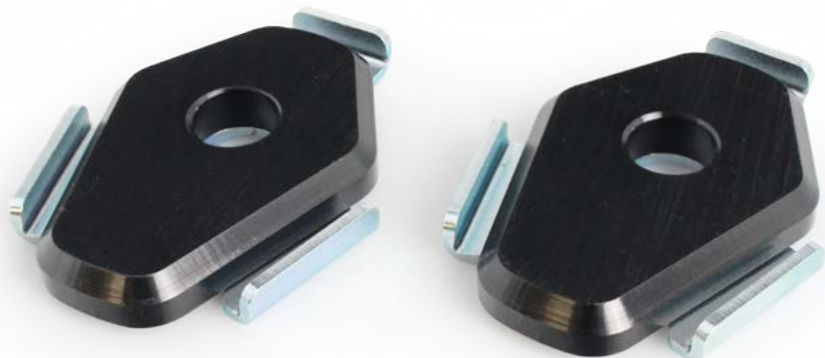

SU001



BM001

Modell model	Typ type	Bj. year
BMW*	Art.Nr./art.no.: BM001	
R nine T	K21, K22, K23, K32, K33	2014
Kawasaki	Art.Nr./art.no.: KA001	
ZX-6 R 636	ZX636C	2005
ZX-6 RR	ZX600KK	2003
ZX-6 R	ZX600G	1998
ZX-6 R	ZX600JJ	2000
ZX-6 R 636	ZX636B	2003
ZX-6 R 636	ZX636A	2002
ZX-7 R	ZX750P	1996
ZR-7	ZR750FF	1999
ZR-7	ZR750FF	2001
ZX-7 R	ZX750P	2001
ZX-9 R	ZX900EE	2000
ZX-9 R	ZX900EF	2002
ZX-6 RR	ZX600N	2005
ZX-6 RR	ZX600N	2006
ZRX 1200 S	ZRT20AB	2004
Z 750	ZR750J	2004
Z 750 ABS	ZR750L	2007
KLE 500	LE500A	1991
KLE 500	LE500A	1994
KLE 500	LE500A	1999
KLE 500	LE500A	1996
ZR-7 S	ZR750FH	2001
ZX-7 RR	ZX750N	1996
ZX-7 RR	ZX750N	1998
ZX-9 R	ZX900C	1998
Z 750 S	ZR750J	2006
Z 750 S	ZR750J	2005

Modell model	Typ type	Bj. year
Kawasaki	Art.Nr./art.no.: KA001	
ZX-6 R 636	ZX636C	2005
ZX-6 RR	ZX600KK	2003
ZX-6 R	ZX600G	1998
ZX-6 R	ZX600JJ	2000
ZX-6 R 636	ZX636B	2003
ZX-6 R 636	ZX636A	2002
ZX-7 R	ZX636C	1996
ZR-7	ZX600KK	1999
ZR-7	ZX600G	2001
ZX-7 R	ZX600JJ	2001
ZX-9 R	ZX636B	2000
ZX-9 R	ZX636A	2002
ZX-6 RR	ZX750P	2005
ZX-6 RR	ZR750FF	2006
ZX-12 R	ZR750FF	2000
ZX-12 R	ZX750P	2002
ZX-12 R	ZX900EE	2001
ZRX 1200 S	ZX900EF	2004
Z 750	ZX600N	2004
Z 750 ABS	ZX600N	2007
KLE 500	ZRT20AB	1991
KLE 500	ZR750J	1994
KLE 500	ZR750L	1999
KLE 500	LE500A	1996
ZR-7 S	LE500A	2001
ZX-7 RR	LE500A	1996
ZX-7 RR	LE500A	1998
ZX-9 R	ZR750FH	1998
Z 750 S	ZX750N	2006
Z 750 S	ZX750N	2005

*Passend für BMW-Modelle, kein Originalteil
Suitable for BMW motorbikes, no genuine part

Blinker siehe
Indicators see
Seite / page 31





HO001



YA001

Modell model	Typ type	Bj. year
Honda	Art.Nr./art.no.: HO001	
CBR 954 RR Fireblade	SC50	2002
CB 1300 F Super Four	SC54	2003
CB 1300 A Super Four ABS	SC54	2006
CB 1300 Super Four	SC54	2005
CBR 900 RR Fireblade	SC50	2002
CBR 900 RR Fireblade	SC50	2003
CBR 1100 XX	SC35	2004
CBR 1000 RR Fire- blade	SC57	2006
CBR 1000 RR Fire- blade	SC57	2004
CB 1000 R	SC60A	2011
CB 1000 R	SC60A	2012
CB 1000 R	SC60A	2010
CB 1000 R	SC60A	2009
CB 1000 R	SC60A	2008

Modell model	Typ type	Bj. year
Honda	Art.Nr./art.no.: HO001	
CBR 954 RR Fireblade	SC50	2002
CB 1300 F Super Four	SC54	2003
CBR 1100 XX	SC35	2001
CBR 1100 XX	SC35	1999
CB 1300 A Super Four ABS	SC54	2006
CB 1300 Super Four	SC54	2005
CBR 900 RR Fireblade	SC50	2002
CBR 900 RR Fireblade	SC50	2003
CBR 1100 XX	SC35	2004
VTR 1000 F Fire Storm	SC36	2001
VTR 1000 F Fire Storm	SC36	2003
VTR 1000 F Fire Storm	SC36	1997
CBR 1100 XX	SC35	1997

Modell model	Typ type	Bj. year
Yamaha	Art.Nr./art.no.: YA001	
YZF 1000 R Thunder Ace	4SV	2001
YZF 1000 R Thunder Ace	4VD/4SV	1996
FJR 1300	RP041	2001
FZS 1000 Fazer	RN064	2001
FZS 1000 Fazer	RN141	2005
FZS 600 S	RJ021	1998
YZF R1	RN01	1998
YZF R1	RN04	2001
YZF R1	RN01	1999
YZF R6	RJ032	1999
YZF 600 R Thunder Cat	4TV/4WD	1996
YZF R6	RJ037	2001
FZS 600 S	RJ025	2002

Modell model	Typ type	Bj. year
Yamaha	Art.Nr./art.no.: YA002	
FZ 6 SA Fazer	RJ076	2006
FZ 6 S Fazer	RJ141	2007
YZF R1	RN09	2002
YZF R1	RN121	2004
YZF R1	RN126	2006
YZF R1	RN191	2007
YZF R1	RN22	2009
YZF R6	RJ051	2003
YZF R6	RJ095	2005
FZ 6 N	RJ074	2004
FZ 6 S Fazer	RJ071	2004
TDM 900	RN08	2002
TDM 900	RN11	2004
TDM 900 ABS	RN18	2009
TDM 900 ABS	RN18	2010
TDM 900 ABS	RN18	2007
TDM 900 ABS	RN14	2006
FZ 6 SA Fazer	RJ076	2006
FZ 6 S Fazer	RJ141	2007
YZF R1	RN09	2002
YZF R1	RN121	2004
YZF R1	RN126	2006
YZF R1	RN191	2007
YZF R1	RN22	2009
YZF R6	RJ051	2003
YZF R6	RJ095	2005
FZ 6 N	RJ074	2004
FZ 6 S Fazer	RJ071	2004
TDM 900	RN08	2002
TDM 900	RN11	2004
TDM 900 ABS	RN18	2009
TDM 900 ABS	RN18	2010
TDM 900 ABS	RN18	2007

Modell model	Typ type	Bj. year
Yamaha	Art.Nr./art.no.: YA002	
TDM 900 ABS	RN14	2006
MT-07 ABS	RM17	2017
MT-07	RM04	2014
MT-07 ABS	RM04	2014
MT-09 Street Rally ABS	RN296	2014
MT-07	RM04	2015
XJ 6 N	RJ195	2009
XJ 6 Diversion N	RJ19	2011
MT-10 SP	RN451	2017
XJ 6 Diversion F	RJ191	2010
XJ 6 Diversion S	RJ191	2009
XJ 6 Diversion N	RJ19	2012
XJ 6 Diversion N	RJ19	2013
XJ 6 Diversion S	RJ191	2012
XJ 6 Diversion S	RJ22	2013
XJ 6 NA ABS	RJ19	2009
XJ 6 NA ABS	RJ19	2010
XJ 6 NA ABS	RJ19	2011
XJ 6 NA ABS	RJ19	2012
XJ 6 NA ABS	RJ22	2013
XJ 6 Diversion SA ABS	RJ191	2009
XJ 6 Diversion SA ABS	RJ191	2010
XJ 6 Diversion SA ABS	RJ191	2011
XJ 6 Diversion SA ABS	RJ191	2012
XJ 6 Diversion SA ABS	RJ22	2013
XJ 6 Diversion SA ABS	RJ229	2014

Modell model	Typ type	Bj. year
Yamaha	Art.Nr./art.no.: YA002	
XJ 6 NA ABS	RJ224	2014
XJ 6 NA ABS	RJ224	2015
XJ 6 Diversion SA ABS	RJ22	2015
XJ 6 Diversion F	RJ22	2014
MT-07 Moto Cage ABS	RM048	2014
MT-09 Street Rally	---	2016
MT-07 Moto Cage ABS	RM048	2015
MT-07 Moto Cage ABS	RM048	2016
MT-09 Sport Tracker	RN29S	2016
MT-09 Sport Tracker ABS	RN296	2015
MT-09 Sport Tracker ABS	RN296	2014
MT-09 Street Rally ABS	RN296	2015
MT-09	RN29	2013
MT-09	RN29	2014
MT-10	RN451	2016
MT-07 ABS	RM042	2016
MT-07 ABS	RM042	2015
MT-07 Moto Cage ABS	RM048	2017
MT-10		2017
MT-10 Tourer		2017
MT-09	RN29	2015
MT-09	RN29	2016
MT-09	RN43	2017
MT-10		2018
MT-10 SP		2018
MT-10 Tourer		2018



Spiegelabdeckungen Mirror covers



MOTACC Spiegelabdeckungen sind eine formschöne Lösung wenn die originalen Verkleidungsspiegel demontiert werden.

Die fein gefräzten Aluminium-Abdeckungen sind ein optisches Highlight und geben der Verkleidung durch die Verschraubung am Spiegelbefestigungspunkt bessere Stabilität.

Die Spiegelabdeckungen werden in schwarz mit den benötigten Befestigungsschrauben und Abdeckkappen geliefert.

Wenn die Blinker in den Spiegeln integriert waren, empfehlen wir unsere Blinkerhalter (siehe Seite 31) für die Montage von Zubehörblinkern mit den Spiegelabdeckungen

MOTACC mirror covers are an exclusive solution for demounted fairing mirror. In addition to the optical improvement of the bike, the MOTACC mirror covers also enhance the stability of the fairing. Shipped with screws and cover caps, available in black.

If you want to replace mirrors including indicators, use our indicator holders for small indicators, together with the mirror covers (see page 31).

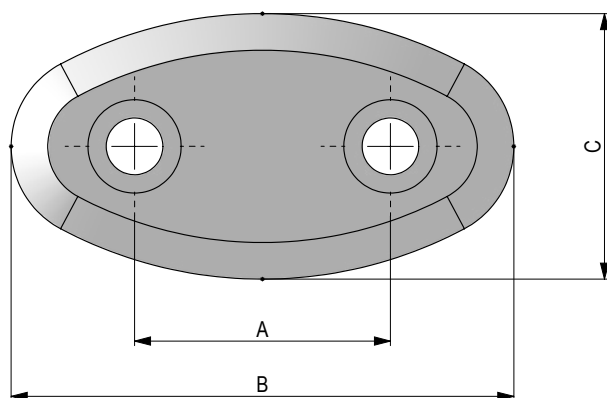

Spiegelabdeckungen / Mirror covers

Art.-Nr. art. no.	ME qu	Typ type	Zusatz add.	Lochabstand (A) hole spacing (A)	Länge (B) length (B)	Breite (C) width (C)
Aprilia						
22-2204008	Paar / pair	KA04	RS50	58mm	78mm	30mm
22-1202008	Paar / pair	HO02	RSV4	40mm	60mm	29mm
BMW *						
* Kein Originalteil, passend für BMW / Non-genuine parts, suitable for BMW						
22-4202008	Paar / pair	YA01	Passend für/suitable for S1000RR *	28mm	55mm	29mm
Buell						
22-4202008	Paar / pair	YA01	XB9R 03-, XBR12R 04-, XBR1125R	28mm	55mm	29mm
Ducati						
22-8201008	Paar / pair	DU01	alle/all Ducati Panigale 12-	36,4mm	66mm	25mm



Das Angebot wird laufend erweitert. Als Produzent können wir Ihnen auch Spezialteile und Farben liefern. Fragen Sie uns an!

We extend our product range on an ongoing basis and are - as manufacturer - able to produce customized parts and additional colours. Ask us!

Blinker und Blinkerhalter siehe indicator and indicators holders see Seite / page 31

Blinkeradapter siehe indicator adapters see Seiten / pages 32-33



Honda

22-1201008	Paar / pair	HO01	VFR750F 90-97, CBR900 RR 92-97	50mm	87mm	35mm
22-1202008	Paar / pair	HO02	CB600F/S, CBR600F/S/RR, VFR800, CBR900/1000RR, CBF1000, VTR1000SP1/SP2	40mm	60mm	29mm
22-1205008	Paar / pair	HO05	CBR1000 RR 08-	45mm	80mm	36mm
22-1206008	Paar / pair	HO06	CBR1000 RR 017-	45mm	80mm	36mm

Kawasaki

22-2201008	Paar / pair	KA01	ZX250R 08, ZX6R 95-04, Z750S 05-, ZX9R 98-03	28mm	50mm	23mm
22-2204008	Paar / pair	KA04	ZR7S 01-05, ZRX1200S 01-05	58mm	78mm	30mm
22-2205008	Paar / pair	KA05	ZX7R 97-00, ZX12R 00-06	50mm	84mm	30mm
22-2207008	Paar / pair	KA07	ZZR1400 06-	50mm	78mm	28mm
22-2208008	Paar / pair	KA08	Ninja 300 12-, ZX6R 09-12, ZX10R 11-15	46,8mm	64,5mm	24,5mm
22-2209008	Paar / pair	KA09	ZX10R 16-	47mm	72,5mm	28mm
22-1202008	Paar / pair	HO02	ER6F, ZX6R 05-08, ZX10R 04-09, Z1000SX	40mm	60mm	29mm

MV-Augusta

22-1202008	Paar / pair	HO02	F3	40mm	60mm	29mm
------------	-------------	------	----	------	------	------

Suzuki

22-3203008	Paar / pair	SU03	GSF600S 00-, GSXR 600 01-11, GSF650 S 05-, SV650S 99-, GSXR750 00-11, GSXR1000 00-08, SV1000S 03-, GSXR1300Haybusa 99-10	42mm	75mm	27mm
22-3204008	Paar / pair	SU04	GSXR1000 09-16, GSF1200S 01-	42mm	75mm	35mm
22-3205008	Paar / pair	SU05	GSXR 1000 17-	45mm	81mm	28,5mm

Yamaha

22-4201008	Paar / pair	YA01	FZS600 98-04, YZFR6 99-07, FZS1000 00-05, YZF1000R 96-04, YZFR1 98-06	28mm	55mm	29mm
22-4202008	Paar / pair	YA02	YZFR6 08-10, YZFR1 07-12	28mm	50mm	23mm
22-1202008	Paar / pair	HO02	FZ1S 06-	40mm	60mm	29mm



Hebel Levers

Brems- und Kupplungshebel aus schweizer Produktion werden von Motacc entwickelt und in einem einzigartigen Design in verschiedenen Farben hergestellt, in zwei Längen, für einen unermüdlichen Fahr-Komfort mit sechsfacher Verstellmöglichkeit.

Swiss-made brake and clutch lever developed by Motacc and manufactured in a unique design with different colors, in two lengths, for a tireless driving comfort with six different adjustment possibilities.



MOTACC®

TOURING



160mm 03 Blau / 160mm 03 blue

TOURING



160mm 11 Anthrazit / 160mm 11 anthracite

TOURING



160mm 04 Rot / 160mm 04 red



- 01 Silber / silver
- 03 Blau / blue
- 04 Rot / red

- 05 Grün / green
- 08 Schwarz / black
- 09 Gold / gold
- 11 Anthrazit / anthracite

Adapter in der Farbe Schwarz erhältlich
Hebel in verschiedenen Farben verfügbar
Adapter accessible in black
Levers available in different colors



www.motacc.com

SPORT RACING



120mm 03 Blau / 120mm 03 blue

SPORT RACING



120mm 11 Anthrazit / 120mm 11 anthracite

SPORT RACING



120mm 04 Rot / 120mm 04 red



Spezial Fertigungen ***Special adjustments***

MOTACC bietet durch hauseigene CNC Fertigung kundenspezifische Sonderanfertigungen in den verschiedenen Bereichen wie Kettenräder, Bremsscheiben, Bremsleitungen, Kupplungs- und Gaszügen an. Zusätzlich werden auf Wunsch Dreh- und Fräsarbeiten ausgeführt.

MOTACC offers through CNC manufacture custom-made products in its various areas, such as sprockets, brake discs, brake lines, clutch and throttle cables. In addition, lathe and milling work is carried out on request.



MOTACC[®]

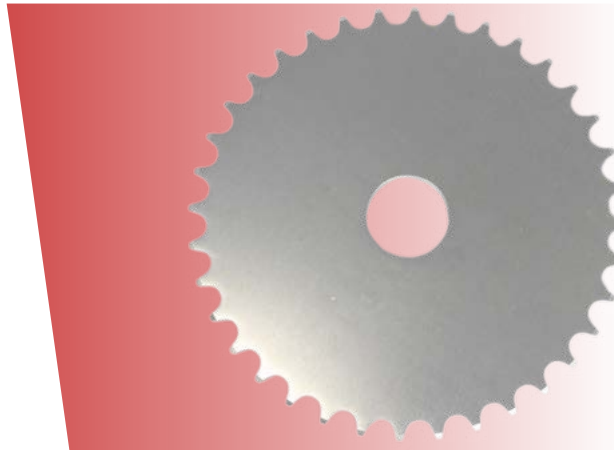

Massangefertigte Kettenräder
auf Kundenwunsch
Custom-made sprockets on
customer request

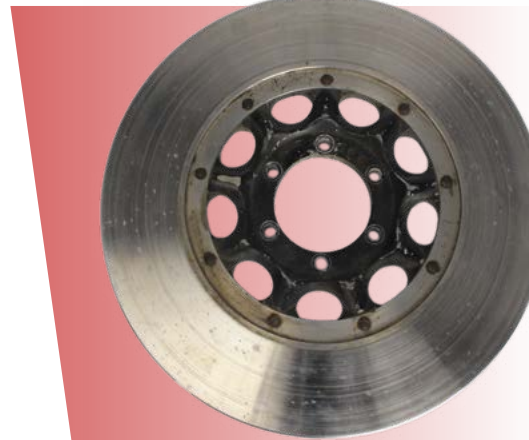

Bremsscheiben Aufbearbeitung
Brake discs reprocess

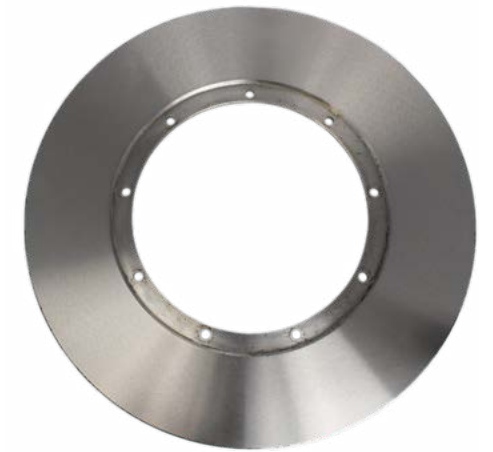



Bremsscheiben-Umbauten schwimmend
Brake disc modifications floating



www.motacc.com

STANDARD



Gas- und Kupplungszüge / throttle and clutch cables

EXTENSION



Verlängerungs-Kit / Extension kit

EASY



Innenzüge INOX / Inner cable stainless steel



Stahlflex Steel braided

Die schweizer Firma Speedbrakes produziert seit 1995 im Baselland (CH) Bremsleitungs-komponenten. Mit Produkten von höchster Qualität und schlankem Design gehören sie zu den führenden Herstellern. Die Speedbrakes Stahlflex-Bremsleitungen für Motorräder und Autos sind für alle hydraulischen Bremsanlagen in Aluminium und Edelstahl lieferbar.

The Swiss company Speedbrakes has been producing brake line components since 1995 in Baselland (CH). With products of the highest quality and slim design, they are among the leading manufacturers. Speedbrakes steel braided lines for motorcycles and cars are available for all hydraulic brake systems in aluminum and stainless steel.



Stahflexleitungen mit PTFE (Teflon®) innen Rohr
Steel braided lines with PTFE (Teflon®) inside tube



Teflon® ist eine geschützte Marke von DuPont
Teflon® is a registered trademark of DuPont

Durch die schweizer hauseigene Produktion ist Speedbrakes in der Lage individuell auf Kundenwünsche einzugehen.

Due to swiss in-house production Speedbrakes is able to meet the customer's needs individually.

Flexible Vario Schraubsystem / Vario screw system



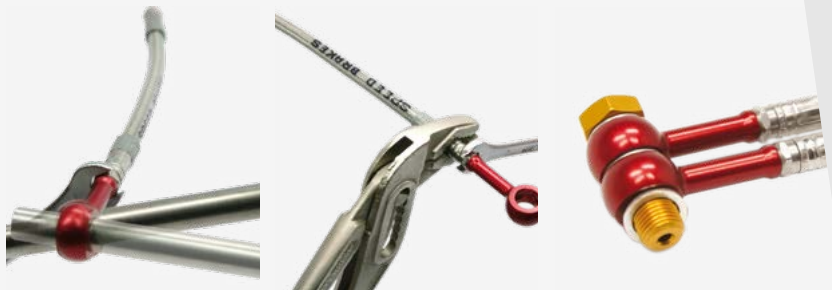

 www.motacc.com

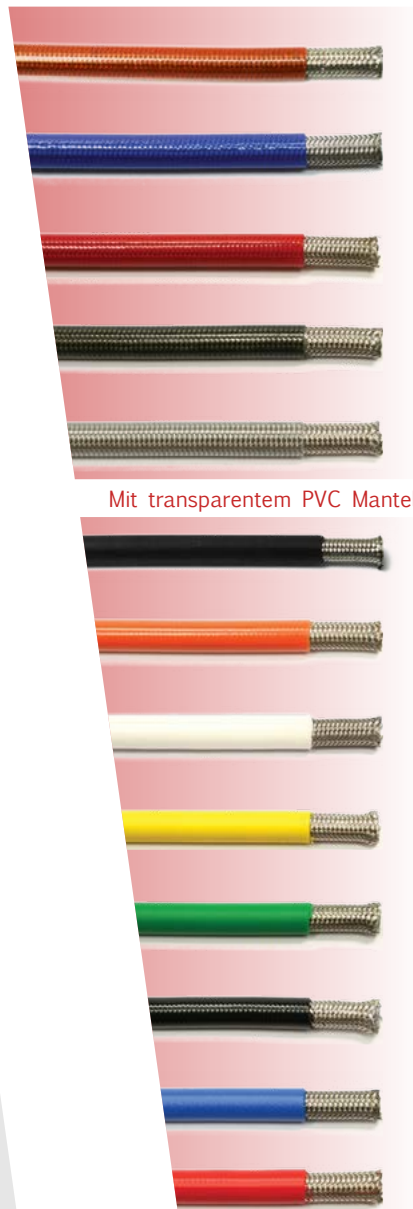

Mit transparentem PVC Mantel / With clear PVC cover

Schweizweit für ABS
Fahrzeuge
Switzerland wide for
ABS vehicles



Mit farbigem PVC Mantel / With colored PVC cover



Schnellkupplungen *Quick connectors*

Stäubli bietet ein umfangreiches Programm an Schnellkupplungen für Flüssigkeiten und Gase. Sie sind perfekt auf die Eigenschaften und Besonderheiten von Bremsflüssigkeit und Benzin ausgelegt. Herausragende Performance, Dichtheit und robuste Konstruktionen für jede Applikation.

Stäubli offers a comprehensive range of quick couplings for liquids and gases. They are perfectly designed for the requirements of brake fluid and petrol. Outstanding performance, tightness and robust constructions for every application.

STÄUBLI



B R A K E

Vario Schnellkupplung
Passend für Speedbrakes
Bremsleitungen
Vario quick connector
Suitable for Speedbrakes
brake lines

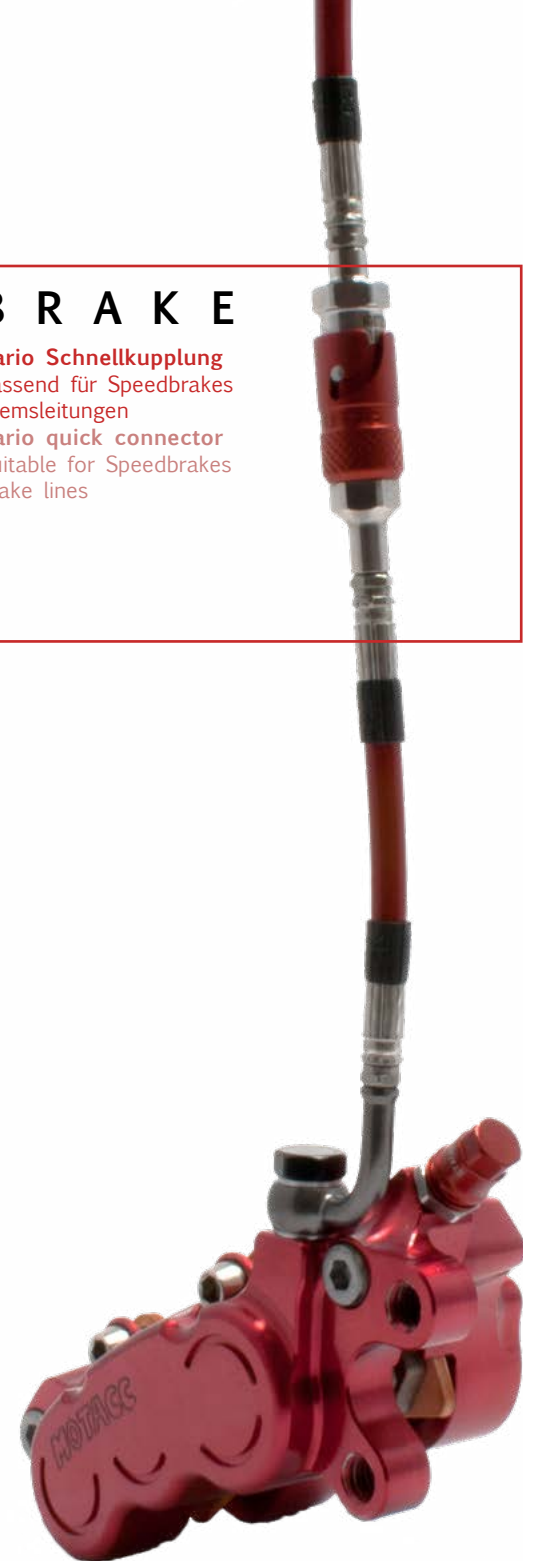



Direktanschluss zur Bremszange
Direct connection to brake caliper



www.motacc.com

LIQUID



Für Benzinleitungen / For fuel lines

BLEED



Hohlschraube+Entlüftungsnippel / Banjo bolt+bleeding nipple

POWER



Power Connector / Power connector



Anbauteile *Attachment parts*

MFW ist bereits seit 30 Jahren in der Motorradbranche verankert. Ihre Produkte „Made in Germany“ werden auf hauseigenen CNC Maschinen produziert. Ihr Produktesortiment wird international vertrieben. MFW, Speedbrakes und Motacc pflegen eine jahrzehntelange familiäre Zusammenarbeit.

MFW has been anchored in the motorcycle industry for 30 years. Their products „Made in Germany“ are produced inhouse on their own CNC machines. Their product range is sold internationally. MFW, Speedbrakes and Motacc maintain a decades-long familial collaboration.



STAND



Fussrasten / Foot rests

MOVE



Hebel / Levers

BALANCE



Bobbins + Lenkergewichte / Handlebar weights



Ein großer Artikelstamm für genausoviele Motorräder.
A large article range for as many motorcycles.

*Kein Originalteil, passend für BMW
*Non-genuine part, suitable for BMW



www.motacc.com

POSITION



Höher-, Tieferlegungen / Raising-, lowering moduls

VIEW



Spiegel / Mirrors

STEER



Vario Riser 11 Lenkererhöhung* / Handlebar riser*



Windschutzze **Windshields**

MRA ist eine der bekanntesten Marken und Hersteller von Motorrad-Windschutzscheiben, mit Vertretungen in über 50 Ländern weltweit. Hergestellt in Deutschland.

MRA is one of the best known brands and manufacturers of motorcycle windshields, with representations in more than 50 countries worldwide. Made in Germany.



ORIGINAL



Originalform

RACING



Racingform

TOURING



Tourenform



Grosse Auswahl an Windschutzschilder für jegliche Motorräder.
Large selection of windshields for any motorcycle.

*Kein Originalteil, passend für BMW
*Non-genuine part, suitable for BMW



NAKED



NRM Naked

CLASSIC



NTM Naked*

VARIO



XCSA Universal



Endtöpfe Mufflers

Bodis hat 30 Jahre Erfahrung bei der Verarbeitung von Edelstahl und Titan in unschlagbarer Qualität. Entwicklung und Konstruktion von innovativen Auspufflösungen, mit EG-Zulassung, geeignet für die Strasse und den Rennsport. Handgefertigt in Ungarn.

Bodis is having 30 years of experience in processing of stainless steel and titanium with untouchable quality. Development and construction of innovative exhaust solutions, with EG approval, suitable for the road and racing. Handmade in Hungary.

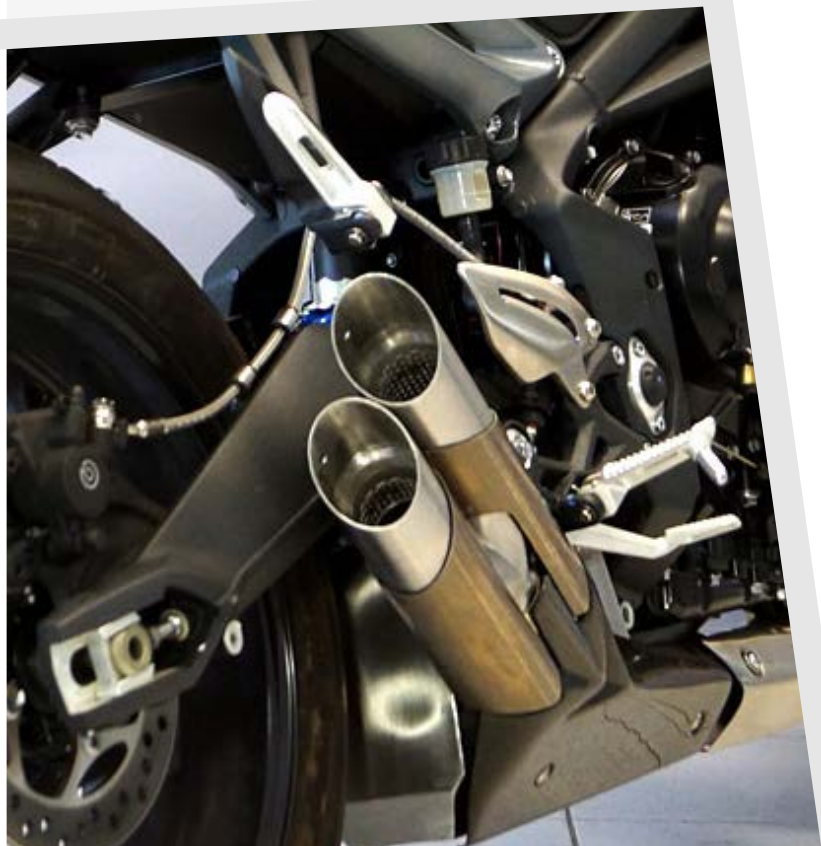

Offizieller Importeur für
die Schweiz.

Official importer for
Switzerland.



MGPX2_GE

Diverse Komplettanlagen
erhältlich auf Anfrage

Various complete systems
available on request



GPC-RS2-GE

Einfach aufsteckbare Endtöpfe

Easy slip on exhaust



MGPX2



www.motacc.com



Homologierte dB-Killer
Homologated dB-killers



GPX2



Katalysatoren
Catalysts



V-4M-CA



DUOBOLICO



Lithium Batterien ***Lithium batteries***

Aliant, ultraleichte Batterien auf Basis von Lithium-Eisen-Phosphat-Technologie.
Die Gesamtabmessungen werden um 50% und das Gewicht um bis zu 80% reduziert.

Aliant, ultra-light batteries based on lithium iron phosphate technology.
The overall dimensions are reduced by 50% and the weight up to 80%.



Hohe Startleistung
High starting-power

Mit acht Batterien ist das gesamte Motor-
radprogramm abgedeckt
With eight batteries, the entire motorcycle
program is covered

Anwenderliste / range of application

BATTERY REF	AxBxH	Volt	Ah	Li FePO4 Gewicht	CCA (-18°C)
YLP05	114x40x90	13.2	5Ah	430g	85A
YLP07	114x40x90	13.2	7Ah	450g	130A
YLP09X	114x40x90	13.2	8Ah	450g	140A
YLP10	114x69x90	13.2	10Ah	740g	200A
YLP12	114x69x90	13.2	12Ah	750g	220A
YLP14	114x69x90	13.2	14Ah	760g	245A
YLP18	148x67x133	13.2	18Ah	1600g	400A
YLP24	148x67x133	13.2	24Ah	1650g	490A
YLP30	148x67x133	13.2	30Ah	1700g	520A

Die vollständige Anwenderliste finden Sie unter www.motacc.com
The whole range of application can be found at www.motacc.com



www.motacc.com

Hohe Leistung bei tiefer Temperatur bis -18°
7-10-mal längere Lebensdauer als herkömmliche Batterien

High performance at low temperature until -18°
7-10-times longer life as conventional batteries



Aliant Ladergerät weniger als 30 Minuten Ladezeit

Aliant charger less than 30 minutes charging time



Kettenrad Lösungen ***Sprocket solutions***

JT Sprockets ist eine der weltweit führenden Kettenräder Marke für Motorräder und ATVs. Sie verwenden nur die besten Rohmaterialien und modernste Technologie in der Produktion. Ihr Sortiment bietet das ultimative Ersatzkettenrad und Ritzel zu einem unschlagbaren Preis.

JT Sprockets is one of the world's leading sprocket brand for motorcycles and ATVs. Using only the finest raw materials and using cutting edge technology in the production, their range gives the ultimate in replacement rear and front sprocket at unbeatable value.



JT
SPROCKETS



MOTACC®

Lösungen für
Kettenräder-Kits
Solutions for
sprocket kits

JT Kettenräder und Ritzel in
Originalqualität aus Japanstahl
oder Aluminium 7075-T6

JT rear and front sprockets in
original quality out of Japan
steel or aluminium 7075-T6





www.motacc.com

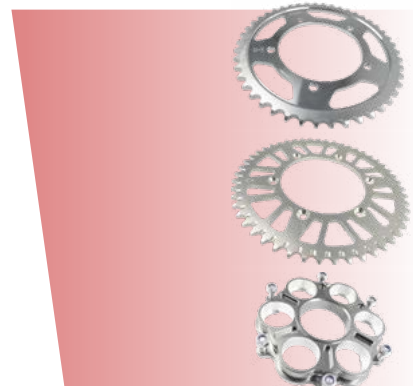

Kettenräder / Rear Sprockets

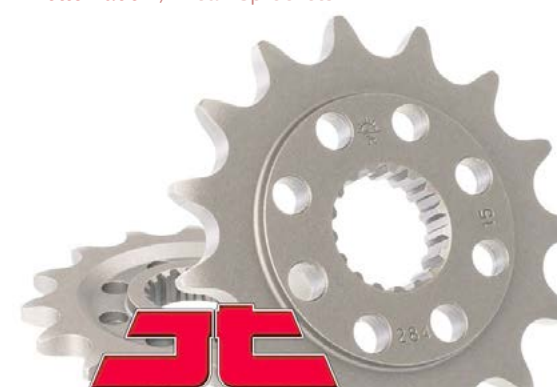
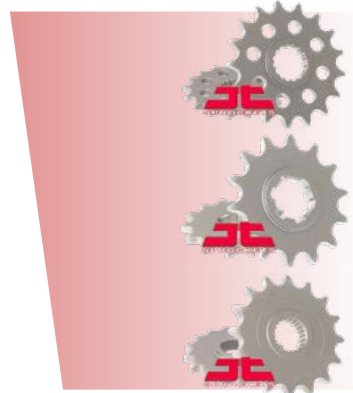

Ritzel / Front Sprockets



X-Ring Ketten / X-ring drive chains



Ketten Chains

MOTACC verkauft DC Hochleistungsketten, welche vom japanischen Hersteller EK in Erstausstattungs-Qualität produziert werden. QX-Ketten sind langlebig auch unter Extrembedingungen.

MOTACC sells DC high-performance chains, which are produced by the Japanese manufacturer EK in original equipment quality. QX chains are durable even under extreme conditions.



QX-RING



QX-Ring / QX-Ring Maxi

STANDARD



Standard- und verstärkt / Standard- and reinforced

MOTORCROSS



Profi Motocross / Professional motocross

Kettenräder Sprockets

Die Kettenräder von AFAM sind hochpräzise,
aus den besten Materialien hergestellt.

AFAM sprockets are high precision made from
the best materials.



www.motacc.com

QX-RING

*Reduzierung von Reibung
und Verschleiß*

*Reduction of friction and
wear*

*Steigerung der Flexibilität
und Leistung*

*Increase in flexibility and
performance*

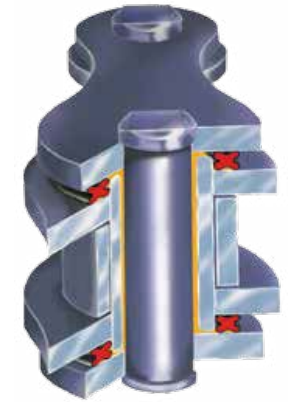

Hochwertige Kettenräder von AFAM, erhältlich bei uns.
High quality sprockets from AFAM, available from us.



Bremsscheiben ***Brake discs***

NG Brake Disc wurde 1969 in Spanien gegründet. Ihre ständige Erforschung von Materialien, Formen und Eigenschaften hat sie zu einem der namhaftesten Herstellern von Brems-scheiben gebracht. Die Motorrad Brems-scheiben von NG werden in Originalqualität für den Zubehör-Markt sowie für Erstausrüstungen eingesetzt. Dank modernen Produktionsverfahren und Spitzentechnologie wurde NG ein führender Hersteller in Europa.

NG Brake Disc was founded in 1969 in Spain. Their constant investigation in materials, shapes and features has made them one of the most reputable manufacturers of brake discs. NG motorcycle brakes are used in original quality for the aftermarket and the original equipping.



NG
Brake Disc

MODERN



735 starr / rigid

TRADITIONAL



1012 starr / rigid

WAVE



908X wave starr / wave rigid



www.motacc.com

FLOATING
W A V E

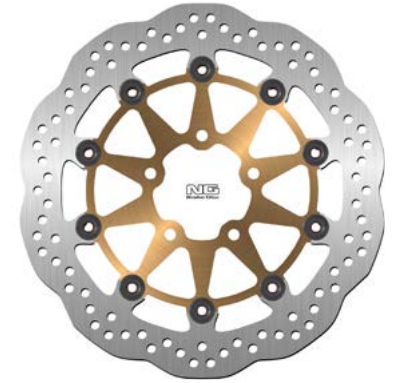

1053X wave schwimmend / wave floating

FLOATING
STANDARD

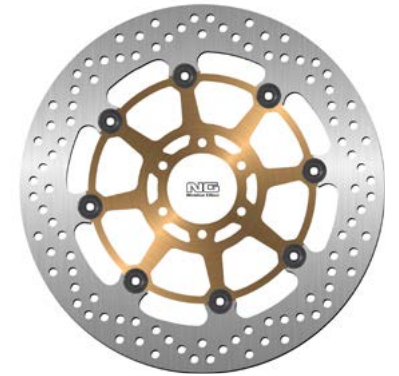

1060 schwimmend / floating

VARIO



1022 scooter



Bremsbeläge *Brake pads*

Goldfren ist in Europa ein führender Hersteller beim Anwenden der Sinterkeramik-Technologie. Goldfren Bremsbeläge werden aus einer Sinterkeramischen Metall-Graphit Mischung fabriziert. Diese Bremsbeläge haben hervorragende Eigenschaften für beste Bremskraftleistungen bei niedrigem Verschleiss.

Goldfren is a leading manufacturer of sintered ceramic technology in Europe. Goldfren brake pads are fabricated from a sintered ceramic-metal-graphite mixture. These pads have excellent attributes for best braking performance with low wear.

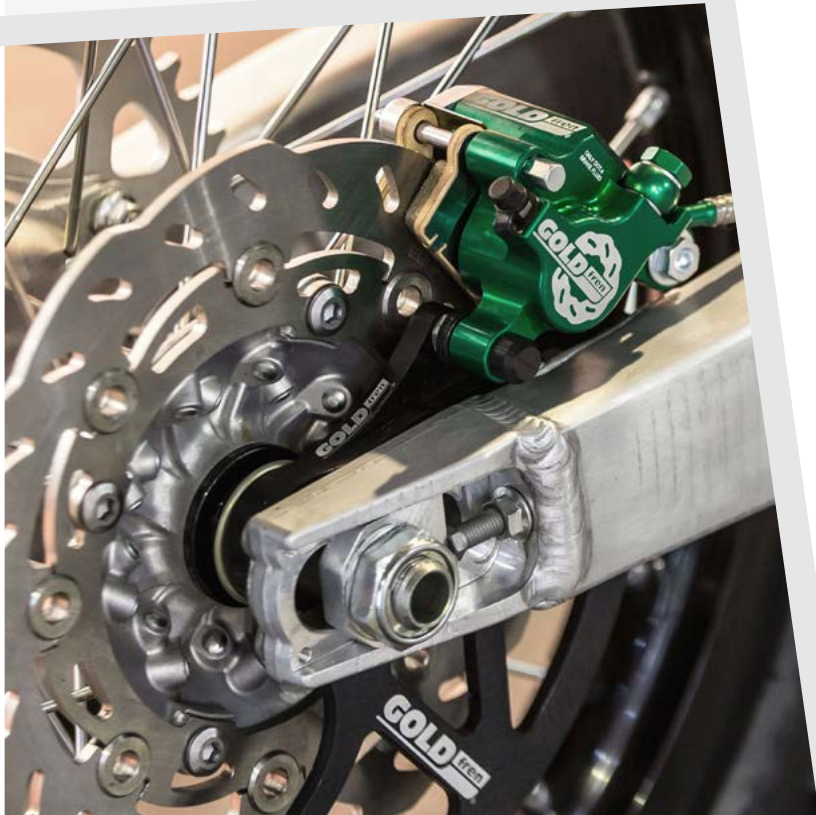

GOLDfren
DISC BRAKE PADS

STANDARD



AD

SPORT



S3

RACING



GPR

Bremsscheiben *Brake discs*

Goldfren stellt Bremsscheiben für alle weltweit bekannten Marken von Motorrädern und Scootern her. Alle Scheiben werden aus mehreren Stahllegierungen für Strassen, Offroad und Rennsport hergestellt.



Goldfren manufactures brake discs for all the world famous brands of motorcycles and scooters. All discs are made from multiple steel alloys for road, offroad and racing use.



www.motacc.com

CLASSIC



202 004 F

STREET



604 004 F

OFFROAD



7255 F



Bremskomponenten ***Brake componets***

Mit 40 Jahren Erfahrung im Rennsport bietet Brembo Racing eine umfassende Produktpalette für eine konstante Performance, hohe Bremskraft, Modularität, Kontrolle und sehr hohe Temperaturbeständigkeit.

With 40 years of racing experience, Brembo Racing offers a comprehensive range of products for consistent performance, high braking power, modularity, control and very high temperature resistance.



Bremsscheiben / Break discs



Bremszange / Break caliper



Bremspumpe / Break pump



www.motacc.com



Bremsbeläge / Break pads



Daumenbremse / Thumb break



Hauptbremszylinder / Break master cylinder



Motorradständer *Motorbike stands*

Ständer und Hebetchnik für Motorräder aus deutscher Produktion. Seit 25 Jahren fertigt KERN-STABI für den Motorradbereich Produkte in höchster Qualität.

Stand and lifting technology for motorbikes from German production. For 25 years, KERN-STABI has been producing products of the highest quality for the motorbike sector.



KERN-STABI
MOTORRADTECHNIK

FIX



Montageständer Rundrohr* / Assembly round pipe*

VARIO



Montageständer Vierkant* / Assembly stand square*

*Verschiedene Aufnahme-Typen für Motorradständer auf Anfrage erhältlich
*Various pickup types for motorcycle stands available on request



www.motacc.com

FIX



Einarmständer Profi Line* / One-arm assembly stand Profi Line*

VARIO



X4 Lenkkopfständer* / X4 caster stand*



Motoradheber *Motorbike lifters*

BF-Motorradtechnik ist ein Süddeutscher Hersteller und Vertreiber von Montageständen, Hebebühnen und Rangiersystemen für Motorräder. Ein Meisterbetrieb mit langjähriger Erfahrung der sich ausschließlich mit dem Heben und Rangieren von Motorrädern beschäftigt.

BF-Motorradtechnik is a South German manufacturer and distributor of assembly stands, lifting platforms and maneuvering systems for motorbikes. A master business with many years of experience that deals exclusively with the lifting and shunting of motorbikes.

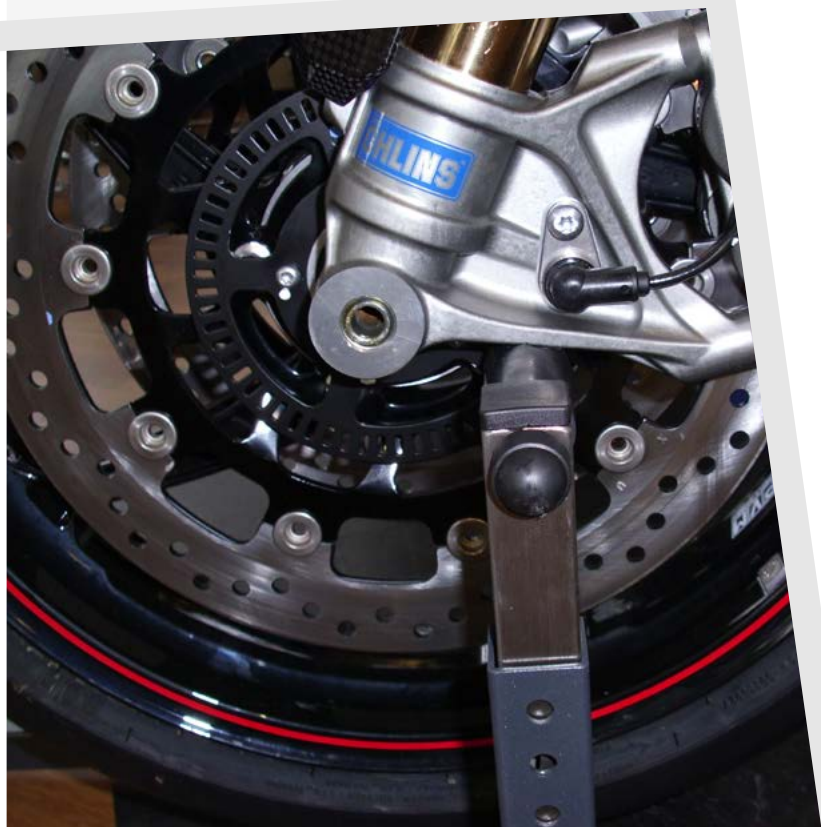

VIERKANT EXPERT



BF 107004 mit 6 Räder / with 6 wheels

VIERKANT STANDARD



BF 107004BL Bluestand



www.motacc.com

HYDRAULIC CRUISER



Hydraulischer Chopperheber / Hydraulic chopper lifter

LIFT RACING



Bluelift



Hebebühne *Lifting platform*

Die MOTACC elektrohydraulische Motorrad-Hebebühne hat eine solide Konstruktion mit einer Hubkraft von 700kg. Die Hubhöhe bis zu 1200mm bietet dem Fachhändler maximalen Arbeitskomfort. Radklemme, Antirutschplatte, Halteklammer und integrierte Auffahrtrampe sind im Grundpaket mit dabei.

The MOTACC electrohydraulic motorcycle lift has a solid construction with a lifting capacity of 700kg. The lifting height up to 1200mm offers to the expert maximum working comfort. Wheel clamp, anti-slip plate, retaining clip and integrated ramp come in the basic package.

MOTACC®

HYDRAULIC



> 700KG

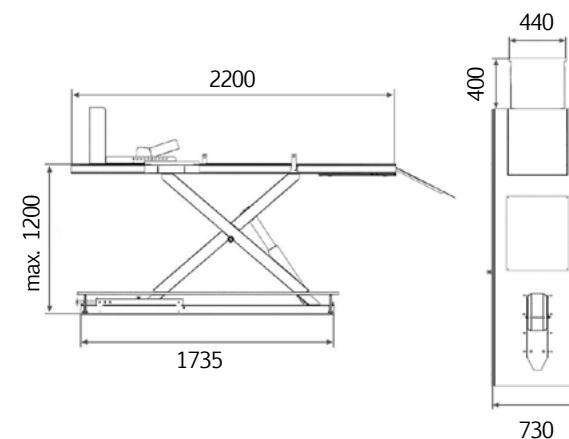

230V



Bördelwerkzeugset ***Flaring tool kit***

Mit dem hydraulischen Bördelwerkzeug von MOTACC können Stahlrohrleitungen bearbeitet werden, um diese mit Vario Stahlflexbremsleitungen von Speedbrakes zu verschrauben. Ausserdem ist das Verpressen von Seilzugnippeln mit einem Zusatzwerkzeug möglich.

The MOTACC hydraulic flaring tool kit can be used to match steel pipes with Speedbrakes Vario steel braided brake lines. In addition, the compression of cable nipples is possible by an additional tool.



www.motacc.com

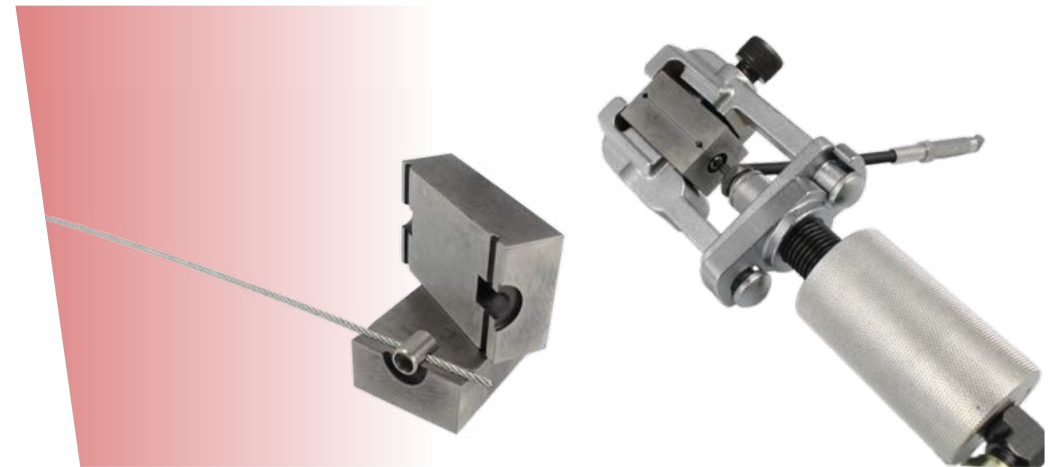

Pressbacken Seilzug / pressing jaws cable pull



Komplett-Kit/ Complete kit



Ölfilter Oil filter

HIFLOFILTRO ist der weltweit erste und einzige TÜV-zugelassene Motorradölfilter. Die HIFLOFILTRO-Ölfilter werden in OEM Qualität aus den besten Materialien hergestellt und erfüllen oder übertreffen die Leistungsmerkmale der Originalausrüstung.

HIFLOFILTRO is the world's first and only TÜV approved motorcycle oil filter. The HIFLOFILTRO oil filters are manufactured in OEM quality from the best materials and meet or exceed the features of the original equipment.



HIFLOFILTRO
PREMIUM FILTERS

STANDARD



HF138

RACING



HF204RC

CUSTOM



HF303C

Luftfilter

Air filter

HIFLOFILTRO Luftfilter werden passgenau für die Original-Luftfilterkästen in OEM Qualität fabriziert. Dadurch können diese Luftfilter als Originalersatz ohne Leistungsverlust ausgetauscht werden.

HIFLOFILTRO air filters are manufactured to fit the original air filter box in OEM quality. As a result, these air filters can replace the original filter without loss of performance.



www.motacc.com

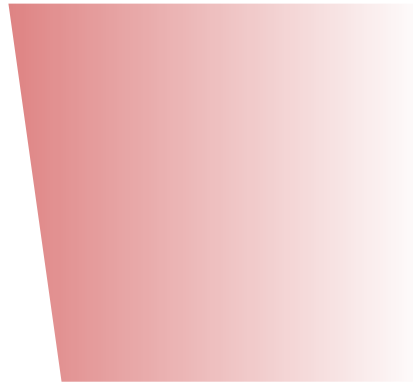

HFA1715



HFA2901



HFA4703



Motorradöle Motocycle oils



SPEC-X von MOTACC sind Motorenöle der Spitzen-Klasse und für Getriebe mit Ölbadkupplungen bestens geeignet. Wurden zusammen mit Motorradproduzenten entwickelt. Auch unter Extrem-Bedingungen ist ein leichtes Schalten gewährleistet. Die Palette reicht von mineralischem, über teilsynthetischem bis hin zu vollsynthetischem Racing-Motorradöl für 4- und 2 Takt-Motoren.

SPEC-X from MOTACC, engine oils of the top class best suited for gearboxes with oil bath clutches. Was developed together with motorcycle manufacturers. Easy shifting is guaranteed even under extreme conditions. The spectrum ranges from mineral, partly synthetic to fully synthetic racing motorcycle oil for 4- and 2-stroke engines.

MADE IN GERMANY 



60L
20L
4L
1L



BIKE 2T „STREET“

teilsynthetisch / semi-synthetic

API TC (TSC-3), JASO FC/FD, ISO-L-EGD (Low Smoke)

20L
4L
1L



BIKE 2T „RACING“

synthetisch / synthetic

API TC (TSC-3), JASO FC/FD, ISO-L-EGD (Low Smoke)

1L



BIKE 2T „CROSS“

synthetisch / synthetic

API TC (TSC-3), JASO FC/FD, ISO-L-EGD (Low Smoke)

4L
1L



SCOOTER 2T „STREET“

teilsynthetisch / semi-synthetic

API TC (TSC-3), JASO FC/FD, ISO-L-EGD (Low Smoke)

1L



SCOOTER 2T „RACING“

synthetisch / synthetic

API TC (TSC-3), JASO FC/FD, ISO-L-EGD (Low Smoke)

4L
1L



SCOOTER 4T „STREET“ 5W-40

HC-Synthese / HC synthesis

API SL, JASO MA-2

208L
60L
20L
4L
1L



BIKE 4T „STREET“ 5W-40

HC-Synthese / HC synthesis

API SL, JASO MA-2

208L
60L



BIKE 4T „STREET“ 10W-30

teilsynthetisch / semi-synthetic

API SL, JASO MA-2

208L
60L
20L
4L
1L



BIKE 4T „STREET“ 10W-40

teilsynthetisch / semi-synthetic

API SL, JASO MA-2

Bei Motacc auch erhältlich: Brems- und Kühlflüssigkeit, Gabel- und Getriebeöle sowie Bremsreiniger von Spec-X. Das Spec-X Programm wird laufend erweitert.

Also available from Motacc: brake and coolant fluid, fork and gear oils, and brake cleaner from Spec-X. The Spec-X program is constantly being expanded.



Mineralisches Öl
Mineral oil



Teilsynthetisches Öl
Semi-synthetic oil



Vollsynthetisches Öl
Full-synthetic oil



www.motacc.com



4L
1L

BIKE 4T „CROSS“ 10W-40

teilsynthetisch / semi-synthetic

API SL, JASO MA-2



208L
60L
20L

BIKE 4T „RACING“ 10W-40

synthetisch / synthetic

API SL, JASO MA-2



1L
208L
60L
20L

BIKE 4T „RACING“ 10W-50

synthetisch / synthetic

API SJ, JASO MA-2



4L
1L

BIKE 4T „RACING“ 10W-60

synthetisch / synthetic

API SJ, JASO MA-2



208L
60L
20L
4L
1L

BIKE 4T „RACING“ 15W-50

synthetisch / synthetic

API SL, JASO MA-2



20L
4L
1L

BIKE 4T „STREET“ 20W-40

mineralisch / mineral

API SG/SL, JASO MA-2



60L
20L
4L
1L

BIKE 4T „STREET“ 20W-50

mineralisch / mineral

API SG, JASO MA-2



4L

BIKE 4T „CLASSIC“ 20W-50

mineralisch / mineral

API SF/CD, JASO MA-2

STAND 2018
HÄNDLER KATALOG
PUBLISHED IN 2018
DEALER EDITION

VERTEILER DISTRIBUTOR

MOTACC SUISSE GMBH

Muttenerstrasse 119
CH-4133 Pratteln
Schweiz

Tel.: +41 (0) 61 826 96 26
Fax: +41 61 (0) 826 96 25
www.motacc.ch
info@motacc.ch

MOTACC DEUTCHLAND GMBH

Siemensstrasse 5
D-79331 Teningen-Nimburg
Deutschland

Tel.: +49 (0) 7663 9429945
Fax: +49 (0) 7663 9429946
www.motacc.de
info@motacc.de

